

GV-VMS

User's Manual V18.1





© 2020 GeoVision, Inc. All rights reserved.

Under the copyright laws, this manual may not be copied, in whole or in part, without the written consent of GeoVision.

Every effort has been made to ensure that the information in this manual is accurate. GeoVision, Inc. makes no expressed or implied warranty of any kind and assumes no responsibility for errors or omissions. No liability is assumed for incidental or consequential damages arising from the use of the information or products contained herein. Features and specifications are subject to change without notice.

Note: No memory card slot or local storage function for Argentina.

GeoVision, Inc.
9F, No. 246, Sec. 1, Neihu Rd.,
Neihu District, Taipei, Taiwan
Tel: +886-2-8797-8377
Fax: +886-2-8797-8335
<http://www.geovision.com.tw>

Trademarks used in this manual: *GeoVision*, the *GeoVision* logo and GV series products are trademarks of GeoVision, Inc. *Windows* is the registered trademark of Microsoft Corporation.

March 2020

GV-VMS Licensing

GV-VMS is a comprehensive video management system, and requires a purchased license starting from V18.1, that records up to 64 channels of GeoVision and/or third-party IP devices. Make sure your purchased *GV-Dongle* or *software license* has been inserted into or activated on the PC prior to running GV-VMS.

IMPORTANT: For users who have purchased a software license, it must be registered through the **License Activation Tool** using the corresponding serial key. For details on software licensing, click [here](#).

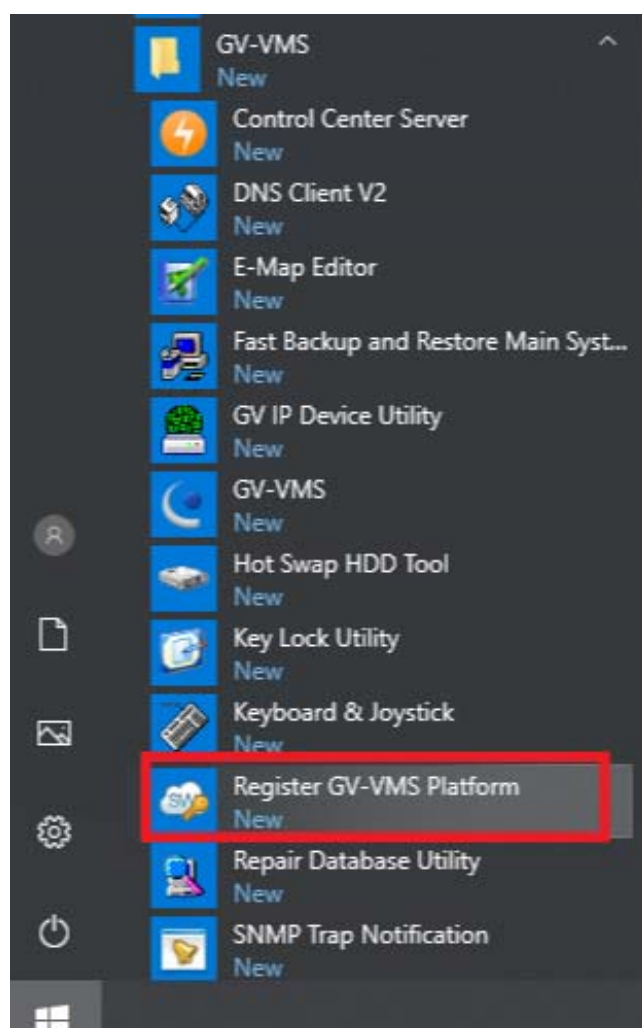

Note: For users with GV-Dongle of earlier versions of GV-VMS, it must be upgraded to run V18.1 or later. See *Chapter 8 Dongle Upgrade* in [GV-VMS Quick Start Guide](#).

Additional dongle or software license(s) will be required for connecting to third-party IP devices. See *License* in Chapter 1 for details.

GPU Decoding

GPU (Graphics Processing Unit) decoding can lower the CPU loading and increase the total frame rate supported by a GV-VMS. GPU decoding can be performed by an onboard GPU, external GPU, or both, under the following specifications.

Onboard GPU: GPU decoding is only supported when using the following Intel CPU:

For **H.264** Video Compression

- 2nd Generation Intel Core i3 / i5 / i7 Desktop Processors (Sandy Bridge)
- 3rd Generation Intel Core i3 / i5 / i7 Desktop Processors (Ivy Bridge)
- 4th Generation Intel Core i3 / i5 / i7 Desktop Processors (Haswell / Haswell Refresh)
- 6th Generation Intel Core i3 / i5 / i7 Desktop Processors (Skylake)
- 7th Generation Intel Core i3 / i5 / i7 Desktop Processors (Kaby lake)
- 8th Generation Intel Core i3 / i5 / i7 Desktop Processors (Coffee lake)
- 9th Generation Intel Core i3 / i5 / i7 Desktop Processors (Coffee lake / Coffee lake Refresh)

For **H.265** Video Compression

- 6th Generation Intel Core i3 / i5 / i7 Desktop Processors (Skylake)
- 7th Generation Intel Core i3 / i5 / i7 Desktop Processors (Kaby lake)
- 8th Generation Intel Core i3 / i5 / i7 Desktop Processors (Coffee lake)
- 9th Generation Intel Core i3 / i5 / i7 Desktop Processors (Coffee lake / Coffee lake Refresh)

External GPU: GPU decoding is only supported when using NVIDIA graphics cards with compute capability 3.0 or above and memory 2 GB or above. To look up the compute capability of the NVIDIA graphics cards, refer to: <https://developer.nvidia.com/cuda-gpus>.

Note:

1. One external NVIDIA graphics card can be supported by GV-VMS17.1 or later to perform GPU decoding at free of charge.
 2. NVIDIA GeForce GTX 1060 is not supported.
-

Onboard GPU + external GPU: To have both the onboard and external GPU to perform GPU decoding, the GPUs must follow their respective specifications listed above.

Note:

1. If you have both onboard external GPU installed, the onboard GPU must be connected to a monitor for H.264 / H.265 GPU decoding.
 2. CUDA compute capability 5.0 or higher is required to ensure optimal performance. For more information, see [Total frame rate and number of channels supported](#)
-

Software Specifications

GPU decoding is only supported under the following operating system, resolution, and codec.

		Sandy Bridge	Ivy Bridge / Haswell / Haswell Refresh / Skylake	Skylake	Kaby Lake / Coffee Lake
Operating System	64-Bit	Windows 10 / Server 2008 R2 / Server 2012 R2			Windows 10
Resolution		1 MP / 2 MP	1 MP / 2 MP / 3 MP / 4 MP / 5 MP / 8 MP / 12 MP	1 MP / 2 MP / 3 MP / 4 MP / 5 MP	
Codec		H.264			H.264 / H.265

Multi-Channel Playback

Multi-channel playback in ViewLog has been enhanced to improve the smoothness of the video by producing higher frame rate. However, playing back multiple channels at high resolution can increase the CPU loading especially if the GV-VMS is processing other tasks simultaneously. As a result of the high CPU loading, dropped frames may sometimes occur in recorded video when playing back multiple megapixel channels. To avoid the problem, **it is recommended to play back megapixel video in single view.**

GDPR Practice

For details on how GeoVision Inc. is committed to helping users become GDPR (General Data Protection Regulation) compliant, visit the [GDPR Consent Request](#).

Contents

GV-VMS Licensing.....	i
GPU Decoding.....	ii
Multi-Channel Playback.....	iii
GPDR Practice.....	iii

1

Configuring Main System 3

1.1 Installing GV-VMS.....	3
1.1.1 License.....	3
1.1.2 Minimum System Requirements.....	4
1.1.3 Options.....	5
1.1.4 Minimum Network Requirements.....	6
1.1.5 Installing GV-VMS.....	7
1.2 Getting Started.....	8
1.2.1 Main Screen.....	9
1.2.2 Adding Cameras.....	10
1.2.3 Accessing Live View.....	11
1.2.4 Enabling Recording.....	11
1.2.5 Playing Back Video.....	12
1.3 Recording Settings.....	13
1.3.1 Setting Global Recording Settings for All Cameras.....	14
1.3.2 Setting Recording Settings for Individual Cameras.....	16
1.3.3 Setting Up Video Storage Location.....	18
1.3.4 Setting Up Motion Detection.....	19
1.4 Live View and Layouts.....	22
1.4.1 Utilizing Live View Functions.....	22
1.4.2 Arranging Live View Layouts.....	24

1.4.3	Setting a Zoom Window	25
1.4.4	Setting a Scan Window	25
1.4.5	Setting a Popup Window	27
1.4.6	Setting Focus View.....	28
1.4.7	Automatic Switch among Different Live View Layouts	29
1.4.8	Adding GV-IP Decoder Box for Remote Monitor Display.....	29
1.5	Starting Monitoring.....	30
1.6	System Configuration	31
1.6.1	Configuring General Settings	31
1.6.2	Customizing Startup Settings.....	33
1.6.3	Customizing Display Position and Panel Resolution	34
1.6.4	Setting up E-mail Notification	35
1.6.5	System Idle Protection	37
1.6.6	Configuring Fast Key Lock	38
1.7	Account and Password.....	38
1.7.1	Creating an Account.....	38
1.7.2	Configuring Account Settings.....	39
1.7.3	Changing or Retrieving Password at Login.....	41
1.7.4	Preventing Unauthorized System Termination.....	41
1.7.5	Setting a Startup Auto Login User.....	42
1.7.6	Setting Limits on Playback Time	42
1.8	Schedule.....	43
1.8.1	Creating a Schedule with Setup Wizard.....	44
1.8.2	Creating a Schedule Manually	46
1.8.3	Exporting and Importing Schedule Settings.....	47
1.9	System Log	47
1.9.1	Setting System Log	47
1.9.2	Viewing System Log.....	49
1.10	Other Functions	51
1.10.1	Setting Pop-up Live View	51
1.10.2	Adjusting to Daylight Saving Time	52
1.10.3	Setting Network Failure Detection.....	53
1.11	PTZ Camera	54
1.11.1	Accessing PTZ Control Panel and Auto Functions	55
1.11.2	Setting PTZ Idle Protection and Advanced Functions	57
1.12	QView	58
1.13	Storyline	59
1.13.1	Creating a Storyline in Live View	59

1.13.2	Creating a Storyline in Video Playback	60
1.13.3	Creating a Storyline in QView	60
1.13.4	Accessing the Storyline	61
1.14	GV-VR360 Dewarped View	61

2 IP Camera Setup64

2.1	Adding IP Cameras	64
2.1.1	Adding Cameras Manually	65
2.1.2	Scanning for Cameras.....	67
2.1.3	Mapping GV-IP Cameras using GV-IP Device Utility.....	67
2.1.4	Adding Cameras of Mobile Devices with GV-Live Streaming	68
2.2	Configuring Individual IP Cameras	68
2.2.1	Configuring Video Settings.....	69
2.2.2	Configuring Audio Settings.....	71
2.2.3	Configuring General Settings	72
2.3	Connection through RTSP, ONVIF & PSIA	73
2.4	On Demand Display.....	76

3 Video Analysis80

3.1	Object Counting and Intrusion Alarm.....	80
3.1.1	Objecting Counting.....	80
3.1.2	Intrusion Alarm	83
3.2	Object Index	86
3.2.1	Setting Object Index	86
3.2.2	Viewing Object Index.....	88
3.2.3	Searching Object Index	89
3.3	Automatic Video Snapshots	90
3.3.1	Setting Video Snapshots	90
3.3.2	Searching Video Snapshots	91
3.4	Face Detection	92
3.4.1	Setting Face Detection	92
3.4.2	Searching Face Detection Snapshots.....	93

3.5	Face Count	94
3.5.1	Installing the Camera	94
3.5.2	Setting Face Count.....	95
3.6	Face Recognition	98
3.6.1	Enrolling Face Data.....	99
3.6.2	Setting Face Groups	102
3.6.3	Synchronizing Face Database	103
3.6.4	Defining Access Schedule.....	104
3.6.5	Setting Recognition Alerts	107
3.6.6	Configuring Face Recognition Database	108
3.6.7	Backing up Face Database	109
3.6.8	Face ID — Live Recognition Profiles	109
3.6.9	Viewing and Searching for Face Recognition Events	110
3.6.10	Tracking Recognized Faces.....	111
3.6.11	Integrating Face Recognition to Access Control.....	114
3.6.12	Batch Enrolling Faces and Access Cards	117
3.7	Face Detection by Camera	121
3.7.1	Configuring for FD Cameras	121
3.7.2	Face List — Live Face Detection.....	122
3.8	Privacy Mask Protection	123
3.8.1	Setting a Privacy Mask.....	123
3.8.2	Granting Access Privileges to Recoverable Areas	124
3.9	Panorama View	125
3.8.1	The Main Window.....	125
3.8.2	Stitching a Panorama View with Overlapping Areas.....	126
3.8.3	Easy Mode with No Overlapping Areas	128
3.8.4	Accessing a Panorama View	130
3.10	Video Defogging	131
3.11	Video Stabilization	132
3.12	Wide Angle Lens Dewarping	133
3.13	Crowd Detection	135
3.14	Advanced Scene Change Detection	137
3.15	Advanced Unattended Object Detection	139
3.16	Advanced Missing Object Detection	142
3.17	Text Overlay	144
3.18	Fisheye View	145
3.18.1	Setting up a GV-Fisheye Camera	146
3.18.2	Setting up a Third-Party Fisheye Camera.....	148

3.18.3	Object Tracking	150
3.19	Video Analysis by Camera	155
3.20	Heat Map	158
3.20.1	Enabling Heat Map	158
3.20.2	Accessing the Heat Map in Recordings	160
3.21	Event Alert through E-mail Notification	161
3.22	PTZ Object Tracking	162
3.22.1	Dual-Camera Tracking	162
3.22.2	Single Camera Tracking	164
3.22	Panoramic PTZ Object Tracking	166
3.19.1	Accessing the Live View	166
3.19.2	Automatic Object Tracking	167
3.23	Specifications	171

4

Video Playback 173

4.1	Playing back on ViewLog	174
4.1.1	ViewLog Control Panel	176
4.1.2	Adjusting the Camera View	179
4.1.3	Bookmarking Video Events in ViewLog	180
4.1.4	Merging and Exporting Video	181
4.1.5	Saving, Printing & Copying Images	186
4.1.6	Adjusting Distorted Views	187
4.2	Object Search	188
4.3	Advanced Log Browser	190
4.3.1	Filter Settings	191
4.4	Remote ViewLog Service	192
4.4.1	Retrieving Recorded Videos from GV-VMS	192
4.4.2	Retrieving Images of Object Index	193
4.4.3	Resuming Backup	193
4.4.4	Exporting and Importing Host List	194
4.4.5	Displaying Sub Stream	194
4.5	Single Player	195
4.5.1	Single Player Window	195
4.6	Specifications	196

5 Backup, Deletion and Repair 198

5.1 Backing up Log Data	198
5.2 Backing up Recorded Files.....	199
5.3 Deleting Recorded Files.....	202
5.4 Repairing Damaged File Paths	203
5.5 Repairing Damaged Video Files	204

6 I/O Applications 207

6.1 Setting I/O Devices	207
6.1.1 Adding I/O Devices.....	208
6.1.2 Setting the Input and Output Devices	209
6.1.3 Latch Trigger	210
6.1.4 Keeping Last Toggle Status	212
6.1.5 Setting PLC I/O devices	214
6.2 Advanced I/O Applications	216
6.2.1 Setting up Actions upon Input Trigger.....	217
6.2.2 Moving PTZ Camera to Preset Points upon Input Trigger	218
6.2.3 Setting Momentary and Maintained Modes.....	219
6.2.4 Deactivating Alarm and Alert upon Input Trigger	220
6.2.5 Other I/O Application Functions	221
6.3 I/O Devices in Content List	222
6.4 Visual Automation	223

7 Remote Viewing..... 225

7.1 Remote Viewing using a Web Browser	226
7.2 WebCam Server Settings	229

7.2.1	General Settings.....	229
7.2.2	Server Settings.....	230
7.2.3	Video Settings.....	231
7.2.4	Audio Settings.....	232
7.2.5	JPG Settings.....	233
7.2.6	UPnP Settings.....	234
7.2.7	Network Port Information.....	235
7.2.8	Mobile Service.....	236
7.3	Single View Viewer.....	237
7.3.1	Adjusting Video Quality.....	239
7.3.2	Control Panel.....	240
7.3.3	Configuring Single View Viewer Options.....	241
7.3.4	PTZ Control Panel.....	244
7.3.5	Visual PTZ Control.....	245
7.3.6	I/O Control.....	246
7.3.7	Visual Automation.....	247
7.3.8	Picture-in-Picture View.....	248
7.3.9	Picture-and-Picture View.....	249
7.4	Multi-Window Viewer.....	250
7.5	JPEG Image Viewer.....	251
7.6	Playing Back Events.....	252
7.6.1	Event List Query.....	252
7.6.2	Remote Playback.....	253
7.7	Remote ViewLog.....	254
7.8	Download Center.....	255
7.9	GV-Edge Recording Manager.....	256
7.10	Mobile Phone Applications.....	257
7.11	Web Browsers on Smartphones.....	257

8

E-Map Application..... 260

8.1	The E-Map Editor.....	260
8.1.1	The E-Map Editor Window.....	261
8.1.2	Creating an E-Map.....	262
8.1.3	Creating an E-Map for a Remote Host.....	265

8.2 Starting E-Map	266
8.2.1 Setting up the Pop-up Map.....	266
8.2 3D E-Map Display	268
8.2.1 3D E-Map Display	268
8.2.2 Utilizing the 3D E-Map Icons	269
8.4 Remotely Accessing E-Map	270
8.4.1 The Remote E-Map Window	271
8.4.2 Accessing E-Maps of Multiple Hosts.....	272
8.4.3 Configuring the Remote E-Map.....	273
8.4.4 Viewing Event List and Playing back Videos	275
8.5 E-Map Server	275
8.5.1 Installing E-Map Server	275
8.5.2 The E-Map Server Window	276
8.5.3 Setting up E-Map Server	277
8.5.4 Connecting to E-Map Server	277

9

Useful Utilities.....280

9.1 Dynamic DNS	280
9.1.1 Running Dynamic DNS	281
9.1.2 Registering Domain Name with DDNS	281
9.1.3 Starting Dynamic DNS	282
9.2 Watermark Viewer	283
9.2.1 Activating Watermark Protection.....	283
9.2.2 Running the Watermark Proof.....	283
9.2.3 The Main Window.....	284
9.3 Windows Lockup	285
9.3.1 The GV-Desktop Screen	285
9.3.2 GV-Desktop Features.....	286
9.3.3 Token File for Safe Mode	288
9.4 Authentication Server	289
9.4.1 Installing the Server.....	289
9.4.2 The Main Window.....	290
9.4.3 Creating Clients.....	291
9.4.4 Creating User Accounts	292
9.4.5 Importing Groups and Users from Active Directory	295

9.4.6	Starting the Server	298
9.4.7	Connecting GV-VMS to the Server	300
9.4.8	Remote Access from Control Center and Remote E-Map	302
9.5	Fast Backup and Restore.....	305
9.5.1	Running the FBR Program	305
9.5.2	Plugin Component.....	306
9.5.3	Customizing the Features	307
9.5.4	Backing up and Restoring Settings	308
9.6	Bandwidth Control Application	311
9.6.1	Installing the Bandwidth Control.....	311
9.6.2	The Main Window.....	312
9.6.3	Allowing Remote Control.....	313
9.6.4	Connecting to a WebCam Server	314
9.6.5	Controlling Specific WebCam Server.....	315
9.6.6	Setting up the Bandwidth	316
9.6.7	Block List Setup.....	317
9.6.8	General Setup	318
9.7	Language Setting.....	319
9.7.1	Installing the MultiLang Tool.....	319
9.7.2	Revising the Translated Text.....	320
9.7.3	Setting the UI Language to English.....	323
9.8	GV-SD Card Sync Utility.....	324
9.8.1	Installing GV-SD Card Sync Utility	324
9.8.2	Setting up GV-SD Card Sync Utility	325
9.8.3	The Main Window.....	328
9.9	The Media Man Tools Window	329
9.9.1	The Media Man Tools Window.....	329
9.9.2	Viewing Disk Drive Status	330
9.9.3	Adding a Disk Drive.....	332
9.9.4	Removing a Disk Drive.....	333
9.9.5	Logging in Automatically at Startup.....	334
9.9.6	Setting LED Panel	334
9.10	Alert Notifications through SNMP Protocol	337
9.11	Local and Remote Backup	338
9.11.1	Remote Backup.....	338
9.11.2	Local Backup.....	338
9.11.3	Advanced Settings	340
9.11.3.1	Advanced Settings for Local Backup	340

9.11.3.2	File Transfer Settings for Local Backup	341
9.12	Report Generator	343
9.13	GV-Cloud Center	343

10

Point-Of-Sale (POS)

Application.....	345
------------------	-----

10.1	Setting up Text Overlay	346
10.2	Filtering Transactions for a Particular item	347
10.3	Triggering Transaction Alarms.....	349
10.4	Mapping Codepage.....	351
10.5	Coloring Transactions of a Particular Item	352
10.6	Seeing the Receipt Details of a Particular Transaction	355
10.7	Filtering Transactions by a Keyword.....	361
10.8	Searching for and Playing back POS Events.....	364

Chapter 1

Configuring Main System	3
1.1 Installing GV-VMS	3
1.1.1 License	3
1.1.2 Minimum System Requirements	4
1.1.3 Options	5
1.1.4 Minimum Network Requirements	6
1.1.5 Installing GV-VMS	7
1.2 Getting Started	8
1.2.1 Main Screen	9
1.2.2 Adding Cameras	10
1.2.3 Accessing Live View	11
1.2.4 Enabling Recording	11
1.2.5 Playing Back Video	12
1.3 Recording Settings	13
1.3.1 Setting Global Recording Settings for All Cameras	14
1.3.2 Setting Recording Settings for Individual Cameras	16
1.3.3 Setting Up Video Storage Location	18
1.3.4 Setting Up Motion Detection	19
1.4 Live View and Layouts	22
1.4.1 Utilizing Live View Functions	22
1.4.2 Arranging Live View Layouts	24
1.4.3 Setting a Zoom Window	25
1.4.4 Setting a Scan Window	25
1.4.5 Setting a Popup Window	27
1.4.6 Setting Focus View	28
1.4.7 Automatic Switch among Different Live View Layouts	29
1.4.8 Adding GV-IP Decoder Box for Remote Monitor Display	29
1.5 Start Monitoring	30
1.6 System Configuration	31
1.6.1 Configuring General Settings	31
1.6.2 Customizing Startup Settings	33
1.6.3 Customizing Display Position and Panel Resolution	34

1.6.4	Setting up E-mail Notification	35
1.6.5	System Idle Protection	37
1.6.6	Configuring Fast Key Lock	38
1.7	Account and Password	38
1.7.1	Creating an Account	38
1.7.2	Configuring Account Settings	39
1.7.3	Changing or Retrieving Password at Login	41
1.7.4	Preventing Unauthorized System Termination.....	41
1.7.5	Setting a Startup Auto Login User.....	42
1.7.6	Setting Limits on Playback Time	42
1.8	Schedule	43
1.8.1	Creating a Schedule with Setup Wizard	44
1.8.2	Creating a Schedule Manually.....	46
1.8.3	Exporting and Importing Schedule Settings	47
1.9	System Log	47
1.9.1	Setting System Log.....	47
1.9.2	Viewing System Log	49
1.10	Other Functions	51
1.10.1	Setting Pop-up Live View.....	51
1.10.2	Adjusting to Daylight Saving Time	52
1.10.3	Setting Network Failure Detection	53
1.11	PTZ Camera.....	54
1.11.1	Accessing PTZ Control Panel and Auto Functions.....	55
1.11.2	Setting PTZ Idle Protection and Advanced Functions	57
1.12	QView	58
1.13	Storyline	59
1.13.1	Creating a Storyline in Live View	59
1.13.2	Creating a Storyline in Video Playback.....	60
1.13.3	Creating a Storyline in QView.....	60
1.13.4	Accessing the Storyline	61
1.14	GV-VR360 Dewarped View	61

Configuring Main System

1.1 Installing GV-VMS

1.1.1 License

GV-VMS V18.1 or later is a paid software that supports connection of up to 64 IP devices, and can connect up to 32 GV-IP devices upon initial purchase. If you need to connect more than 32 channels of GV-IP devices or connect with third-party IP devices, additional license(s) are required.

Supported Devices	Channels	License
GV-IP Devices Only	32 ch	Initial license required.
	64 ch	2 licenses required: <ul style="list-style-type: none"> • GV-VMS V18.1 or later initial license. • GV-VMS Pro license required, 32 ch per license.
GV-IP Devices + 3 rd -Party IP Devices	32 ch	2 licenses required: <ul style="list-style-type: none"> • GV-VMS V18.1 or later initial license. • 3rd-Party license, in increments of 1 ch.
	64 ch	3 licenses required: <ul style="list-style-type: none"> • GV-VMS V18.1 or later initial license. • GV-VMS Pro license, 32 ch per license. • 3rd-Party license, in increments of 1 ch.

IMPORTANT: Make sure your purchased GV-Dongle or software license has been inserted into or activated on the PC prior to running GV-VMS.

Note:

1. GV-USB Dongle comes in internal and external dongles. Internal dongle is recommended for the Hardware Watchdog function, which restarts the PC when Windows crashes or freezes.
2. For details on upgrading **GV-USB Dongle**, see *Chapter 8 Dongle Upgrade* in the [GV-VMS Quick Start Guide](#).
3. GV-VMS also allows users to license GV-VMS Pro and third-party cameras without using GV-USB dongle. For details, see the [technical notice](#) of **Software License**.
4. For a list of supported third-party IP camera models, please visit [GeoVision's website](#).

1.1.2 Minimum System Requirements

	GV-VMS (Up to 32 Channels)	GV-VMS Pro (Up to 64 Channels)
OS	64-bit Windows 10 / Server 2016	
CPU	4th Generation i5-4670, 3.4 GHz	4th Generation i7-4770, 3.4 GHz
Memory	8 GB RAM	16 GB RAM
Note:		
<ol style="list-style-type: none"> 1. To use the fisheye dewarping function, the graphic card must support DirectX 10.1 or above. 2. H.265 decoding and searching of face recognition events by face images requires 6th Generation Intel Desktop Processor (Skylake) or above. 3. The system requirements are determined in round-the-clock recording settings with live view only, while remote connections and video analysis being disabled. 		

1.1.3 Options

For the following optional devices of GV-VMS, contact your dealer for more information.

Optional Devices	Description
Internal USB Dongle	The USB dongle can provide the Hardware Watchdog function to the GV-VMS by restarting the computer when Windows crashes. You need to connect the dongle internally on the motherboard.
GV-COM V3	GV-COM V3 can add 1 RS-232 / RS-485 serial port through the GV-VMS' USB port.
GV-IR Remote Control	GV-IR Remote Control allows you to control GV-VMS at the maximum operation distance of 7 m (22.97 ft).
GV-IO Box Series	GV-IO Box series (4E / 4 Ports / 8 Ports / 16 Ports) provide 4 / 8 / 16 inputs and relay outputs and support both DC and AC output voltages, with optional support for Ethernet module and 4E additionally supporting PoE, TCP/IP and RS-485 connection.
GV-Joystick V2	GV-Joystick V2 allows you to easily control PTZ cameras. It can be either plugged into the GV-VMS for independent use or connected to GV-Keyboard.
GV-Keyboard V3	GV-Keyboard V3 is used to program and operate GV-VMS and PTZ cameras. Through RS-485 configuration, it can control up to 36 GV-VMS. In addition, you can connect PTZ cameras directly to the keyboard for PTZ control.
GV-NET I/O Card V3.2	GV-NET/I/O card V3.2 provides 4 inputs and 4 relay outputs. It supports both DC and AC output voltages and provides a USB port as well.

1.1.4 Minimum Network Requirements

The data transmitting capacity of GV-VMS depends on the number of Gigabit connections available. The numbers of Gigabit network cards required to connect 64 channels are listed below according to the resolution and codec of the source video.

Codec	Resolution	Bitrate Used (Mbps)	Total FPS for 64 ch	Gigabit Network Cards Required	Max. Channels Supported per Network Card
H.264	1.3 MP	5.05	1920	1	Max. 64 ch / card
	2 MP	7.01	1920	1	Max. 64 ch / card
	3 MP	10.48	1280	1	Max. 64 ch / card
	4 MP	11.65	960	2	Max. 50 ch / card
	5 MP	16.48	640	2	Max. 38 ch / card
	8 MP	17.14	1600	2	Max. 38 ch / card.
	12 MP	16.67	960	2	Max. 38 ch / card
H.265	3 MP	7.06	1920	1	Max. 64 ch / card
	4 MP	9.44	1600	1	Max. 64 ch / card
	5 MP	7.52	1920	1	Max. 64 ch / card
MJPEG	1.3 MP	32.36	1920	3	Max. 22 ch / card
	2 MP	44.96	1920	4	Max. 16 ch / card
	3 MP	38.73	1280	4	Max. 18 ch / card
	4 MP	40.35	960	4	Max. 17 ch / card
	5 MP	30.48	640	3	Max. 22 ch / card
	8 MP	58.52	1600	6	Max. 12 ch / card
	12 MP	65.98	960	6	Max. 11 ch / card
Note: The network requirements may vary depending on the bitrate of the streams.					

1.1.5 Installing GV-VMS

Before You Start

For optimal performance, please refer to the following recommendations before installing the GV-VMS:

- It is highly recommended to use separate hard disks; one for installing Windows OS and GV-VMS software, while the other for storing recorded files and system logs.
- When formatting the hard disks, select NTFS as the file system.
- Due to GV-VMS storing video files of multi channels simultaneously, the drive containing the video files will be fragmented with the files scattered all over the drive, therefore it is unnecessary to perform disk defragmentation regularly.
- Since the size of transmitted data from IP cameras may be quite large and reach beyond the transfer rate of a hard disk, you should note the total of recording frame rates that you can assign to a single hard disk, as listed below:



Frame rate limit in a single hard disk

Video Resolution	H.264		H.265	
	Frame Rate (fps)	Bitrate (Mbps)	Frame Rate (fps)	Bitrate (Mbps)
1.3 MP (1280 x 1024)	660	5.05	N/A	N/A
2 MP (1920 x 1080)	660	7.01	N/A	N/A
3 MP (2048 x 1536)	440	10.48	660	5.35
4 MP (2048 x 1944)	330	11.65	550	7.74
5 MP (2560 x 1920)	220	16.48	660	6.73
8 MP (3840 x 2120)	550	14.13	N/A	N/A
12 MP (4000 x 3000)	330	14.47	N/A	N/A

Note: The data above was determined using the bitrate listed above and hard disks with average R/W speed above 110 MB/s.

The frame rate limit is based on the resolution of video sources. The higher the resolutions, the lower the frame rates you can assign to a single hard disk. In other words, the higher the frame rates you wish to record, the more hard disks you'll need. For detailed information of recording frame rates, refer to the user's manual of the IP camera that you wish to connect to.

Installing GV-VMS

1. Download GV-VMS by selecting **Primary Applications** from the drop-down list and clicking **Download**  of GV-VMS on [GeoVision's website](#).
2. If you are using a USB dongle, insert the dongle to your computer. See *1.1.1 Licnese* for connections requiring dongle license(s).
3. To install USB driver, select **Drivers, FW, Patch** from the drop-down list, and click **Download** icon  of **GV-Series Card Driver / USB Devices Driver**.
 - To verify the driver is installed correctly, go to Windows Device Manager and expand **DVR-Devices**. You should see the **GV-Series USB Protector**.

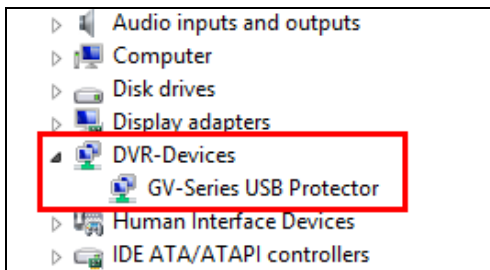



Figure 1-1

1.2 Getting Started

When you run GV-VMS for the first time, the system will prompt you for a Supervisor ID and Password.

1. Type the desired **ID**, **Password** and a **Hint** to remind you of the password.
2. Optionally set up the following functions
 - **E-Mail List:** Enter e-mail addresses used to receive the password when forgotten.
 - **Auto Login:** Allows auto login as the current user every time when the system is launched.
 - **Allow removing password System:** It is recommended to select this option allowing removal of the password database once you forget passwords. For details, see the same option in *Account and Password* later in this chapter.
 - : Click to open the onscreen keyboard to enter the login information.
3. Click **OK**. The main screen of GV-VMS and a dialog box appears.
4. To choose how to save your system database, select **Microsoft Office Access Database** or **Microsoft SQL Server** and fill out the required fields.
5. Upon first-time starting of the GV-VMS, you are prompted with the **Automatic Setup** dialog box to assist you in quickly adding IP devices to the GV-VMS.

1.2.1 Main Screen



Figure 1-2

Name	Description
Login ID	Click to manage accounts and passwords for accessing GV-VMS.
Audio	Click to control the volume of your PC.
Home	Shows the live view of connected cameras.
ViewLog	Shows a timeline of recorded events for playback. Brings up these options when Home is selected: <ul style="list-style-type: none"> • Monitor: Start / Stop monitoring, I/O monitoring and schedule monitoring • Network: Enable Webcam Server and connection to other GeoVision software. • Tools: Show / hide volume indicator and set up Object Index.
Toolbar	<ul style="list-style-type: none"> • Configure: Set up camera, recording, system, schedule, video processing and I/O devices. • Content List: Access live view layout, camera and I/O device lists and panorama view. Brings up these options when ViewLog is selected:

- **Display Play Panel:** Display or hide the ViewLog timeline. This function is grayed out when the **Pinned** button is selected in the bottom-right corner.
- **Tools:** Manage event search, system log, event backup and event export.
- **Configure:** Apply video effects and text overlay during playback.
- **Content List:** Manage playback layout and access camera list.

Exit Click to Minimize or Exit GV-VMS.

1.2.2 Adding Cameras

To add cameras to the GV-VMS, click **Home**  > **Toolbar**  > **Configure**  > **Camera Install**. When the camera list is empty, the Automatic Setup dialog box automatically pops up.

Click **Automatic Setup** to search for IP cameras on the LAN. Then select / deselect the desired cameras listed and click **Apply**.

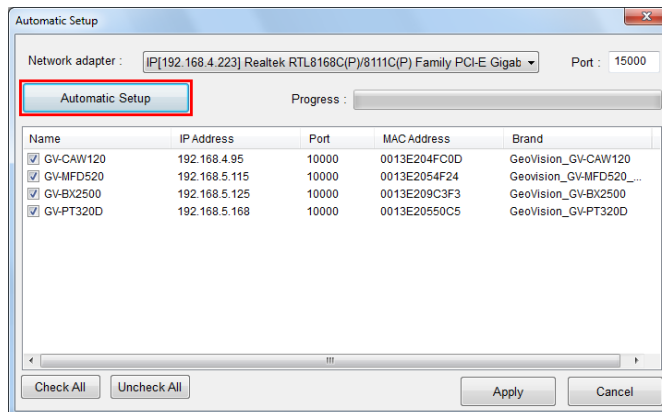

Figure 1-3



Note:

1. The default login ID and password of connected cameras is **admin / admin**. To specify a different login credential, double-click the camera. If you select **Apply All**, the login info will be applied to all selected cameras.
2. When cameras are added for the first time, they are automatically assigned to the live view grid.

To add cameras using manual setup, camera scan or GV-IP Device Utility, refer to *Adding IP Cameras* in Chapter 2.

1.2.3 Accessing Live View

After adding cameras, you can access camera live view by dragging the camera in the Content List to the live view grid.

Click **Home**  > **Toolbar**  > **Content List** . Then click **Camera** in the content list to see the list of cameras added, and drag the desired cameras to the live view grid.

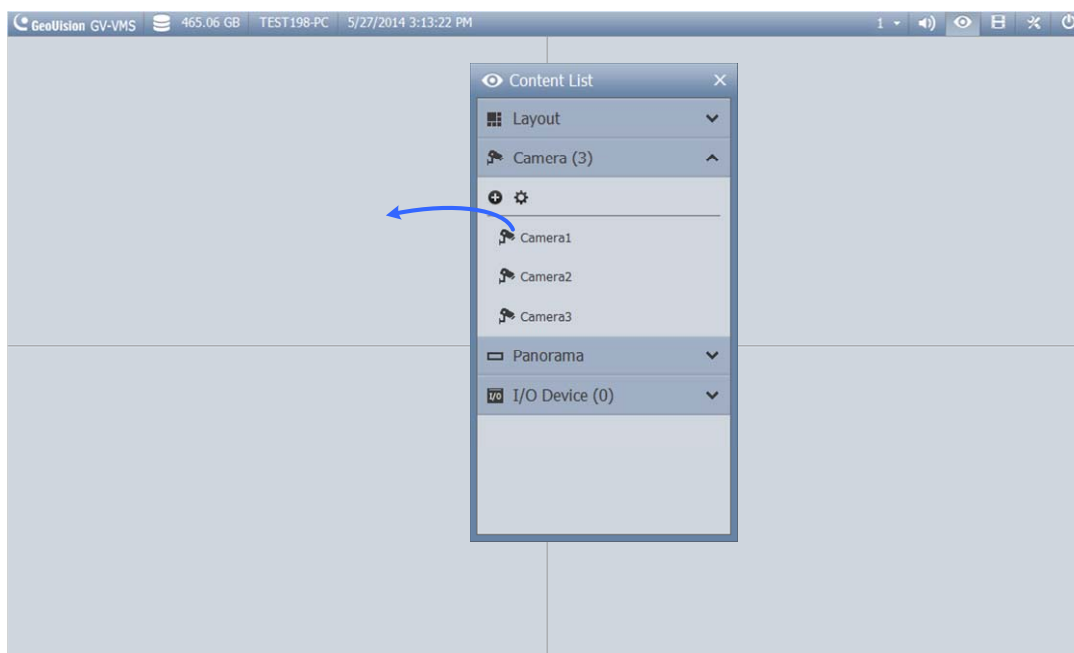





Figure 1-4

For details on the live view, see *Live View and Layouts* later in this chapter.

1.2.4 Enabling Recording

To start recording, click **Home**  > **Toolbar**  > **Monitor**  > **Start All Monitoring**. Alternatively, select the cameras you want to start monitoring.

By default, every camera records with the following settings:

Default Recording Settings	
Recording Mode	Motion Detection
Resolution / Codec	The camera's current resolution / codec will be used.

- To change **recording mode**, see *Record Settings* later in this chapter.
- To change **resolution** and **codec**, see *Configuring Video Setting* in Chapter 2.

1.2.5 Playing Back Video

Instant Playback

You can instantly play back the recorded video of a single camera from the camera live view by clicking the **Instant Playback** button.

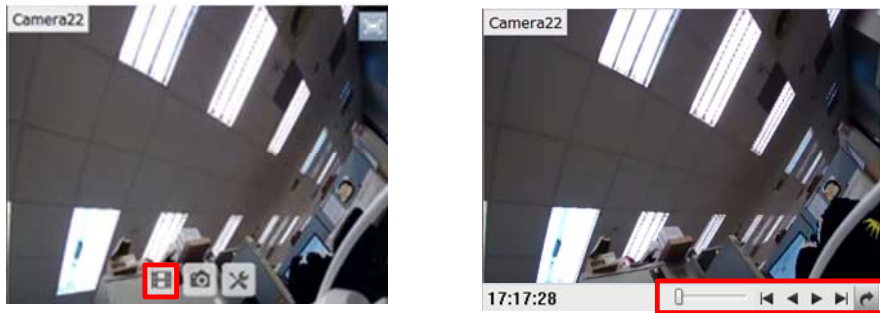





Figure 1-5

ViewLog

For comprehensive playback functions, click **ViewLog**  on the top-right corner.

For details on the ViewLog player, see *Video Playback* in Chapter 4.

1.3 Recording Settings

To configure the recording setting of the cameras, click **Home**  > **Toolbar**  > **Configure**  > **System Configure** > **Record Setting**. The Recording Setting dialog allows you to configure the following settings:

- 1.3.1 *Setting Global Recording Settings for All Cameras*
- 1.3.2 *Setting Recording Settings for Individual Cameras*
- 1.3.4 *Setting Up Motion Detection*

By default, the system has the following recording storage settings.

Default Data Storage Settings		
Storage Location	Recorded Files	D:\Record\ <camxx audxx="" folder>.<="" or="" td=""> </camxx>
	Event Database Files	C:\GV-VMS\CameraDBs\
	Storyline Files	C:\GV-VMS\StoryLine\
Recycle Function		Enabled with recycling threshold set to 32 G.

Note: A storage folder is created automatically upon assigning the camera ID. For example, camera of ID 1 will be saved in the folder D:\Record\Cam01.

1.3.1 Setting Global Recording Settings for All Cameras

You can configure global recording settings that will be applied to all cameras, such as maximum length of each video clip, recycling function and the actions to take upon recording errors.

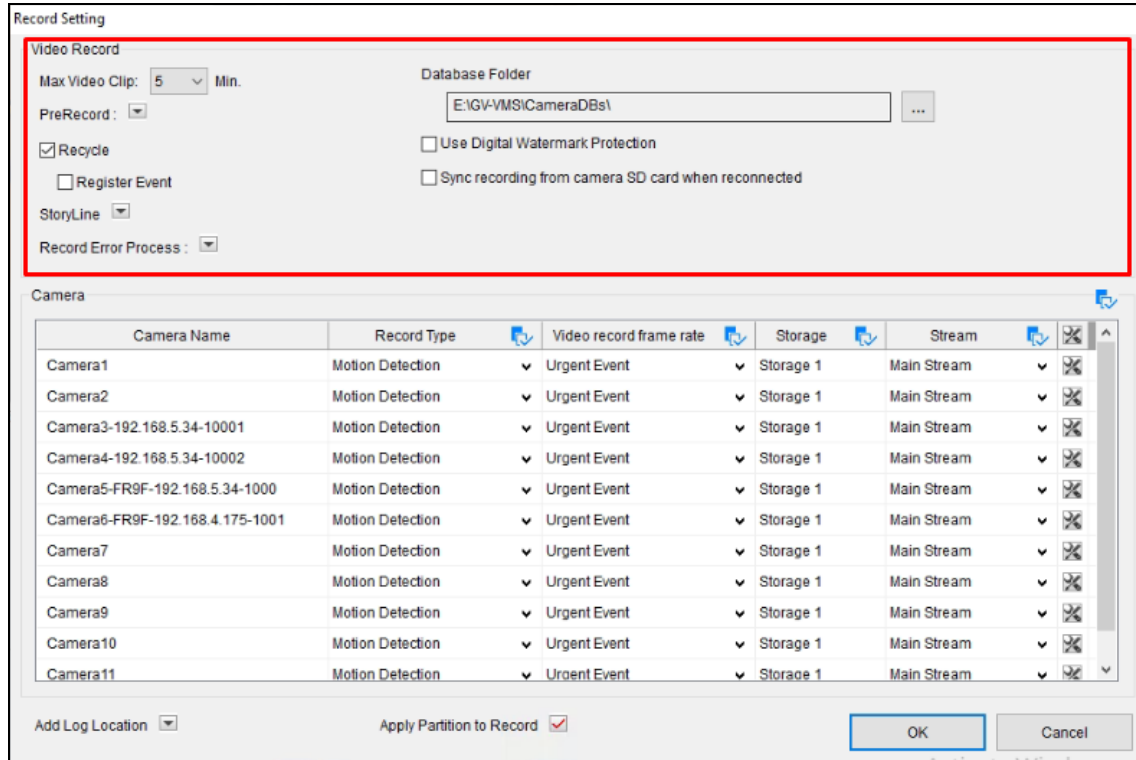

Figure 1-6

[Video Record]

- **Max Video Clip:** Specifies the maximum time length of each recorded file (from 1 to 5 minutes), i.e. if you select **5 Min**, a 30-minute event will be chopped into six 5-minute event files.
- **PreRecord:** Configures Post-Rec and Pre-Rec.
 - ⊙ **Post-Rec:** Keeps on recording for a set period of time after an event stops.
 - ⊙ **Pre-Rec:** Records video for a set period of time before an event starts. Specify the number of video clips to pre-record and specify the number of seconds per video clip. For example, if you specify **3 video clips** and **5 seconds**, 15 seconds of video, 3 files of 5 seconds each, before each motion or input event are recorded.
 - ⊙ **Urgent / General Event:** Select Urgent Event to record full frame rates or select General Even to record key frames only.
- **Recycle:** When selected, the oldest recordings will be deleted when the system requires storage space for new files. If it is not selected, the system will stop recording when disk space is full. Select **Register Event** if you want to recycle Register Events from System Log.

- **Use Digital Watermark Protection:** Select to watermark all recorded videos. For details, see *Watermark Viewer* in Chapter 9.
- **Sync recording from camera SD card when reconnected:** Retrieves and restores recordings from the SD cards of cameras selected when reconnecting after a temporary disconnection. After enabling, select the cameras for this function to be applied to by checking the checkboxes beside **Camera Name**. Recordings that are synced from the SD cards of recorded cameras are displayed in yellow within the Timeline of ViewLog.

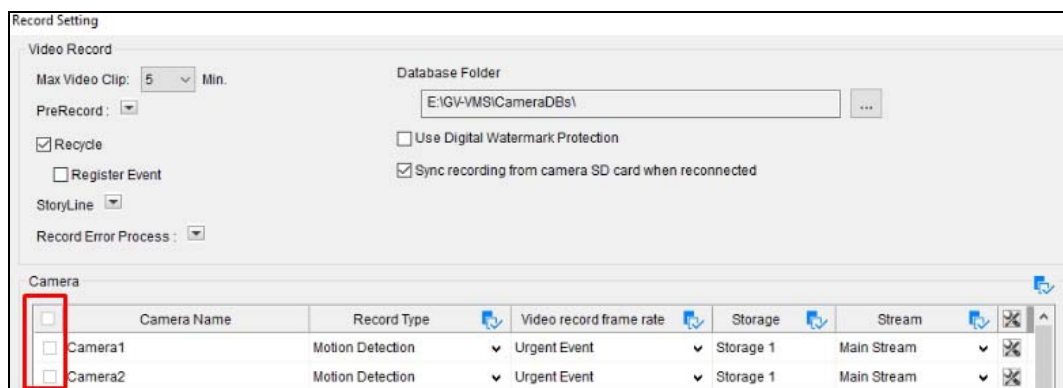



Figure 1-7

Note: This function is not supported by GV-ABL / AVD / EBD / TBL / TDR / TVD series and ONVIF cameras not of Profile G conformant, and only available on GV-VMS V18.1 or later.

[Storyline]

- **Keep Image Ratio:** Keeps the image ratio of the recorded storyline videos.
- **Resolution:** Specifies the resolution of the recorded storyline videos.
- **Path:** The default storage path for Storyline is at C:\GV-VMS\ Storyline\. Click  to specify a new storage path.

Note: To record a storyline, see *Storyline* later in this Chapter.

- **Record Error Process:** Configures for which actions to take when there is a recording error.
 - ⊙ **Invoke Alarm:** Activates computer alarm by playing the selected sound file.
 - ⊙ **Invoke to Send Alerts:** Sends e-mail notification. See *Setting Up Email Notification* later in this chapter to configure.
 - ⊙ **Register Event:** Records the error to System Log.
 - ⊙ **Output Module:** Triggers the selected output device. See *Chapter 6 I/O Applications* to configure output devices.

[Database Folder] The default storage path for Event Database (.db files) is at C:\GV-VMS\CameraDBs\. Click to specify a new storage path. Note that the storage path for the actual recordings is specified in the **Add Log Location** option. For details, see *Setting Up the Video Storage Location* later in this chapter.

1.3.2 Setting Recording Settings for Individual Cameras

You configure the recording mode and video storage location for the selected camera(s) only.

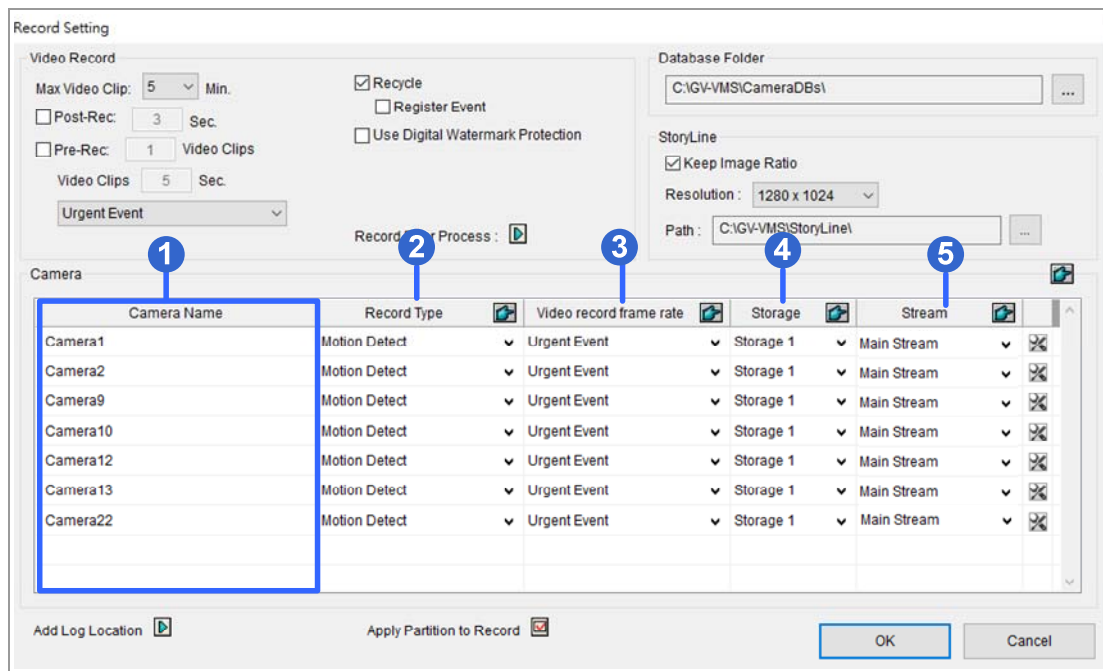

Figure 1-8

1. Select the camera you want to configure. Hold the Shift key to select multiple cameras if needed.
2. Under Record Type, select **Disable**, **Motion Detection** or **Round-the-Clock**.
3. You can set different recording frame rates. Select **Urgent Event** to record in full frame rate. Select **General Event** to record only the key frames.

The frame rate for General Event and Urgent Event can be defined in the camera's General Setting dialog box (Figure 2-13). Normally, you would set a higher frame rate for Urgent Events (e.g. full frame) and a lower frame rate for General Events (e.g. key frame only).

4. If there are more than one storage locations, click the Arrow button next to **Storage** to specify where to store the recorded videos. See *Setting Up the Video Storage Location* later in this section.

- Under **Stream**, select the stream(s) you want to record. By default, **Main Stream** is set to record high-resolution video images. Select **Sub Stream** to record lower-resolution video images. Select **Main Stream and Sub Stream** to record both streams simultaneously.

Note:

- Refer to *Configuring General Settings* in Chapter 2 for setting the frame rate for General Event and Urgent Event.
- In Round-the-Clock mode, for motion recordings, the **Video Record Type** setting in the Advanced Motion Detection Setup dialog box has priority over the **Video record frame rate** setting in the Record Setting dialog box (Figure 1-7). For example, if you select **General Event** in the Record Setting dialog box, but select **Urgent Event** in the Advanced Motion Detection Setup dialog box, the motion events will be recorded in full frame rate as Urgent Event.

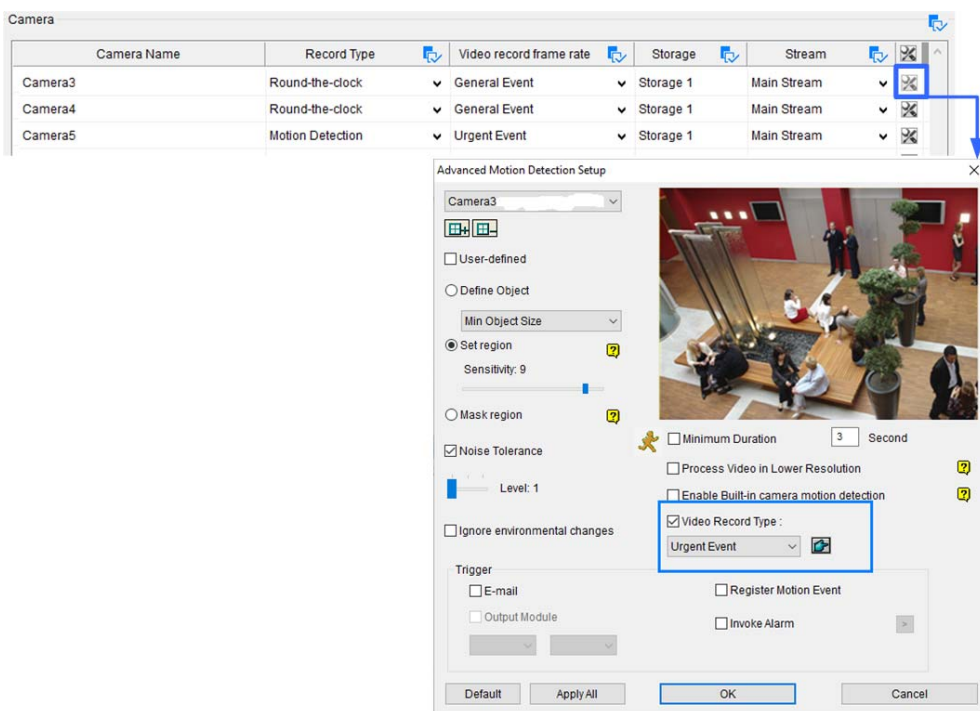

Figure 1-8

See *Setting Up Motion Detection* later in this section for details.

- Recording both main and sub streams will require significantly more hard drive space than single-stream recording.

1.3.3 Setting Up Video Storage Location

Add Log Location

You can create a maximum of 24 storage groups with different storage locations. The default storage location is D:\Record\.

1. Open the Recording Setting dialog box (Figure 1-6), select a camera and click  next to **Add Log Location**. This dialog box appears.

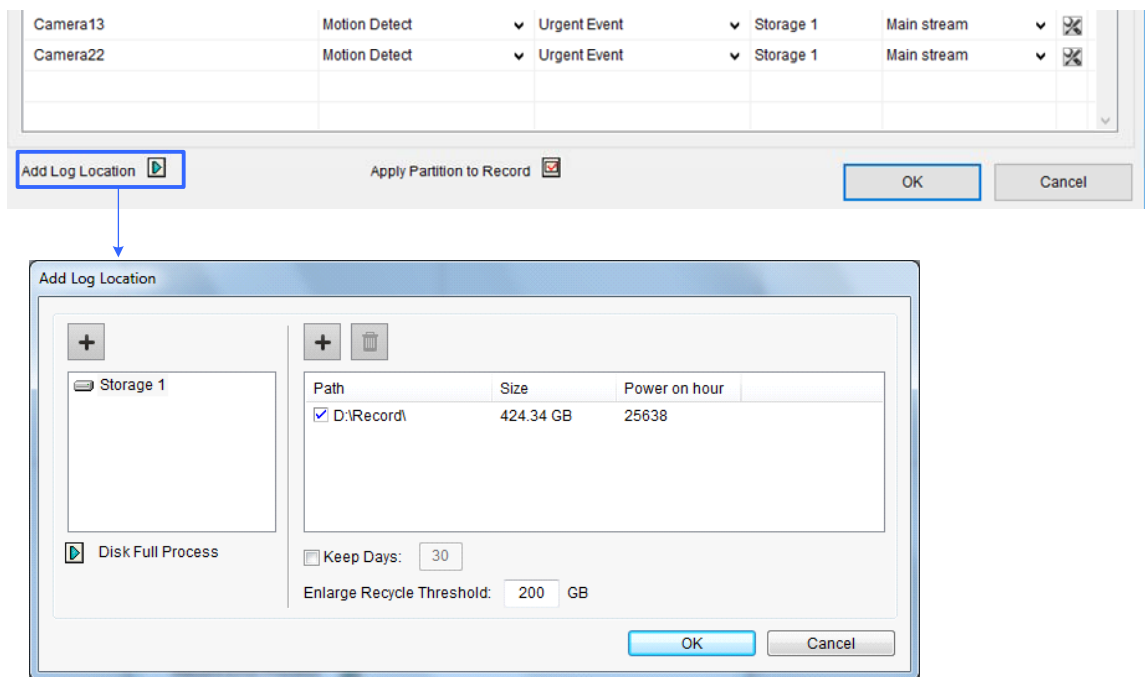





Figure 1-9

2. To add a new folder in the first storage group, click  above Path and select a folder. Only 1 folder can be assigned as storage folder per partition (e.g. only 1 folder in D drive).
3. To add a new storage group, click  in the top-left corner and repeat the step above to assign at least one folder to the storage group.
4. Select **Keep Days** and specify the number of days to keep the video files in storage.
5. In the **Enlarge Recycle Threshold** field, adjust the recycle threshold (minimum 5 GB; maximum 999 GB) if needed. Recycle threshold is the file size at which the recycling begins.
6. To specify the actions to take when hard disks become full, click  next to **Disk Full Process**.
 - **Invoke Alarm:** Activates computer alarm by playing the selected sound file.
 - **Invoke to Send Alerts:** Sends e-mail notification. See *Setting Up Email Notification* later in this chapter to configure.

- **Register Event:** Records the error to System Log.
- **Output Module:** Triggers the selected output device. To see how to set up I/O devices, refer to *Chapter 6 I/O Applications*.

7. Click **OK**.

Note: If the designated storage space is not big enough to keep all video files for the defined days, the **Recycle Threshold** setting will override the **Keep Days** setting.

Apply Partition to Record

The GV-VMS can automate the configuration of recording paths for multiple camera channels. Each of your cameras will be equally distributed to an assigned recording path after you have set up the storage locations.

1. Open the Recording Setting dialog box and click **Apply Partition to Record**. The Apply Partition to Record dialog box appears.
2. Select the desired recording paths (at least one) to store camera recordings and click **OK**.

1.3.4 Setting Up Motion Detection

The motion detection settings will be applied to motion events in both Round-the-Clock mode and Motion mode. The following features are available to prevent false motion detection:

- **Object Size:** Set a minimum and maximum object size to only detect objects within the size range
- **Sensitivity:** Designate up to 10 levels of motion detection sensitivity for each outlined area
- **Mask Region:** Mask off unwanted areas for monitoring, such as cloud and tree movement
- **Noise Tolerance:** Ignore video noise when the lighting condition is poor or changed
- **Ignore environmental changes:** Ignore changes such as rain, snow and tree movement
- **Minimum Duration:** Set the minimum duration for which motions must persist for the system to issue a motion alarm

1. Open the Recording Setting dialog box (Figure 1-6), select a camera and click button. This dialog box appears.

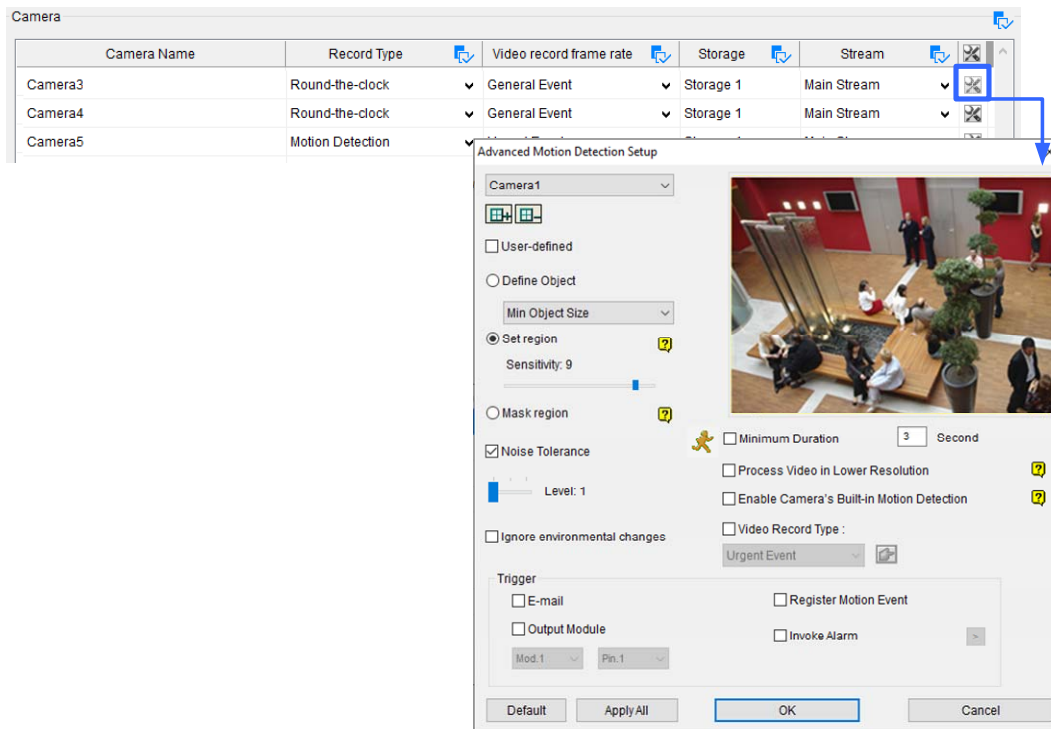

Figure 1-10

2. You can refine motion detection by setting either Object Size or Region Sensitivity.
 - **Define Object:** Limits motion detection to objects within a size range. Select **User-defined** and set the **Min. Object Size** and **Max. Object Size** in the respective drop-down lists.
 - **Set Region Sensitivity:** Sets different detection sensitivities for different parts of the camera image. Uncheck **User-defined**, adjust the sensitivity level by moving the slider, and drag an area on the image. You can create several areas with different sensitivity levels. You can use the **Add/Cut Mask** buttons to create irregular shapes. By default, the entire image is set to sensitivity level 9.
3. To ignore motions in a certain area, click **Mask Region**, and drag an area on the image.
4. The following options are available to further reduce false alarm:
 - **Noise Tolerance:** Enable to ignore video noise and move the slider to adjust the level. The higher the level, the more tolerant the system is to video noise.
 - **Ignore environmental changes:** Ignores environmental changes such as rain or snow. When selected, objects moving steadily and repeatedly in the same direction for over 1.5 seconds will be filtered out and ignored.
 - **Minimum Duration:** Sets the minimum duration for which motions must persist for the system to issue a motion alarm. Specify the minimum duration in seconds (up to 60).

5. You can reduce CPU loading by selecting **Process Video in Lower Resolution**. When enabled, GV-VMS compresses live view into a lower resolution before GV-VMS detects if there is motion, which reduces CPU loading, but may affect accuracy.
6. By default, all cameras connected to GV-VMS use the motion detection function by the VMS. You can optionally select **Enable Camera's Built-in Motion Detection** to use the built-in motion detection of the camera instead, when applicable.

Note: This function is only available on GV-VMS V18.1 or later.

7. To set the frame rate setting for motion events, click **Video record frame rate** and select **Urgent Event** or **General Event**. Normally, you would set a higher frame rate for Urgent Events (Ex: full frame) and select Urgent Event here for motion events. See *Configuring General Setting* in Chapter 2 to modify the frame rates of general and urgent events.
8. Under Event Trigger, select the actions to take when motion is detected.
 - **E-mail:** Sends e-mail notification. See *Setting Up Email Notification* later in this chapter to set.
 - **Output Module:** See *Chapter 6 I/O Applications* for I/O device setup.
 - **Register Motion Event:** Registers motion events to System Log.
 - **Invoke Alarm:** Activates computer alarm by playing the selected sound file.
9. Click **OK** to save your settings.

Note:

1. You can only enable motion detection either by sensitivity or by object size at a time.
 2. By default, the entire camera view is set to a motion sensitivity level of 9 with **Noise Tolerance** and **Process Video in Lower Resolution** functions enabled.
-

1.4 Live View and Layouts

This section describes the functions on the camera live view and how to create new live view layouts.

1.4.1 Utilizing Live View Functions

Live View Icons

Place the mouse cursor on the camera live view to see the icons below.

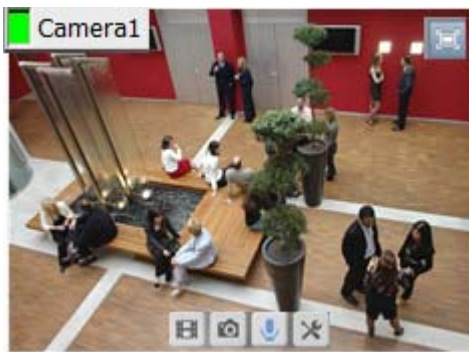











Figure 1-11



Icons	Functions
Instant Play 	Plays back the video recorded.
Snapshot 	Captures a snapshot of the current live view.
Talk Back Toggle / Push-to-Talk 	Talk to the surveillance site. For details, refer to [The behavior of the talk back button], <i>Configuring General Settings</i> later in this chapter.
Tools 	<p>Includes the following options:</p> <ul style="list-style-type: none"> ■ Monitor: Starts monitoring the camera. ■ Properties: <ul style="list-style-type: none"> ⊙ Show Caption: Shows camera name on live view. ⊙ Keep Image Ratio: Locks aspect ratio of the camera image. ■ Close: Removes the camera from the layout grid. <p>The following options are available when related function is enabled or supported:</p> <ul style="list-style-type: none"> ■ Set to Wave Out: Enables live view audio. (See <i>Configuring Audio Setting</i>, Chapter 2)

Tools 	<ul style="list-style-type: none"> ■ PTZ Control: Enables PTZ functions. (See <i>PTZ Camera</i> later in this chapter) ■ Add to bookmark: Bookmarks a scene to watch later in ViewLog player. The function is only available when the channel is recording. ■ Storyline: Records a sequence of short video clips of a specific incident. (See <i>Storyline</i> later in this chapter)
Zoom 	Switches the live view to full screen. If there is a designated Zoom window, clicking the Zoom button will display the live view in the zoom window instead.
Volume Indicator 	Display an audio volume indicator on the top-left corner of the camera live view. Click Home  > Toolbar  > Tools  > Audio > Show Volume Indicator .
<p>Note: When PTZ Control is enabled on a PTZ camera, double-clicking the live view will make the camera zoom in instead of switching to full screen.</p>	

Functions on Live View and Content List

The live view screen can be controlled using the actions below.

Actions	Functions
Mouse scroll	Zooms in or out on the live view.
Double-click	Displays the live view in full screen.

In the Content List (**Home**  > **Toolbar**  > **Content List**), right-click a camera to access the following options, when enabled or supported:

- **Monitor:** Starts monitoring the camera. (See *Start Monitoring* later in this section)
- **Video Process:** Opens the Video Processing dialog box. (See *Chapter 3 Video Analysis*)
- **Set to Wave Out:** Enables live view audio. (See *Configuring Audio Setting*, Chapter 2)
- **Talk Back Toggle:** Talks to the surveillance site from the PC. (See *Configuring Audio Setting*, Chapter 2)
- **Focus View Setup:** Creates up to 7 closed-up views in a camera. (See *Setting Focus View* later in this section)
- **PTZ Setup:** Enables PTZ functions. (See *PTZ Camera* later in this chapter)
- **Fisheye Settings:** Opens the Fisheye Settings dialog box. (See *Fisheye View*, Chapter 3)

Audio Broadcasting

When necessary, the GV-VMS operator can broadcast audio to multiple cameras simultaneously with the speaker function.

Note: This function is not supported by cameras connected through RTSP protocol.

1. Click **Home**  > **Toolbar**  > **Tools**  > **Audio Broadcast**. This window appears.

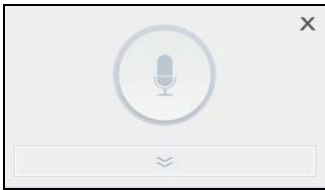



Figure 1-12

2. Click the **Down** arrow button to select the cameras you wish to broadcast audio to.
3. To start audio broadcasting, press and hold the **Push to Broadcast** button  while talking to the microphone connected to the computer of the GV-VMS.

1.4.2 Arranging Live View Layouts

1. In the Content List, click **Layout**.



Figure 1-13

2. To add a layout, click **Add**  and click **Add Layout**. The Add New Layout dialog box appears.
3. Name the new layout and select one of the three available methods under Layout Setup to define a layout and click **OK**.
4. If you select **Customize** in the step above, the Customize Layout dialog box will appear.

- a. Click **Reset** to specify a dimension for the grid if needed.
- b. Select multiple squares and click **Merge** to create a larger square.
- c. Click **OK** when you are done.

A message appears. Click **Yes** if you want to automatically assign the cameras to the new layout.



Tip: You can right-click a layout in the Content List to access other functions to arrange the layout.

1.4.3 Setting a Zoom Window

You can designate a Zoom Window to quickly see a close-up view of the camera image without changing the rest of the live view layout.

Note:

1. Up to two Zoom Windows can be created on each live view layout.
 2. When there are two Zoom Windows, GV-VMS will alternate between the first Zoom Window and the second Zoom Window each time you click the Zoom button of a camera.
-

1. In the Content List, select **Layout**, click **Windows** and drag **Zoom Window** to a live view grid.
2. Move the mouse cursor to a camera live view and click **Zoom**  in the top-right corner. The camera live view is displayed in the Zoom Window.
3. To remove the camera from the Zoom window, place the cursor on the live view, click **Tools**  and select **Close**. To change the live view grid back to a normal window, repeat this step again to close the Zoom Window.

1.4.4 Setting a Scan Window

You can assign multiple cameras to a Scan Window, and each camera will be shown in sequence for the Scan Interval specified.

Note: Up to four Scan Windows can be created on each live view layout.

1. In the Content List, select **Layout**, select **Windows**, and drag **Scan Window** to a live view grid.
2. Drag multiple cameras into the Scan Window.

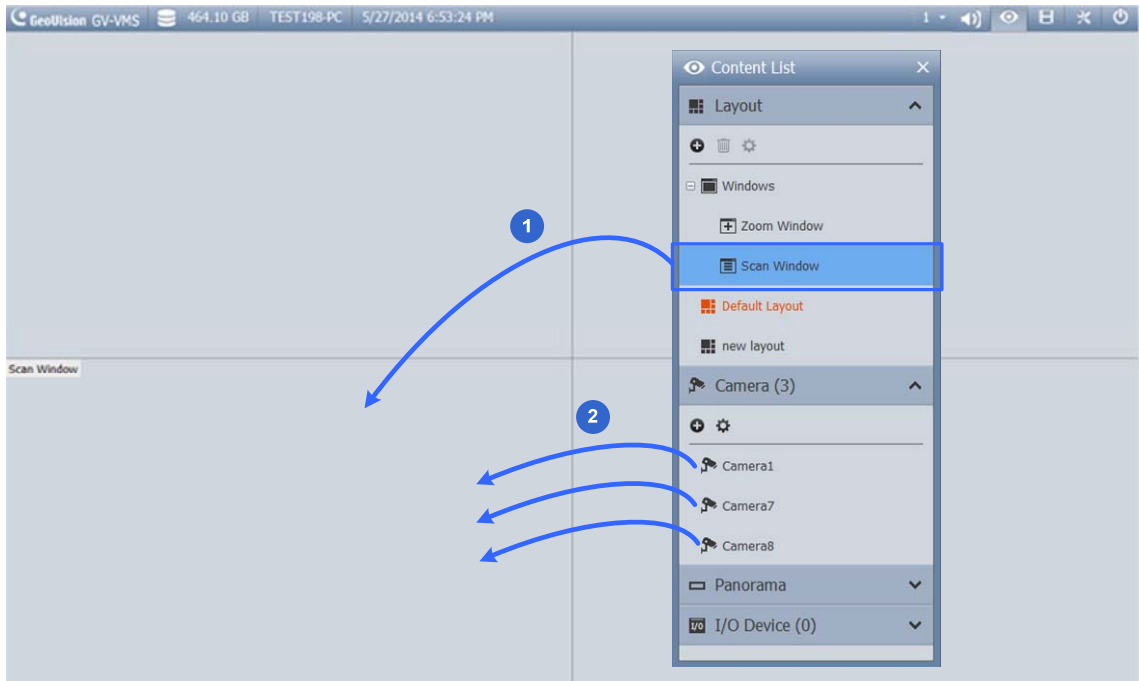

Figure 1-14

3. Move the cursor to the Scan Window, click **Tools** , and select **Properties**. This dialog box appears.

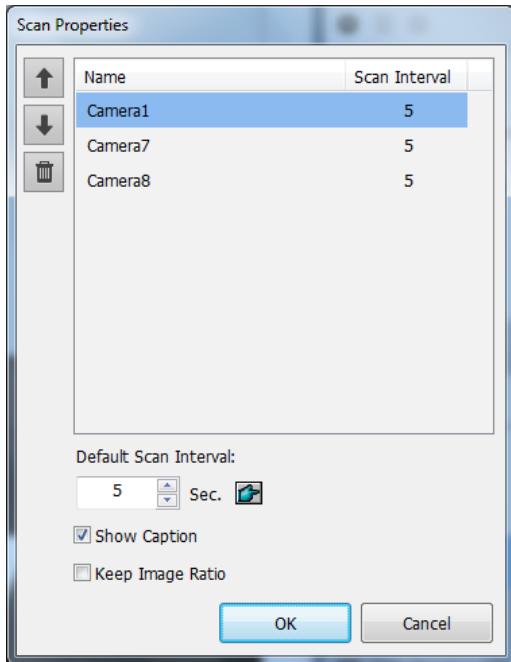



Figure 1-15

4. To adjust the order of a camera, select a camera and click the Up and Down arrows.

5. To specify how many seconds to show the live view of each camera, click and adjust the **Scan Interval** of each camera. Optionally click the **Finger**  to apply this Scan Interval to all cameras.
6. To show camera name on live view, select **Show Caption**.
7. To lock the original aspect ratio of the camera image, select **Keep Image Ratio**.
8. Click **OK**.



1.4.4.1 Creating a Camera Group

You can also add multiple cameras to a group and the created group can be dragged into a live view grid directly or Scan Window for display. At least 8 cameras are required in the camera list for this function to work.

1. Click **Camera** in the Content List, click **Add** , and click **Add Group**. Rename the group if necessary.
2. Drag the desired cameras from the camera list to the group created.
3. Drag the created group either into a live grid or Scan Window. For details on setting up a Scan Window, see *Setting a Scan Window* earlier in this chapter.

1.4.5 Setting a Popup Window

You can designate a Popup Window to display live images of cameras, upon events, on a separate monitor. For this function to work, you must first create a live view layout on another monitor.

1. In the Content List, click **Layout > Add**  **> Add Layout** to create a new layout.
2. After clicking **OK**, select a desired monitor from the **Apply to...** list to activate the layout on the designated monitor.
3. In the Content List, click **Windows > Add**  **> Add camera popup window** to select the cameras to be displayed in the Popup Window.
4. Rename the Popup Window if necessary and drag the Popup Window from the Content List to the layout created in Step 3.

1.4.6 Setting Focus View

You can create up to 7 close-up views per camera and place these created close-up views inside the live view grid.

1. In the Content List, right-click a camera and select **Focus View Setup**. This dialog box appears.

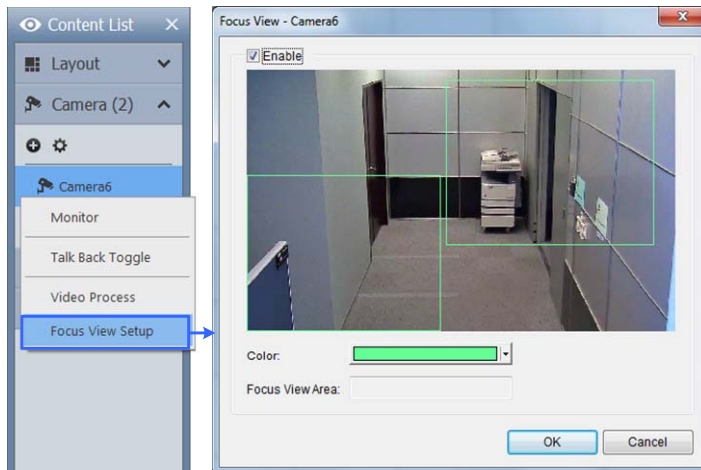

Figure 1-16

2. Click **Enable** and draw a box on the camera view to create a focus view. You can create multiple focus views if needed.
3. You can change the color of the box if needed.
4. Click **OK**. The created focus views are listed under the camera.
5. You can now drag the focus views to live view grids.

Note: This function is not supported for Fisheye Cameras and PTZ Cameras.

1.4.7 Automatic Switch among Different Live View Layouts

You can have different layouts automatically alternated at a specified interval.

1. Create and group several layout templates under the Content List (Figure 1-17).
2. Right-click the group to configure its **Scan Setting** to specify the scan interval.

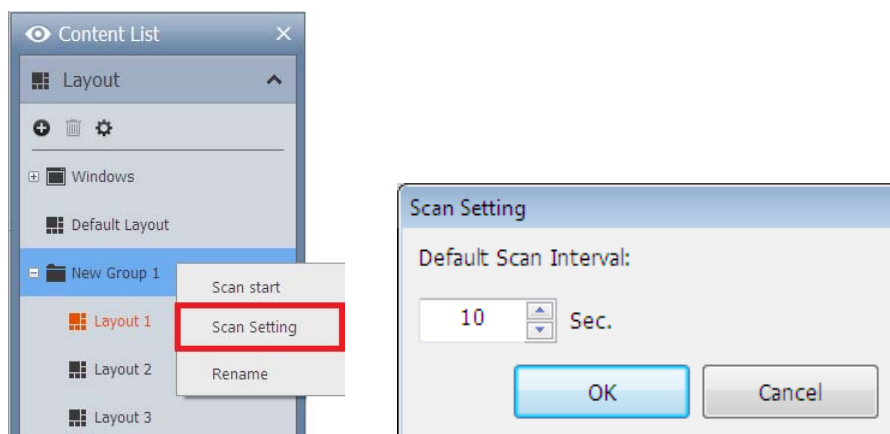

Figure 1-17

To start the automatic switch, right-click the group and select **Scan Start**. In the example above, Layout 1, Layout 2, and Layout 3 are automatically switched among each other every 10 seconds, with the currently displayed layout highlighted in orange.

1.4.8 Adding GV-IP Decoder Box for Remote Monitor Display

Only available on GV-VMS V18.1 or later, users can add GV-IP Decoder Box to the GV-VMS to be assigned the desired camera channels for remote monitor display. For details, see *Chapter 6 Integration to GV-VMS* in [GV-IP Decoder Box Ultra User's Manual](#).

1.5 Start Monitoring

After setting up the following functions, it is important to start monitoring in order for the functions to start: Recording, Video Analysis, Motion Event Trigger and Schedule.

To start monitoring, click **Home**  > **Toolbar**  > **Monitor**  and select one of the options:

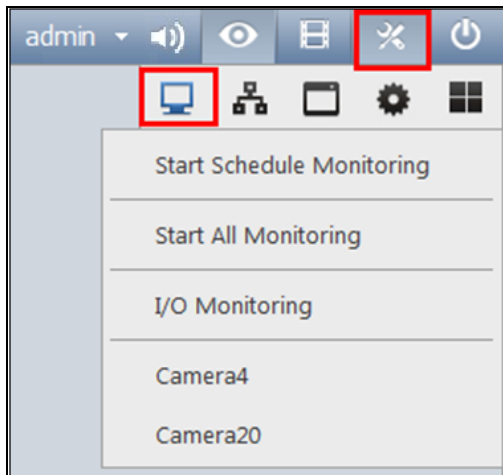

Figure 1-18



- **Start Schedule Monitoring:** If you want to start running a created schedule, select **Start Schedule Monitoring**. The schedule takes precedence over the current settings, and these functions will start and stop according to the schedule: Recording, Video Analysis, I/O, PTZ Auto Functions, Motion Event Trigger and Network Connections with Center V2 / Vital Sign Monitor. For details on creating a schedule, see *Schedule* later in this chapter.
- **Start All Monitoring:** Starts monitoring on all cameras to initiate recording and related functions.
- **I/O Monitoring:** Starts I/O monitoring to activate I/O functions. I/O Monitoring is only available after at least one I/O device is set up. For details on setting an I/O device on GV-VMS, see *Setting I/O Devices* in Chapter 6.
- **Camera#:** Starts monitoring of selected cameras. You can also start monitoring individual cameras by right-clicking the camera in the Content List and select **Monitor**.

Note: Motion detection and I/O trigger will only be registered in System Log if monitoring is started. You will also need to enable **Register Motion Event** in the Record Setting dialog box (Figure 1-10) and **Register Input Event** in the I/O Application Setting (Figure 6-10).

1.6 System Configuration

This section introduces system configurations of the GV-VMS.

1.6.1 Configuring General Settings

Start configuring **General Setting** by clicking **Home**  > **Toolbar**  > **Configure**  > **System Configure** > **General Setting**. This dialog box appears.

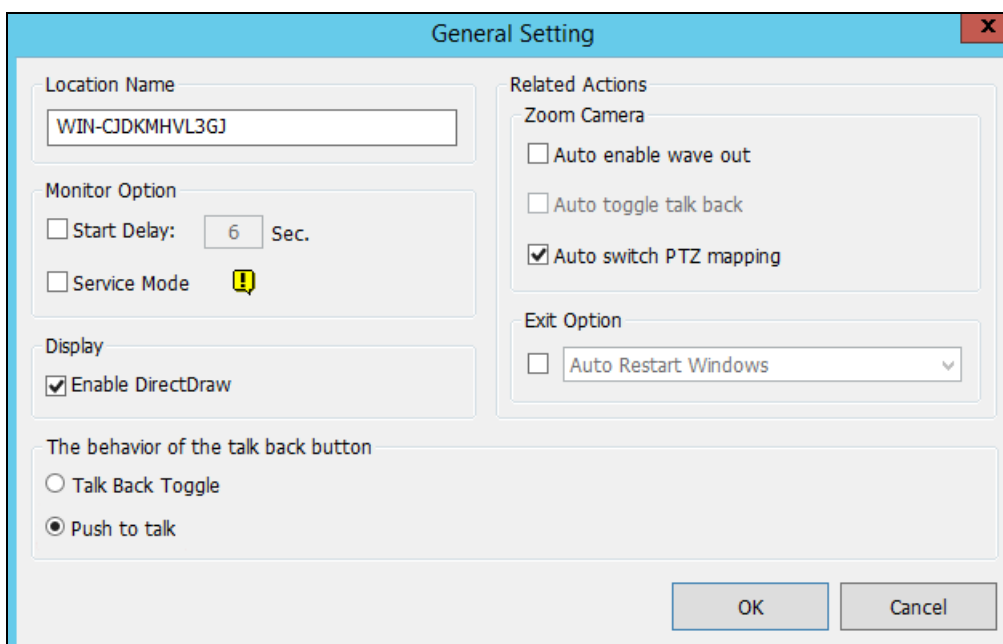

Figure 1-20

[Location Name] The given name (maximum 14 characters) is displayed in the main screen as the name of the server.

[Monitor Option]



- **Start Delay:** Start recording x second(s) after **Start All Monitoring** or **Start I/O Monitoring** is selected.
- **Service Mode:** Under Service Mode, GV-VMS can start automatically after system startup and run in the background without logging into Windows.

[Display]

- **Enable DirectDraw Scale:** Applies DirectDraw Scale to enhance image quality if it is supported by your VGA card. For certain VGA cards, DirectDraw Scale can result in blurred images. To avoid the image problem and maintain DirectDraw Scale, change the image quality to **Standard** [Video Setting] of the camera (Figure 2-11).

Note: The **Enable Directdraw Scale** function can greatly enhance image quality. Enable if your VGA card supports DirectX9. To check the version of your DirectX, click Start and run **dxdiag**. Open the file and find the related information.

[The behavior of the talk back button]

- **Talk Back Toggle:** Users can click the  button to talk to the surveillance site and click the button again to stop talking on the live view.
- **Push to talk:** Users can click and hold the  button to talk to the surveillance site and release the button to stop talking on the live view.



[Zoom Camera]

- **Auto enable wave out:** Automatically enables Wave Out function of the camera in Zoom Window or in full screen. Note that the Wave Out function needs to be enabled in the Audio Setting page of the camera first.
- **Auto toggle talk back:** Automatically enables Toggle Talk Back function of the camera. Note that the Toggle Talk Back function needs to be enabled in the Audio Setting page of the camera first.
- **Auto switch PTZ mapping:** This function only applies to GV-Keyboards that are connected to GV-VMS. When selected, PTZ control from the GV-Keyboard will be applied to the selected PTZ cameras. When not selected, the PTZ control buttons on GV-Keyboard will only be applied to the first available PTZ camera.

[Exit Option]

- **Auto Restart Windows:** Restarts Windows OS after exiting GV-VMS.
- **Auto Shut down Windows:** Shuts down Windows OS after exiting GV-VMS.

1.6.2 Customizing Startup Settings

To configure GV-VMS to enable certain features upon startup, click **Home**  > **Toolbar**  > **Configure**  > **System Configure** > **Startup**. This dialog box appears.

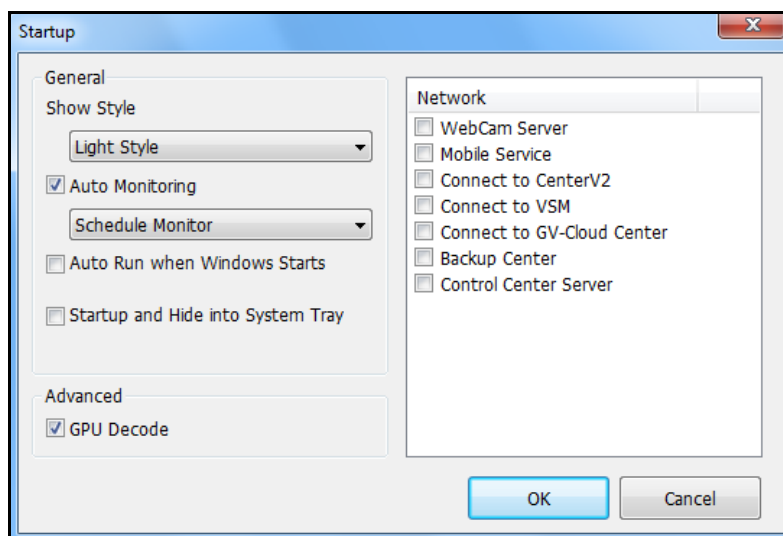
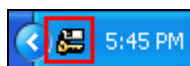

Figure 1-21

[General]

- **Show Style:** Change the color scheme of GV-VMS.
- **Auto Monitoring:** Select one of the following monitor control modes upon startup:
 - ⊙ **Monitor All:** Starts monitoring of all cameras and I/O (if available) upon system startup.
 - ⊙ **Schedule Monitor:** Starts monitoring of cameras by schedule. See *Schedule* later in this chapter.
 - ⊙ **I/O Monitor:** Starts monitoring of all I/O devices upon startup.
 - ⊙ **Camera Monitor:** Enables all cameras for monitoring.
- **Auto Run when Windows Starts:** Automatically runs GV-VMS after Windows starts. If you did not set an Auto Login account or an Auto Startup Login account, the Login dialog box will appear upon startup.
- **Startup and Hide into System Tray:** GV-VMS appears in the system tray when you launch Windows instead of displaying the system login window.



Note: **Startup and Hide into System Tray** and **Auto Startup Login** cannot function at the same time. When both are enabled, Auto Startup Login will not be applied. For details on Auto Startup Login, see *Setting a Startup Auto Login User* later in this chapter.



[Advanced]

- **GPU Decode:** GPU (Graphics Processing Unit) decoding can lower the CPU loading and increase the total frame rate supported by the GV-VMS. GPU decoding is enabled by default. But if your PC does not meet the system requirements as listed in the *Software Specifications* in *Important Notes*, you can disable this feature to optimize the system operations. After deselecting **GPU Decode**, restart GV-VMS for the change to take effect.

[Network]

- Automatically enables connection to the following application(s) upon startup: **WebCam Server, Mobile Service, Center V2, VSM, GV-Cloud Center, Backup Center, Control Center Server**

1.6.3 Customizing Display Position and Panel Resolution

You can customize the display settings of GV-VMS by clicking **Home**  > **Toolbar**  > **Configure**  > **System Configure** > **Set Position**. This dialog box appears. The right half is only available when multiple monitors are installed.

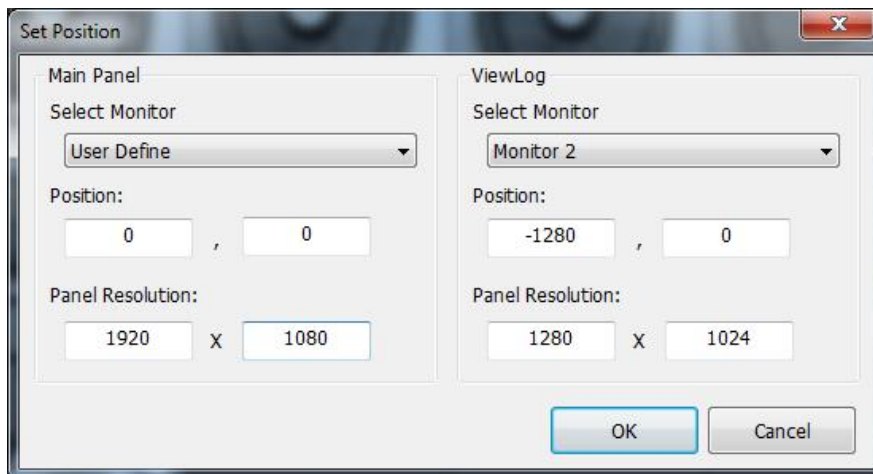

Figure 1-22

- **Select Monitor:** Select the monitor you want to configure from the drop-down list.

- Position:** Offsets the position of the GV-VMS window relative to the upper-left corner of the screen. The default position is 0, 0. A position of 100, 60 will place the GV-VMS window 100 pixels to the right and 60 pixels below the upper-left corner. This function is only supported when the GV-VMS window does not take up the entire screen.

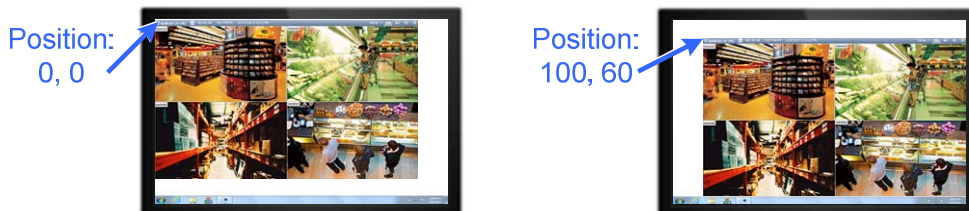





Figure 1-23

- Panel Resolution:** Sets the Panel Resolution of the GV-VMS.

1.6.4 Setting up E-mail Notification

Events that can be used to trigger e-mail notification include: Video Lost, Recording Error, Disk Full, Motion Detection, I/O Trigger, Intruder Event, Crowd Detection, Advanced Unattended Object, Advanced Scene Change Detection, Advanced Missing Object and Face Detection.

- To receive e-mail notification(s) upon the occurrence of an event, click **Home**  > **Toolbar**  > **Configure**  > **System Configure** > **Send Alerts Approach Setup**. The Alert Approach dialog box appears.
- To enable e-mail notification, select **Send Email** > **Email Setup**. This dialog box appears.

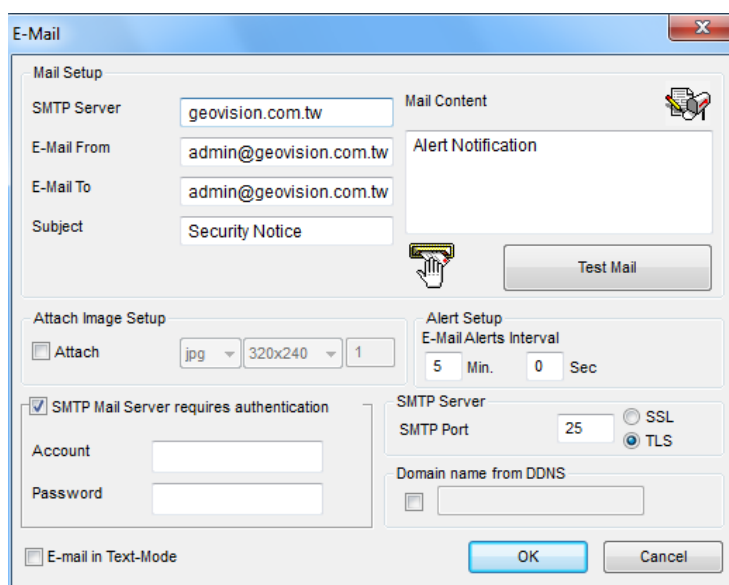





Figure 1-24

3. Under Mail Setup, type the host name of your outgoing mail server (SMTP), the sender's e-mail address, recipients' e-mail addresses and a subject for the e-mail notification. For For multiple recipients, add a semicolon between each e-mail address.
4. Click the **Test Mail** button to send a test e-mail and see whether the setup is correct. If the e-mail fails to send, you may need to check the following settings:
 - **SMTP Mail Server requires authentication:** If the SMTP mail server needs authentication for login, select this option and type your account name and password.
 - **SMTP Server:** Keep the default port 25 which is common for most SMTP servers. However webmail providers such as Gmail, Yahoo, and Hotmail generally use different SMTP port. In this case, check your e-mail provider for the SMTP port number. Select **SSL** or **TLS** if your e-mail server requires the SSL/TLS authentication for connection.
5. Complete other optional settings as needed:
 - **Mail Content:** Type the e-mail content that will be included in all e-mail notificaitons.
 - **Attach Image Setup:** Select **Attach** to include up to 6 snapshots in the e-mail. The image format and size are selectable. Note the actual size can be either the main stream or the sub stream depending on the On Demand setting. For details, see the *On Demand Display* section later in this chapter.
 - **Email-Alerts Interval:** Specify the time interval (0-60 seconds) between e-mail alerts to prevent e-mails from being sent too frequently. The default interval is 5 minutes.
 - **Domain Name from DDNS:** This option generates URL links for remote video playback in the sent e-mails. For this function to work, enter the fixed IP address or domain name of the GV-VMS and enable **WebCam Server**.
 - **E-mail in Text Mode:** When **WebCam Server** is enabled, your e-mail alert will be sent in HTML format. If you want to send the e-mail alert in pure text format, select this option.

Note: To enable WebCam Server, click **Home**  > **Toolbar**  > **Network**  > **WebCam Server**.

1.6.5 System Idle Protection

The System Idle Protection automatically log off and/or start monitoring after the GV-VMS is idle for a set period of time.

1. Click **Home**  > **Toolbar**  > **Configure**  > **System Configure** > **System Idle Protection Setting**. This dialog box appears.

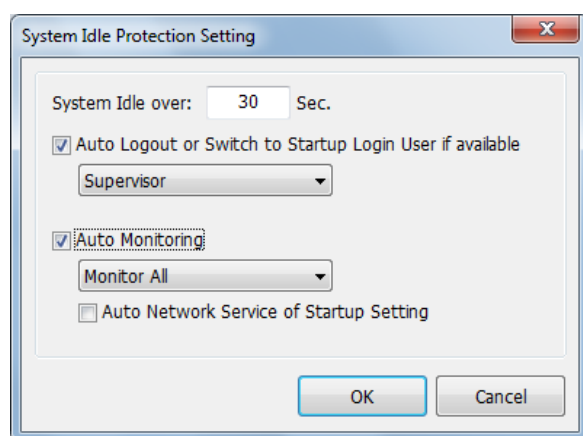





Figure 1-25

2. To automatically log out or switch to Startup Auto Login User, select **Auto Logout or Switch to Startup Login User if available** and select the type of account to log out from the drop-down list. If you have set up a Startup Auto Login User, GV-VMS will switch to the Startup Login User instead of logging out. For details, see *Setting a Startup Auto Login User* later in this chapter.
3. To automatically start monitoring, select **Auto Monitoring**, and use the drop-down list to select **Monitoring All**, **Schedule Monitoring**, **I/O Monitoring** or **Camera Monitoring**. When Monitoring All is selected, both I/O Monitoring and Camera Monitoring will be enabled.
 - Select **Auto Network Service of Startup Setting** to enable network connections to the applications predefined in Startup. See *Customizing Startup Settings* earlier in this chapter.
4. In the **System Idle Over** field, type an idle time between 10 and 14400 seconds.
5. Click **OK**.

Note: The feature can monitor keystrokes, mouse clicks and actions from IR Remote Control and GV-Keyboard.

1.6.6 Configuring Fast Key Lock

1. To enable/disable certain fast keys, click **Home**  > **Toolbar**  > **Configure**  > **System Configure** > **Fast Key Lock Setup**. The Fast Key Lock Setup dialog box appears.
2. Select one of the four tabs: General, ViewLog, PTZ Control and Network.
3. Clear the checkmark for the fast keys you want to disable. To restore the fast keys, select the checkbox again.
4. Click **OK** to apply your settings.

1.7 Account and Password

The password setup allows you to assign permission and rights to accounts. You can create up to **1,000** passwords. Only Supervisor-level accounts are pre-set with access to password settings. Click the account ID, click **Password Setup**, and select **Local Account Edit** to start.

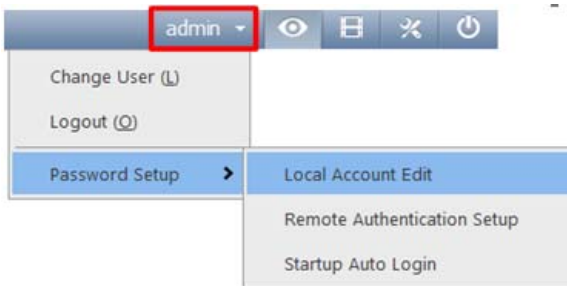

Figure 1-26

1.7.1 Creating an Account

To create a new account, click the **New** button at the lower-left hand corner of the Local Account Edit dialog box. You can create three types of accounts **Supervisor**, **Power User** and **User**.

- Supervisors have permissions over all system settings.
- Power Users have the same permissions as Supervisors, except that they cannot edit user accounts and delete the password system (described later).
- Users are restricted from all system settings and have limited access to certain functions.

If you want to enable the guest account, click **Guest** and deselect the **Disable Account** option. Guests will only be allowed to watch live view.

1.7.2 Configuring Account Settings

You may find these options to the right of the account list depending on the authorization level.

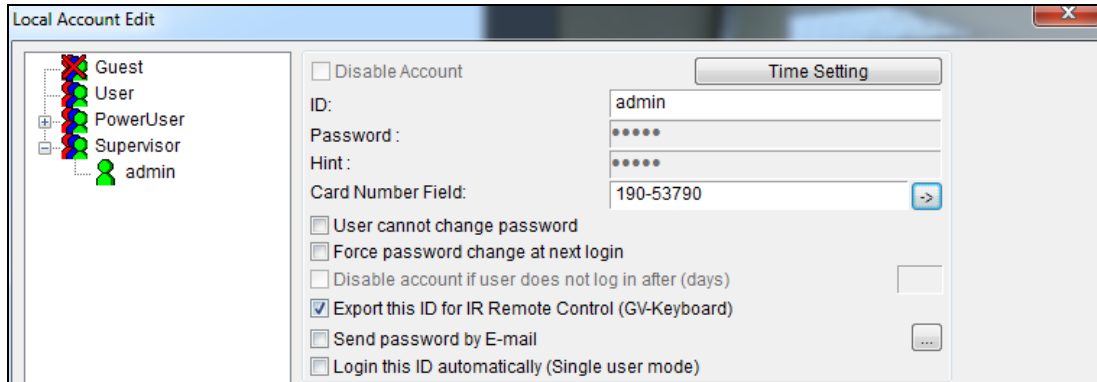



Figure 1-27

- **Disable Account:** Select if you want to disable this account.
- **Time Setting:** The account will expire and be disabled automatically after a set number of days. Click **Time Setting**, and select **Expire in (days)**. Specify the number between 1 and 9999. The number you set will count down automatically.
- **Card Number Field:** Users are allowed to automatically log into their accounts by inserting the card in the GV-PCR310 Enrollment Reader. Manually type your card number in the field, or insert your card in the GV-PCR310 Enrollment Reader and the card number will be shown in the field automatically. Click  to attach the card number to the user account.
- **User cannot change password:** The user is not allowed to change the set password.
- **Force password change at next login:** The user must change the password at next login.
- **Disable account if user does not login after xx day (s):** When the user does not log in the system after a set number of days, its account will be disabled automatically.
- **Export this ID for IR Remote Control:** Allows you to log into the system by using the GV-Keyboard instead of using the general keyboard and mouse. For details see *GV-Keyboard User's Manual*.
- **Send password by Email:** Allows you to retrieve passwords through e-mails. To specify e-mails, click the [...] button. See *Changing or Retrieving Password at Login* later in this chapter.
- **Login this ID automatically (Single User Mode):** GV-VMS will automatically log into this account after you click **Login** at startup.

At the bottom of the page are global settings, which are applied to all accounts.

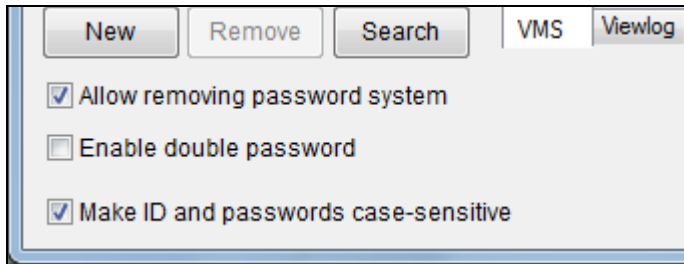

Figure 1-28

- **Allow removing password System:** Enables the password removal utility. The option is critical if you forget or are unable to retrieve any Supervisor password. With this option selected, you can run the password removal utility *PassUNINStall.exe* from the GV folder and remove the password database. Otherwise, you can only remove the password database by reinstalling Windows operating system.
- **Enable double password:** When selected, after starting ViewLog, you will need to type the passwords of any two supervisors to continue. At least 2 supervisor accounts are required.
- **Make ID and passwords case-sensitive:** Select to make all ID and passwords case-sensitive.

Note:

1. Before running the utility *PassUNINStall.exe*, you need to disable Service Mode on GV-VMS (Figure 1-21) and close GV-VMS. After running the utility, restart GV-VMS.
2. The loss of passwords can be solved in the following two ways:
 - Retrieving password through e-mails.
 - Removing password database by using the *PassUNINStall.exe* utility and rebuilding all accounts.

However, if both **Send Password by Email** and **Allow Removing Password System** options are not selected in advance, it is required to reinstall Windows operating system once you lose the passwords.

1.7.3 Changing or Retrieving Password at Login

You can change or retrieve passwords of GV-VMS through e-mail upon login.

Changing Password

1. In the Login dialog box, click **Change Password**. The Change Password dialog box appears.
2. Type the new password information, and click **OK** to save the changes.

Note: Only Supervisors can change the password.

Retrieving Password through E-mail

The password retrieval function works in the following ways after you click **Send Password** in the Login dialog box.

- If you are a supervisor but do not remember your ID, separate passwords will be sent to all supervisor e-mail accounts after you click the **Send Password** button.
- If you remember your ID but forgot your password, enter your ID and click **Send Password**. The password will be sent to your e-mail account.

1.7.4 Preventing Unauthorized System Termination

1. To restrict a non-supervisor account from exiting or restarting the system, click the account ID, click **Password Setup**, and select **Local Account Edit**. The Password Setup dialog box appears.
2. Select a user from the user list to display its properties.
3. Select the **VMS** tab at the bottom, and clear the **Exit System** option to restrict the user from quitting or restarting the system.

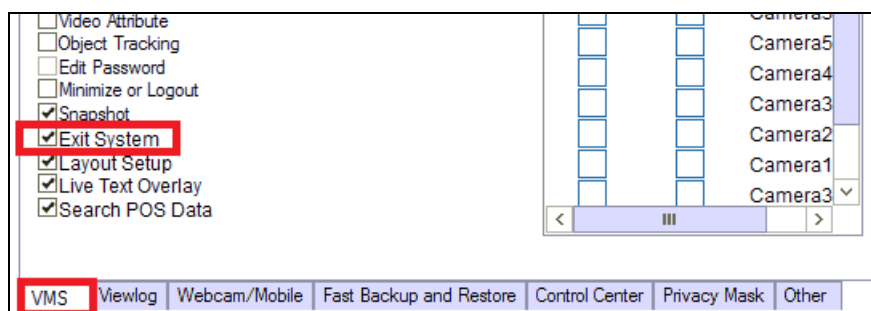

Figure 1-29

1.7.5 Setting a Startup Auto Login User

The Startup Auto Login User is typically a user account with limited access rights. After system is started, the GV-VMS will automatically log in with the Startup Auto Login User instead of showing the Login dialog box.

1. Create an account you want to use for Startup Auto Login. Refer to *Creating an Account* earlier in this section for instructions.
2. Click the account ID, click **Password Setup**, and select **Startup Auto Login**. Select **Startup Auto Login Setup**.
3. Type the ID and Password of the existing account you want to use.
4. Click **OK**.

If you have selected **Auto Logout** or **Switch to Startup Login User if available** in System Idle Protection Setting dialog box (Figure 1-25), GV-VMS will switch to the Auto Startup Login account after it is idle for the set period of time.

1.7.6 Setting Limits on Playback Time

1. To restrict playback time of camera channels, on the Local Account Edit dialog box, select an account, click the **ViewLog** tab, and click the playback time column you wish to configure.

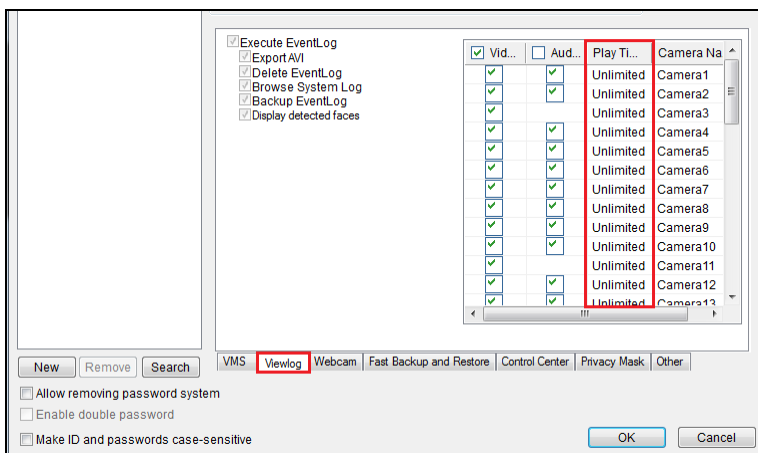



Figure 1-30

2. Select **Limited Playback Time** and specify a time limit. If you click , the time limit will be applied to other cameras.

Note: The Setting Limits on Playback Time is based on the time when the user logged into the account. To reset, please log out and log in again.

1.8 Schedule

You can create schedules to enable and disable the following functions at specific times of a day and apply the schedule to a weekly, monthly plan or a specific date.

- Recording
- Alert upon motion detection
- PTZ object tracking
- PTZ Auto functions
- Video Processing
- I/O monitoring
- Network connections to GV-Center V2, GV-Vital Sign Monitor, WebCam Server, Mobile Service and GV-Edge Recording Manager.

Click **Home**  > **Toolbar**  > **Configure**  > **Schedule Edit**. This dialog box appears.

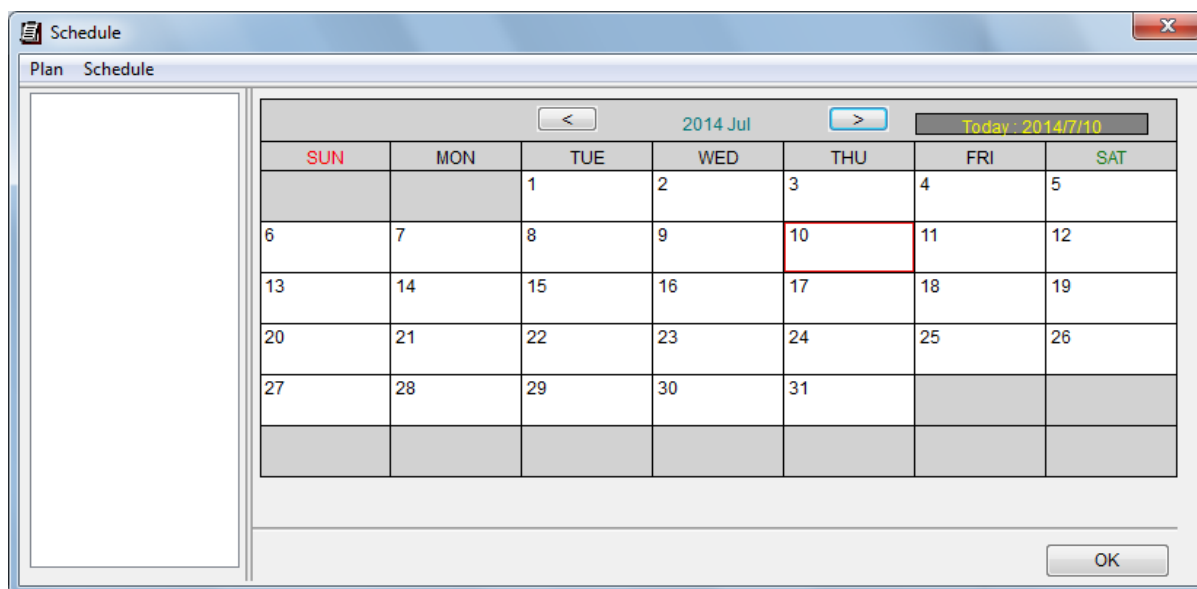

Figure 1-31

1.8.1 Creating a Schedule with Setup Wizard

The Setup Wizard is an easy way to create new schedule.

1. In the Schedule dialog box, click **Schedule** and select **Setup Wizard**.
2. Specify when to apply the schedule plan and click **Next**.
 - **Weekly:** Applies the schedule plan to the selected days each week.
 - **Special Day:** Applies the schedule plan to a specific date.
 - **Monthly:** Applies the schedule plan to a specific day each month.

Note: You can apply the schedule plan to additional days or modify the time settings later. After the schedule plan is created, refer to Step 3 in *Creating a Schedule Manually* later in this section.

3. Type a name for the schedule plan. If you have existing schedule plans, you can select **Use current plan** and apply the selected plan to different days.

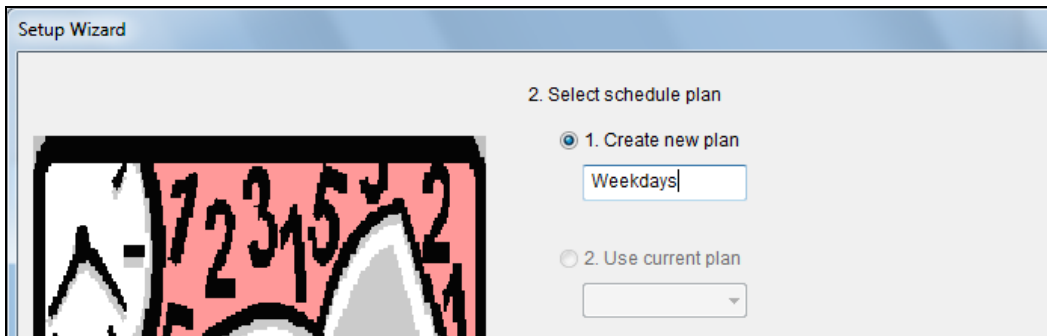

Figure 1-32

4. Click **Next**. This dialog box appears.

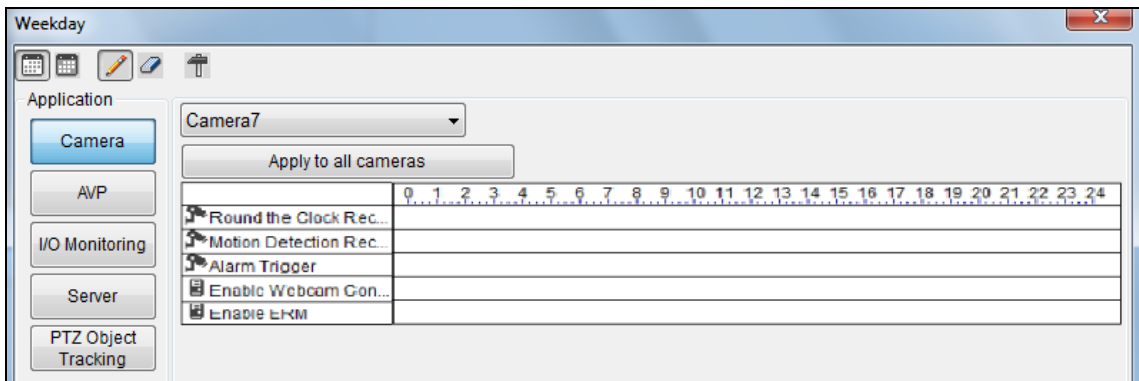









Figure 1-33

5. When the **Include** button  is selected, you will start with an empty timeline. Click the **Add** button  and drag across the timeline when you want the function to be enabled. Use the **Erase** button  when you want to disable the function.
6. You can also click the **Exclude** button  and start with everything disabled. The **Add** button  is now used for disabling the function instead and the **Erase** button  is now used for enabling the function.
7. Four categories are available on the left.
 - **Camera:**
 - ⊙ **Round-the-Clock Recording:** When highlighting the timeline, you can choose to apply the frame rate settings for **General Event** or **Urgent Event**. The settings here will override the settings in Record Setting once schedule monitoring is started. For information on General Event and Urgent Event, refer to *Configuring General Setting*, Chapter 2.
 - ⊙ **Motion Detection Recording:** When highlighting the timeline, you can apply different motion sensitivity levels. If you select **User Define**, the sensitivity level selected in Advanced Motion Detection Setup (Figure 1-8) will be used.
 - ⊙ **Alarm Trigger:** The Event Trigger methods selected in Advanced Motion Detection Setup (Figure 1-8) will be triggered upon motion during the highlighted times.
 - ⊙ **PTZ:** When highlighting the timeline, you can select a PTZ Auto function to be enabled during that time. At least one PTZ camera is required.
 - ⊙ **Enable Webcam Connection:** Grants streaming access for WebCam Server for the camera channel within the time periods highlighted.
 - ⊙ **Enable ERM Server:** Grants streaming access for Edge Recording Manager for the camera channel within the time periods highlighted.

Note: Enable Webcam Connection and Enable ERM Server are only available on GV-VMS V18.1 or later.

- **AVP:** During the enabled times, the selected video processing functions will be enabled even if the cameras are not recording.
 - **I/O Monitoring:** Enables I/O Monitoring.
 - **Server:** Enables network connections to Center V2, Vital Sign Monitor, WebCam Server, Mobile Service and/or ERM Service.
8. To apply the Camera and AVP schedules to selected cameras, use the camera drop-down list above the timeline or click the **Advanced Setting** button .

- Click **OK**. The schedule plan created appears on the days you specified.

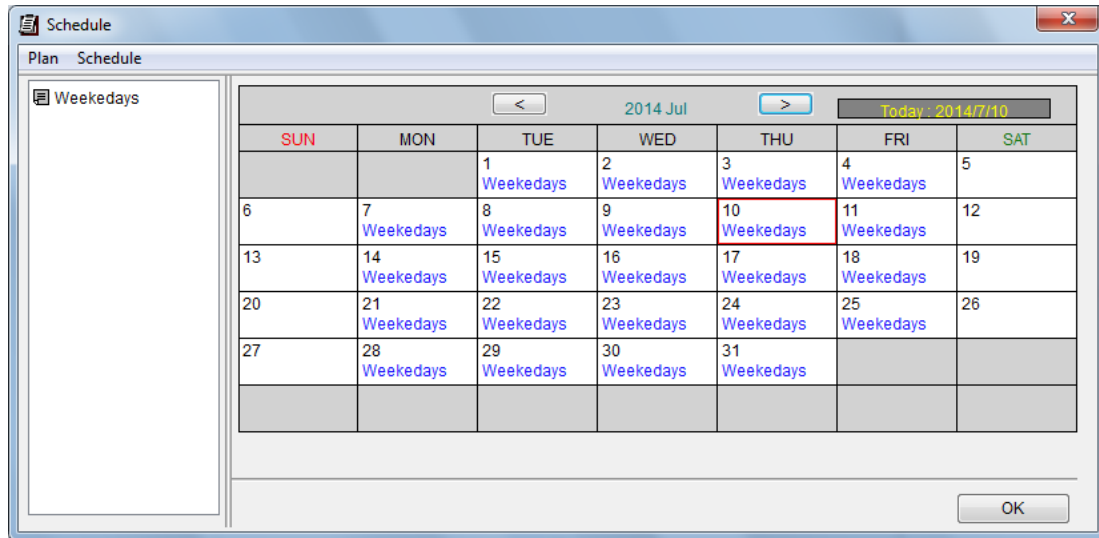

Figure 1-34

Tip:

- You can drag the created plan on the left of the Schedule dialog box to the calendar on the right and the plan will be applied to the date.
- To edit the schedule timeline, simply double-click the plan in the calendar.

1.8.2 Creating a Schedule Manually

- In the Schedule dialog box, click **Plan** and click **Add**.
- Type a name for the plan and click **OK**.
- Click **Schedule** and select an option below:
 - **Edit Special Day:** Applies the schedule plan to a specific date each year. Select a **Date** and a **Plan** and click the **Add** button.
 - **Edit Weekly:** Applies the schedule plan to the selected days each week.
 - **Edit Monthly:** Applies the schedule plan to a specific date each month. Select a **Day** of the month and a **Plan**, and click the **Add** button.
- Double-click the Plan to edit the schedule timeline. Refer to *Creating a Schedule with Setup Wizard* earlier in this section for details.

1.8.3 Exporting and Importing Schedule Settings



Schedule settings can be exported into an .xml file, and imported back later or to another GV-VMS.

1. In the Schedule dialog box, click **Schedule** and click **Export** or **Import**. A dialog box appears.
2. Specify the path to save the .xml file. Or, specify where the exported .xml file has been stored.
3. Click **OK**.

1.9 System Log

System Log provides historical information that can help you track events, system problems and object counting data.

1.9.1 Setting System Log

In System Log Setting, you can specify which events to record, the interval time to write the event into the system, and the number of days to keep the logs for. Click **ViewLog**  > **Toolbar**  > **Configure**  > **System Log Setting**. This dialog box appears.

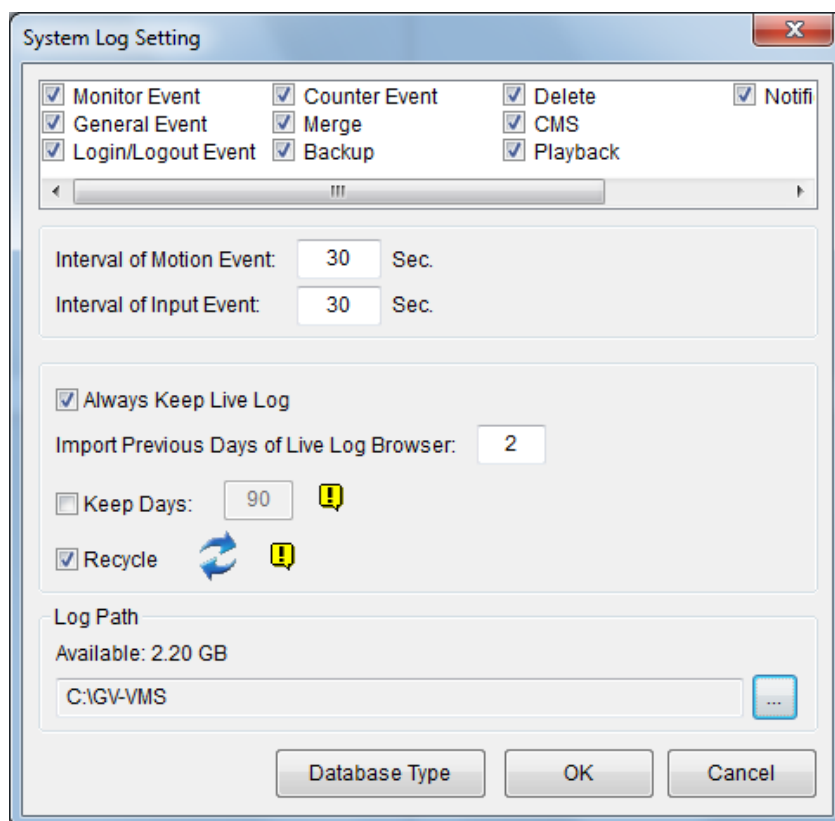

Figure 1-35

Select the types of event to register in System Log:

- **Monitor Event:** Registers motion-triggered and I/O-triggered events. For this feature to work, you must enable the **Register Motion Event** option in Figure 1-10 or the **Register Input Event** option in Figure 6-10.
- **General Event:** Registers system startup/exit, network server start/stop, and monitoring start/stop.
- **Login/Logout Event:** Registers login/logout activities of local users to GV-VMS and WebCam Server.
- **Counter Event:** Registers counting results.
- **Merge:** Registers merging of recorded videos.
- **Backup:** Registers backing up of recorded videos.
- **Delete:** Registers deletion of recorded videos through remote connection.
- **CMS:** Registers CMS related events.
- **Playback:** Registers playback of recorded videos.
- **Notification:** Registers email notifications.

The following settings are also available:

- **Interval of Motion Event:** Specifies the log interval between motion-triggered events. This setting could prevent the System Log from becoming too large in a motion-intensive environment.
- **Interval of Input Event:** Specifies the log interval between I/O-triggered events.
- **Always Keep Live Log:** When selected, the current log will be displayed in system log. When not selected, system log of the time selected in ViewLog timeline will be displayed if available.
- **Import Previous Days of Live Log Browser:** Specifies how many days of data to be loaded into the System Log.
- **Keep Days:** Set the number of days to keep the logs.
- **Recycle:** Enable the system to delete old log files to make space for newer files when the space of assigned Log Path is below 500 MB.
- **Log Path:** Click the ... button to specify a storage path. The default log path is :\\GV folder\\. The available free space of the storage path will be displayed above.
- **Database Type:** To choose how to save your system database, select **Microsoft Office Access Database** or select **Microsoft SQL Server** and fill out the required fields

1.9.2 Viewing System Log

To view the System Log, click **ViewLog**  > **Toolbar**  > **Tools**  > **System Log**. The following options are available: Monitor Table, CMS Table, and Advanced.

Monitor Table

Local events on GV-VMS are displayed.

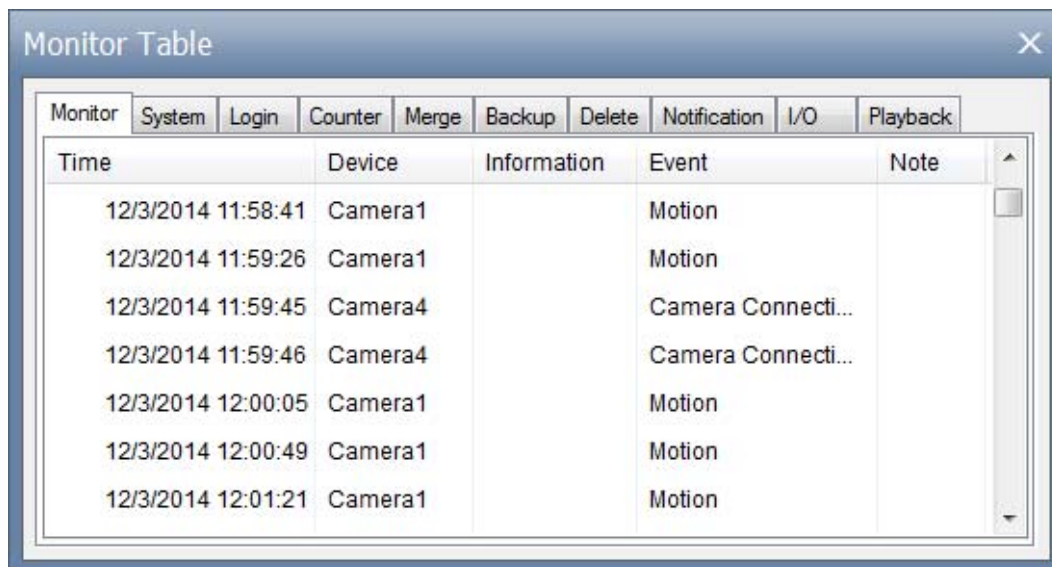

Monitor	System	Login	Counter	Merge	Backup	Delete	Notification	I/O	Playback
Time	Device	Information	Event	Note					
12/3/2014 11:58:41	Camera1		Motion						
12/3/2014 11:59:26	Camera1		Motion						
12/3/2014 11:59:45	Camera4		Camera Connecti...						
12/3/2014 11:59:46	Camera4		Camera Connecti...						
12/3/2014 12:00:05	Camera1		Motion						
12/3/2014 12:00:49	Camera1		Motion						
12/3/2014 12:01:21	Camera1		Motion						

Figure 1-36

[Monitor] Shows events related to camera connection and motion. Double-clicking an event will allow you to view the related video (if available) in ViewLog.

[System] Shows system startup/exit, network server start/stop, and monitoring start/stop.

[Login] Shows whom and when has logged in and out of GV-VMS and WebCam server.

[Counter] Shows the information and results of GV-VMS's counter functions.

[Merge] Shows the merging events of recorded videos.

[Backup] Shows the backup events of recorded videos.

[Delete] Shows the deletion of recorded videos through remote connection.

[Notification] Shows email notifications.

[I/O] Shows the events related to I/O trigger.

[Playback] Shows the playback of recorded videos.

CMS Table

CMS Table shows the connection status, login activities and service start related to CMS.

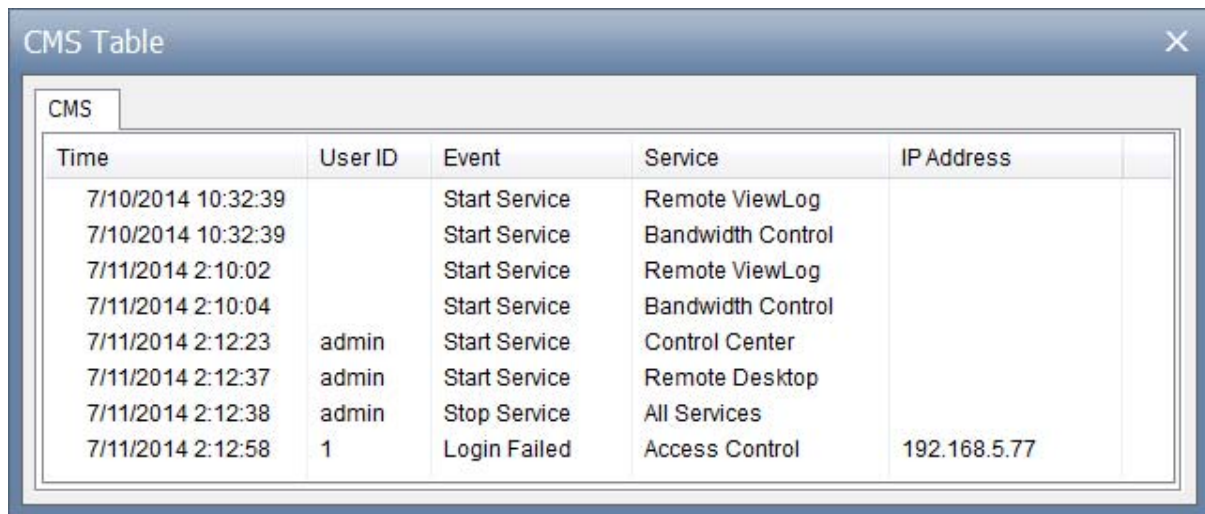

The screenshot shows a window titled "CMS Table" with a close button in the top right corner. Inside the window, there is a tab labeled "CMS" and a table with the following data:

Time	User ID	Event	Service	IP Address
7/10/2014 10:32:39		Start Service	Remote ViewLog	
7/10/2014 10:32:39		Start Service	Bandwidth Control	
7/11/2014 2:10:02		Start Service	Remote ViewLog	
7/11/2014 2:10:04		Start Service	Bandwidth Control	
7/11/2014 2:12:23	admin	Start Service	Control Center	
7/11/2014 2:12:37	admin	Start Service	Remote Desktop	
7/11/2014 2:12:38	admin	Stop Service	All Services	
7/11/2014 2:12:58	1	Login Failed	Access Control	192.168.5.77



Figure 1-37

Advanced Log Browser

See *Advanced Log Browser* in Chapter 4.

1.10 Other Functions

1.10.1 Setting Pop-up Live View

To set up pop-up live view, which overlays the entire main screen, upon events, click **Home**  > **Toolbar**  > **Configure**  > **Camera Popup Setting**. This dialog box appears.

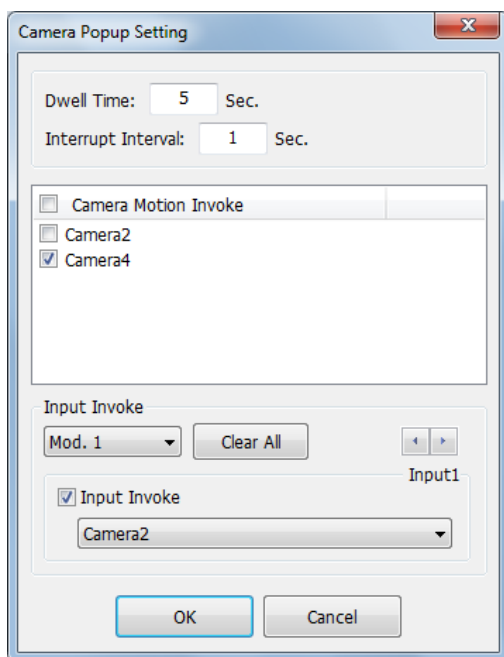

Figure 1-38

- **Dwell Time:** Specify the amount of time a pop-up live video to remain in the foreground.
- **Interrupt Interval:** Specify the interval between live video pop-ups. This feature is useful when several cameras are activated for a pop-up alert at the same time.
- **Camera Motion Invoke:** Select the camera to enable auto pop-up upon motion detection. Monitoring of the camera is required.
- **Input Invoke:** Select an input module using the drop-down list and select the input number using the arrow buttons. Select **Input Invoke** and assign a camera to the input device. Whenever the input is triggered, the live video of the assigned camera will pop up. I/O monitoring is required.

Note: You can use the **Mask Region** function in the Advanced Motion Detection Setup dialog box (Figure 1-8) to mask off certain areas of the camera image that you don't want to detect motion.

1.10.2 Adjusting to Daylight Saving Time

GV-VMS can automatically adjust to Daylight Saving Time (DST). If you are in a time zone that uses DST, make sure DST is enabled. In Windows' Control Panel, go to **Date and Time**, click **Change Time Zone**, and make sure **Automatically adjust clock for Daylight Saving Time** is selected.

In System Log, DST events are labeled with clock icons ⌚ in the **Time** column.

Monitor	System	Login	Counter	Merge	Backup	Delete	Notification	I/O	Playback
Time	Device	Information	Event	Note					
⌚ 11/1/2015 1:06:48	Camera 14		Motion						
⌚ 11/1/2015 1:06:50	Camera 14		Motion						
⌚ 11/1/2015 1:06:58	Camera 14		Motion						

Figure 1-39

In ViewLog, click the **Camera Date Viewer** and click **Search Event in DST**.

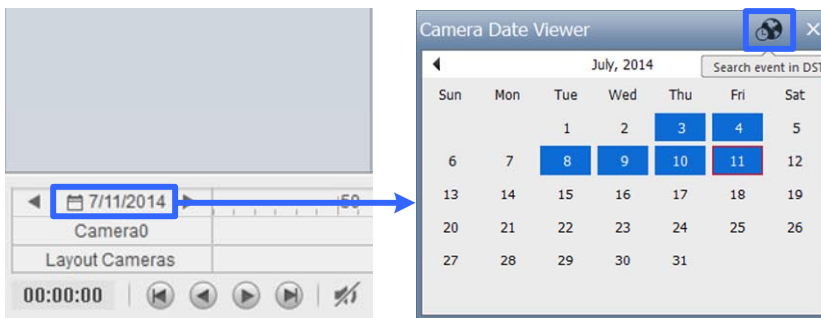





Figure 1-40

Note: Videos recorded during DST periods start with "GvDST", e.g. GvDST20140722.avi, to differentiate from regular video files that start with "Event", e.g. Event20081022.avi.

1.10.3 Setting Network Failure Detection

The Network Failure Detection function triggers an output device when the network connection between GV-VMS and the specified network host has failed.

1. Click **Home**  > **Toolbar**  > **Network**  > **Network Failure Detection**. This dialog box appears.

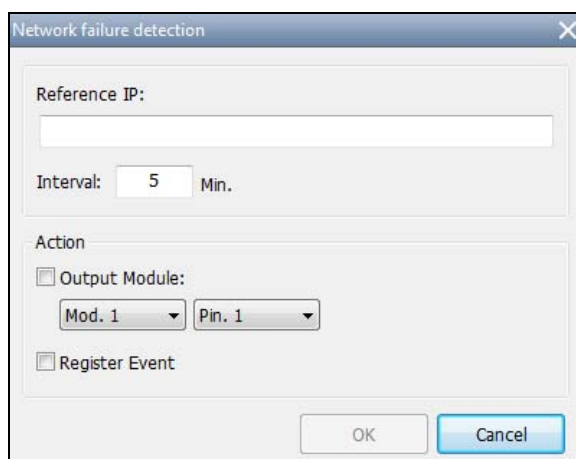



Figure 1-41

2. Under **IP Address**, type the IP address or domain name of the remote host.
3. Next to **Interval**, type the time interval between each ping in minutes ranging from 1 to 999. If the interval is 5 minutes, GV-VMS will ping the network host every 5 minutes to check if the connection is still active.
4. Under Action, enable **Output Module** and select the output module and pin number.
5. Enable **Register Event** to record the error to System Log.
6. Click **OK**.

The selected output device will be triggered when the network host does not respond to GV-VMS's ping message.

1.11 PTZ Camera

With the PTZ control panel, you can control PTZ functions, e.g. pan, tilt, zoom, focus and preset points.

1. Move the cursor to the camera live view of a connected PTZ camera and click **Tools** .

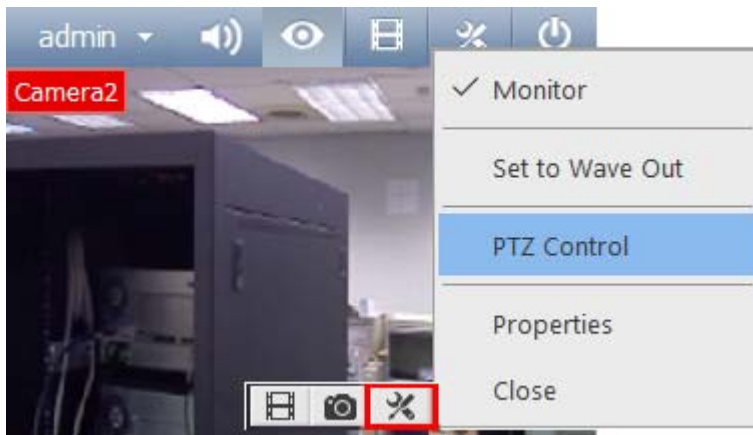

Figure 1-42

2. Click **PTZ Control** to enable PTZ function.
3. You can control GV-IP Speed Domes using the following actions:
 - **Double-Click:** The camera will center on the spot you clicked.
 - **Drag:** You can select Random Move or Center Move after right-clicking the live view.
 - ⊙ **Random Move:** Drag a line on the live view and the camera will move toward the direction you dragged.
 - ⊙ **Center Move:** Drag a box on the live view and the camera will zoom in on the area you dragged.

1.11.1 Accessing PTZ Control Panel and Auto Functions

After PTZ Control is enabled, move the cursor to the live view to see the PTZ control panel. Note that the PTZ control panel is hidden when live view resolution is less than 240 x 180.

Note: From GV-VMS V16.10.3, ONVIF PTZ cameras no longer supports Iris Open / Close function on the PTZ control panel.

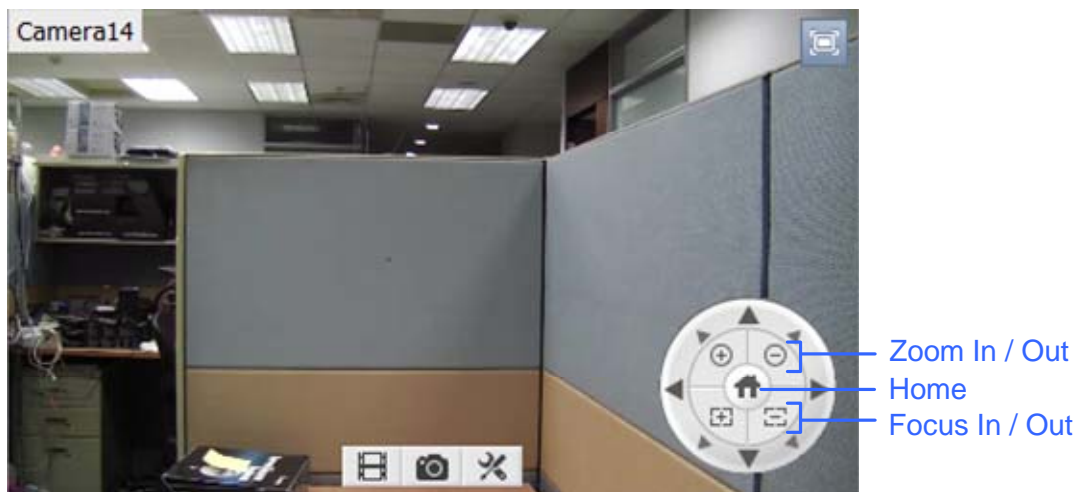





Figure 1-43



In the PTZ control panel, click **Home**  to access the advanced PTZ functions below. The options available may differ depending on the model of your PTZ camera.

- **Home:** Returns the camera to Home position.
- **Iris Open / Close:** Adjusts the camera iris. The iris Control buttons are only available for GV-IP Speed Dome.
- **Auto Focus:** Adjusts the camera focus according to the subject.
- **Auto Iris:** Adjusts the iris opening according to amount of light in the environment.
- **Auto Go:** Allows you to enable Cruise, AutoPan, Sequence and Tour functions. You can click **Stop Auto Go** to stop the Auto function you have enabled.
- **Auto Set:** Allows you to set up AutoPan and Cruise functions. See the section below for details.
- **Preset Go:** Moves the PTZ to a preset point by clicking the preset number.
- **Preset Set:** Allows you to configure up to 256 PTZ preset points. Move the camera to the position where you want set a preset point and then select a preset point number here.

Auto Pan



The PTZ camera will continuously move between two horizontal positions. You can configure up to 8 sets of Auto Pan mode.

1. Move the camera to the start position of the AutoPan.
2. To mark the start position, click the **Home** button  in the PTZ Control Panel, select **Auto Set**, and select **Start AutoPan1**.
3. Move the camera to the end position of the AutoPan. Any movement in the vertical direction will not be included in the AutoPan.
4. To mark the end position, click the **Home** button , select **Auto Set**, and select **End AutoPan1**.
5. To create another Auto Pan mode, repeat the steps above using a different Auto Pan number.

To enable the AutoPan, click the **Home** button , select **Auto Go**, and select the AutoPan number created. To stop the AutoPan, simply click a Pan/Tilt button in the PTZ Control Panel to interrupt the AutoPan, or you can click the **Home** button , select **Auto Go**, and select **Stop Auto Go Function**.

Cruise

You can set up a route consisting of different directions, angles, and zooms for the PTZ camera to follow. Up to 4 Cruises can be created.

1. Move the camera to the start position of the Cruise.
2. To mark the start position, click the **Home** button  in the PTZ Control Panel, select **Auto Set**, and select **Set Cruise 1**.
3. Move the camera according to how you want the camera to move during the Cruise. The camera positions, zooms, and speed of the movement will all be recorded for the Cruise. .
4. When you are finished with setting up the Cruise, click the **Home** button , select **Auto Set**, and select **Set Cruise Stop**.
5. To set up another Cruise route, repeat the steps above and select a different Cruise number.

To enable the Cruise route, click the **Home** button , select **Auto Go**, and select the Cruise number created. To stop the Cruise route, simply click a Pan/Tilt button in the PTZ Control Panel to interrupt the Cruise function, or you can click the **Home** button , select **Auto Go**, and select **Stop Auto Go Function**.

1.11.2 Setting PTZ Idle Protection and Advanced Functions

In the Content List, right-click the PTZ camera and select **PTZ Setup**. This dialog box appears.

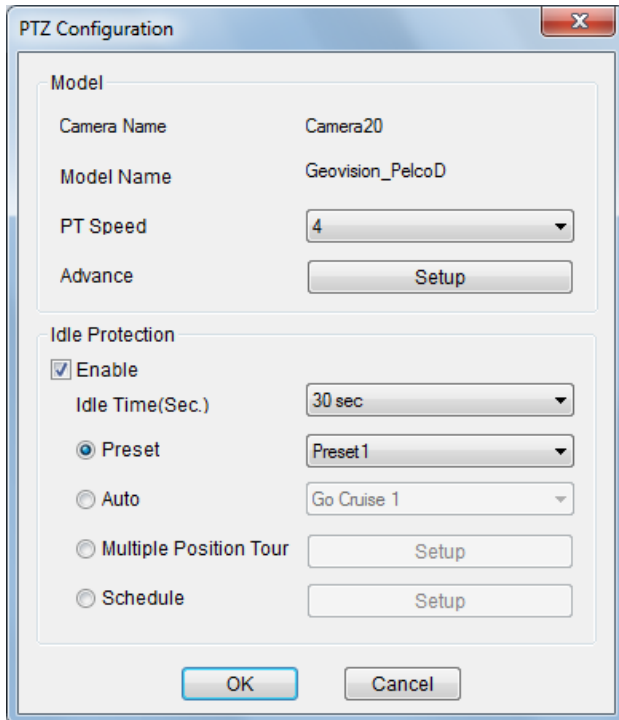

Figure 1-44

- **PT Speed:** Adjusts the speed of pan and tilt movements.
- **Advanced:** Click **Setup** to access advanced functions, such as image attributes, sequence, tour and Home position. Consult the manual of the connected PTZ model for details.

[Idle Protection]

When the PTZ camera remains stationary for a certain period of time, the PTZ can automatically move to a Preset Point, enable an Auto function, begin a Multi Position Tour or start the PTZ schedule.

1. Click **Enable**.
2. Set the **Idle Time**. The PTZ camera will follow the action selected in the next step after the idle time exceeds the specified Idle Time.
3. Select **Preset**, **Auto**, **Multi Position Tour** or **Schedule** as protection mode. See *Setting Multi Position Tour* below.
4. Click **OK**.

Setting Multi Position Tour

You can create a PTZ tour with up to 64 preset points. Note the number of preset points depends on your PTZ capacity.

1. Select **Multi Position Tour** in the PTZ Configuration dialog box, and click the **Setup** button. This dialog box appears.

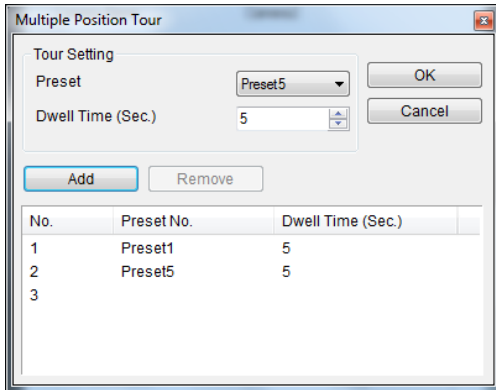

Figure 1-45

2. Select a **Preset** as a starting point.
3. Set the **Dwell Time** that the PTZ will remain at each preset point.
4. Click **Add** and repeat Steps 2-3 to build more points in the tour.

1.12 QView

If there are multiple monitors connected, you can use the QView feature to display full-screen live view of a camera on a separate monitor.

1. Click **Home**  > **Toolbar**  > **Configure**  > **System Configure** > **Set Position**. This dialog box appears.

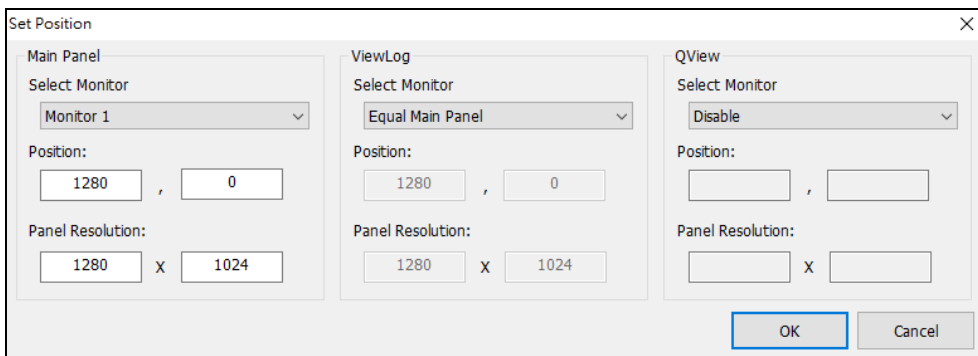

Figure 1-46

2. In the QView section, select a desired monitor from the **Select Monitor** drop-down list to open a full-monitor display and click **OK**.
3. Double-click a camera view on the live view grid. The camera view is now displayed in full screen on the designated monitor.
4. To switch another live view to a full-monitor display, simply double-click another camera view.



To record short video clips on a full-monitor display, see *Creating a Storyline in QView* later in this chapter.

1.13 Storyline

With the Storyline feature, you can combine camera images from multiple channels into a sequence of short video clips of a specific incident, such as gambling fraud, shoplifting and other fraudulent activities. The recorded videos can be saved and played back later using a media player. This feature is available in live view, video playback and QView display.

1.13.1 Creating a Storyline in Live View

You need to drag the Zoom Window to a live view grid before the storyline feature can be enabled. Any channel image on the Zoom Window will be recorded as a storyline.

1. Set up the screen division with the channel images of interest.
2. In the Content List, select **Layout**, click **Windows** and drag **Zoom Window** to a live view grid.
3. To display a live view on the Zoom Window for recording, move the mouse cursor to a camera live view and click the **Zoom** button  in the top-right corner.
4. Click the **Tools** icon  and select **Storyline** to start recording. The orange label indicates that the recording is in progress.

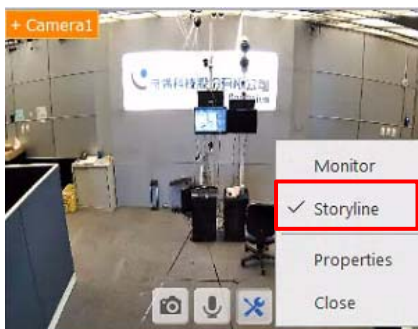

Figure 1-47

5. To record from another live view source, click the **Zoom** button of that live view grid in the top-right corner.
6. When you finish, deselect **Storyline** to stop recording. The Edit Description dialog box appears.
7. Type a name or description for the video clip and click **OK**.

Note:

1. The maximum recording length is limited to 30 minutes per storyline.
2. The resolutions of recorded storylines are 1280 x 1024 (default) and 1920 x 1080. To change the resolution: Toolbar > Configure > System Configure > Record Setting

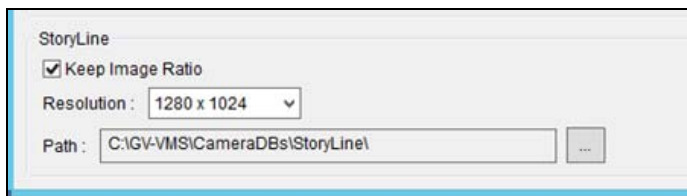







Figure 1-48

1.13.2 Creating a Storyline in Video Playback



The procedures of creating a storyline with playback videos are similar to those for live view images.

1. Click **ViewLog**  > **Toolbar**  > **Content List**  and drag **Zoom Window** onto the playback grid.
2. To display a video on the Zoom Window, move the cursor to the recorded video and click the **Zoom** button  in the top-right corner.
3. Right-click the playback screen or click the **Tools** icon , and select **Storyline** to start recording.
4. To record another video, click the **Zoom** button of the playback screen in the top-right corner.

1.13.3 Creating a Storyline in QView

1. Follow the instructions in QView earlier in this chapter to set up a full-monitor display.
2. On the designated monitor, click **Tools**  and select **Storyline** to start recording.
3. To record the live video from another camera, simply double-click another camera live view.

1.13.4 Accessing the Storyline

After creating the storyline, select **ViewLog**  > **Toolbar**  > **Tools**  > **Story Line**. Your storyline will be listed in the window below.

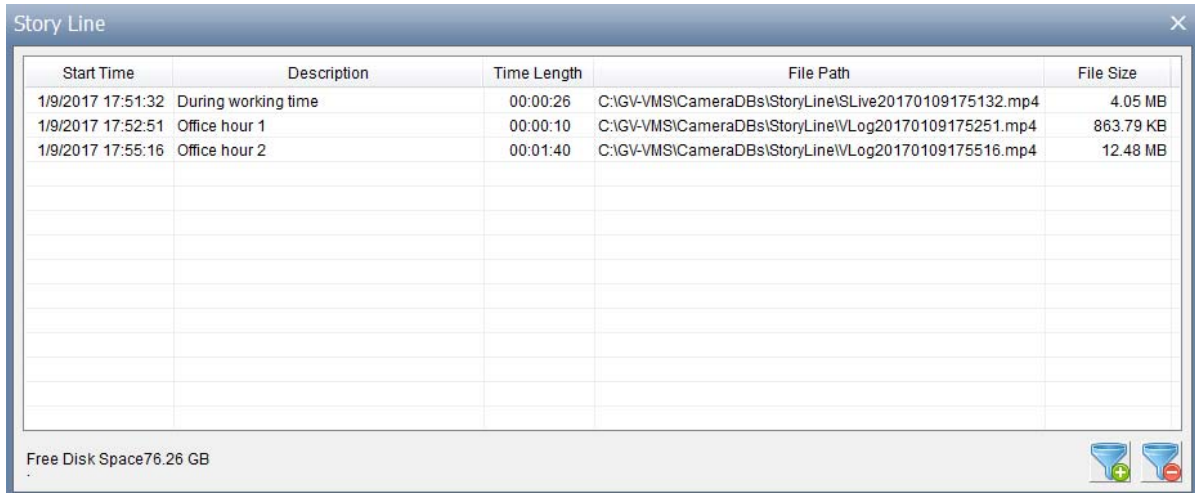



Start Time	Description	Time Length	File Path	File Size
1/9/2017 17:51:32	During working time	00:00:26	C:\GV-VMS\CameraDBs\StoryLine\SLive20170109175132.mp4	4.05 MB
1/9/2017 17:52:51	Office hour 1	00:00:10	C:\GV-VMS\CameraDBs\StoryLine\WLog20170109175251.mp4	863.79 KB
1/9/2017 17:55:16	Office hour 2	00:01:40	C:\GV-VMS\CameraDBs\StoryLine\WLog20170109175516.mp4	12.48 MB

Free Disk Space 76.26 GB

Figure 1-49

Right-click a storyline on the list to access more features, such as playback, changing the file path and editing the description. You can also use the **Filter** button  to search for the desired storylines.

1.14 GV-VR360 Dewarped View

GV-VMS provides two dewarped modes for [GV-VR360](#) under Content List (**Home**  > **Toolbar**  > **Content List** ).

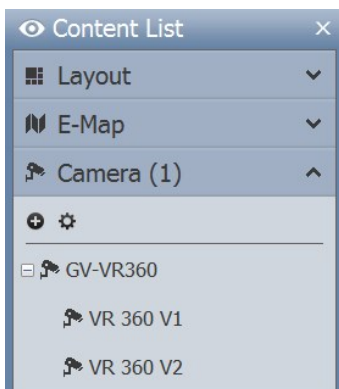





Figure 1-50

- **GV-VR360:** The undewarped image of the GV-VR360.
- **VR 360 V1:** A dewarped mode of the GV-VR360 that allows manual control to view all angles of the image. Click and hold on the image to adjust the angle of view and click  to zoom in.
- **VR 360 V2:** A dewarped mode of the GV-VR360 that automatically pans around the image 360° endlessly. Click  or  to adjust the speed of the auto pan and click  to zoom in.

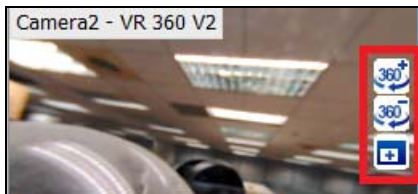

Figure 1-51

Note:



1. To view the dewarped image of GV-VR360 on GV-VMS, the graphic card must support DirectX 10.1 or above.
 2. Up to 2 GV-VR360 can be connected to a GV-VMS with a total frame rate of 24 fps.
-

Chapter 2

IP Camera Setup	64
2.1 Adding IP Cameras	64
2.1.1 Adding Cameras Manually	65
2.1.2 Scanning for Cameras	67
2.1.3 Mapping GV-IP Cameras using GV-IP Device Utility	67
2.1.4 Adding Cameras of Mobile Devices using GV-Live Streaming.....	68
2.2 Configuring Individual IP Cameras	68
2.2.1 Configuring Video Settings.....	69
2.2.2 Configuring Audio Settings.....	71
2.2.3 Configuring General Settings	72
2.3 Connection through RTSP, ONVIF & PSIA.....	73
2.4 On Demand Display.....	76

IP Camera Setup

2.1 Adding IP Cameras

There are several ways to connect IP devices to GV-VMS, and the procedures may vary depending on the device. To access the IP Device Setup page, click **Home**  > **Toolbar**  > **Configure**  > **Camera Install**.

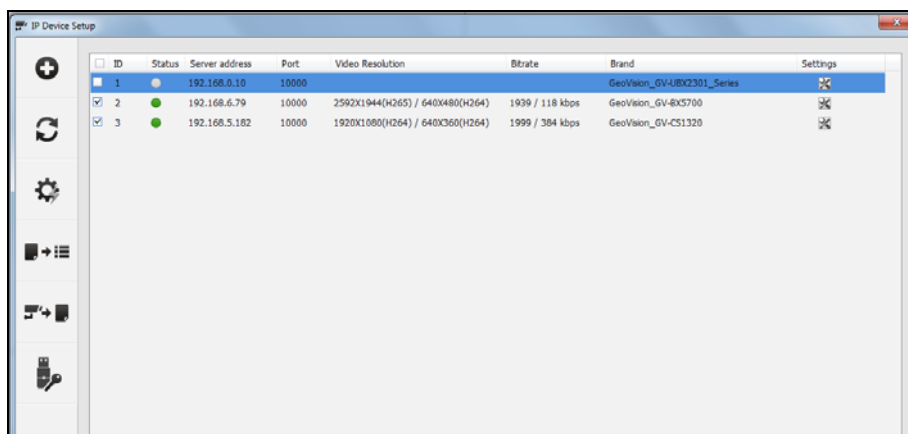







Figure 2-1

- To manually set up an IP device, click **Add Camera** .
- To detect for IP devices on the LAN, click **Scan Camera** .
- To detect for and automatically add multiple IP devices on the LAN, click **Automatic Setup** .
- To import IP devices from the GV-IP Device Utility, click **Import Camera** .
- To map IP devices through the GV-IP Device Utility, click **IP Device Utility** .
- To license GV-VMS Pro and third-party cameras using software license, click **GeoVision License Activation Tool** , and see the [technical notice](#) for instructions.

For details on Automatic Setup, refer to *Adding Cameras* in Chapter 1. For other methods, refer to the sections below.

Third-Party IP Devices

Aside from GV-IP devices, GV-VMS also supports third-party IP devices, through ONVIF, RTSP and/or PSIA. For the supported IP devices, refer to the [Supported IP Camera List](#)

In the event of unbalancing to detect third-party device(s) through Scan Camera or Automatic Setup, the device can be added through **Manual Setup**. See *Connection through RTSP, ONVIF & PSIA* later in this chapter.

2.1.1 Adding Cameras Manually

1. To manually add IP devices, click **Add Camera**  in the IP Device Setup page (Figure 2-1).
2. Type the IP address, username and password of the IP device. Modify the default HTTP port **80** if necessary.
3. Select a camera brand and model name from the **Brand** and **Device** drop-down lists, respectively.

This dialog box appears.

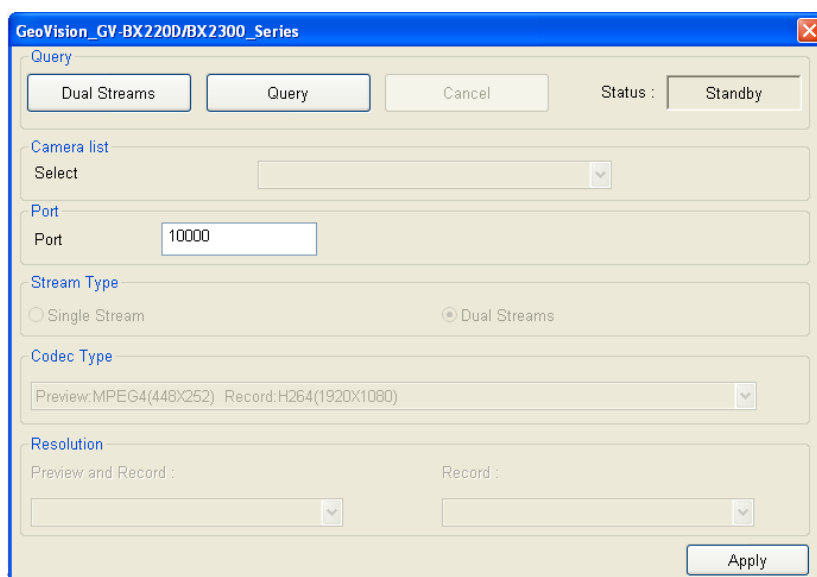

Figure 2-2

4. Configure the options listed below, which may vary between camera brands.
 - **Dual Streams:** GV-IP Cameras are set to dual streams by default. Select this option to apply the dual-streaming settings (lower resolution for live view and higher resolution for recording) if the camera supports dual streams.
 - **Query:** Detect and apply the current codec and resolution setting on the camera. This function may not be available for some third-party cameras.
 - **Camera list:** Select a camera number.

- **Port:** Modify the video streaming port of 10000 if necessary.
 - **Stream Type:** You may have the option of **Single Stream** or **Dual Streams** depending on camera models.
 - **Codec Type:** You may have different codec options depending on camera models. If the selected camera supports dual streaming, the live view codec and recording codec can be set differently.
 - **Resolution:** You may select the different resolutions for live view and recording.
5. Click **Apply** to add the IP camera to the IP Device List.
 6. To connect the added camera, select the checkbox beside the **ID** column. The **Status** icon turns green upon successful connection, with the video resolution and bit rate being displayed in the correspondent columns.













<input type="checkbox"/>	ID	Status	Server address	Port	Video Resolution	Bitrate	Brand	Setting
<input checked="" type="checkbox"/>	1		192.168.3.151	10000	1920X1080(H264) / 448X252(H264)	6902 / 51 kbps	GeoVision_GV-BX5200/BX5300_Series	
<input checked="" type="checkbox"/>	2		192.168.6.15	10000	1920X1080(H264) / 448X252(H264)	6854 / 137 kbps	GeoVision_GV-BX2200/BX2300_Series	
<input checked="" type="checkbox"/>	3		192.168.7.101	10000			GeoVision_GV-BL1500	

Figure 2-3

7. To change the number of the camera, click the device's ID and select a desired number. Note this function is only available for disconnected cameras.

Note: The indication of status icons is as below.

-  **Connected** The camera is connected.
 -  **Connecting** GV-VMS is trying to connect to the camera.
 -  **Connection Failed** Unable to connect to the camera. Place the cursor on the red icon to see the error message.
 -  **Inactive Camera** The camera is inactive. Select the checkbox to connect to the camera.
 -  **Started Monitoring** The camera is under monitoring.
 -  **Pre-Rec Enabled** Pre-recording is enabled.
-

Tips: You can access the camera's own configuration interface by right-clicking the IP camera and selecting **Remote Camera Setting**.

2.1.2 Scanning for Cameras

1. To detect for IP devices on the LAN, click **Scan Camera**  in the IP Device Setup page (Figure 2-1). The Scan Camera dialog box appears.
2. Click **Start Scan**. The IP devices detected are displayed.
3. Double-click the IP device you wish to connect to, type its username and password and click **OK**. Figure 2-2 appears.
4. Click **Apply**. The IP camera is added to the IP Device List and automatically enabled for connection.

2.1.3 Mapping GV-IP Cameras using GV-IP Device Utility

GV-IP Device Utility detects all available IP devices within the LAN and allows users to map detected cameras to the specified channels. Users can then export the device list and import it into GV-VMS. In addition, GV-IP Device Utility also lets users to quickly set IP addresses, upgrade firmware, export/import device settings for and reboot IP devices.

Click **IP Device Utility**  in the IP Device Setup page (Figure 2-1). All the available IP cameras on the LAN are detected and listed in the window.

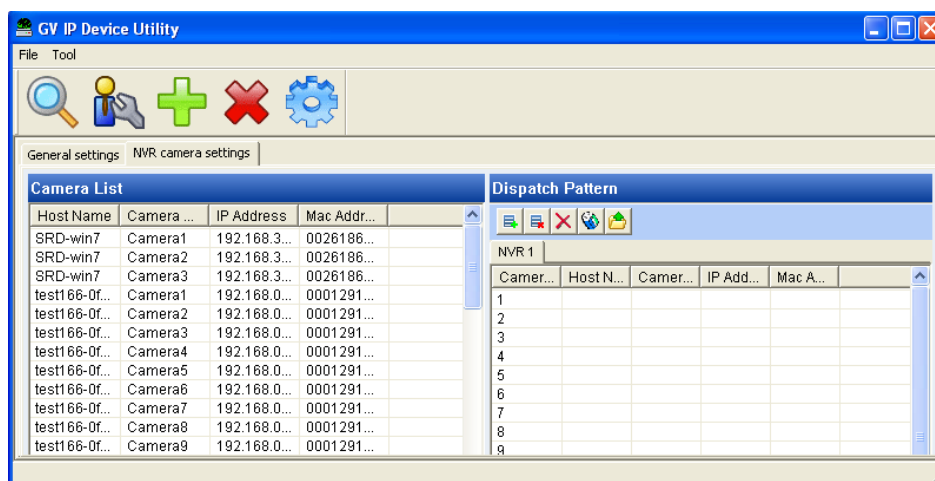



Figure 2-4

To map IP cameras to the channels of GV-VMS, see *7. Assigning Camera Channels for GV-DVR / NVR / VMS* in [GV-IP Device Utility Guide](#).

2.1.4 Adding Cameras of Mobile Devices using GV-Live Streaming

Only supported by GV-VMS V18.1 or later, GV-Live Streaming is a paid mobile app that allows the camera of your Android / iOS mobile device to connect and stream live video to GV-VMS via GV-Relay. For details of GV-Live Streaming, see [GV-Live Streaming Installation Guide](#).

2.2 Configuring Individual IP Cameras

To configure the IP camera settings such as video, audio and other general settings, click the **Setup** button  of the connected camera on the IP Device List.

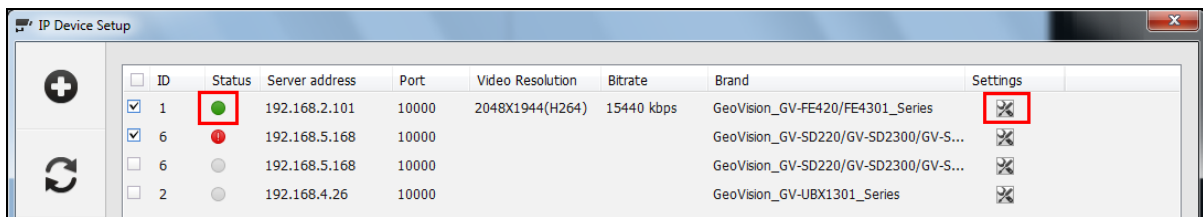

Figure 2-5

2.2.1 Configuring Video Settings

You can configure video settings such as frame rate, codec type and resolution of the camera.

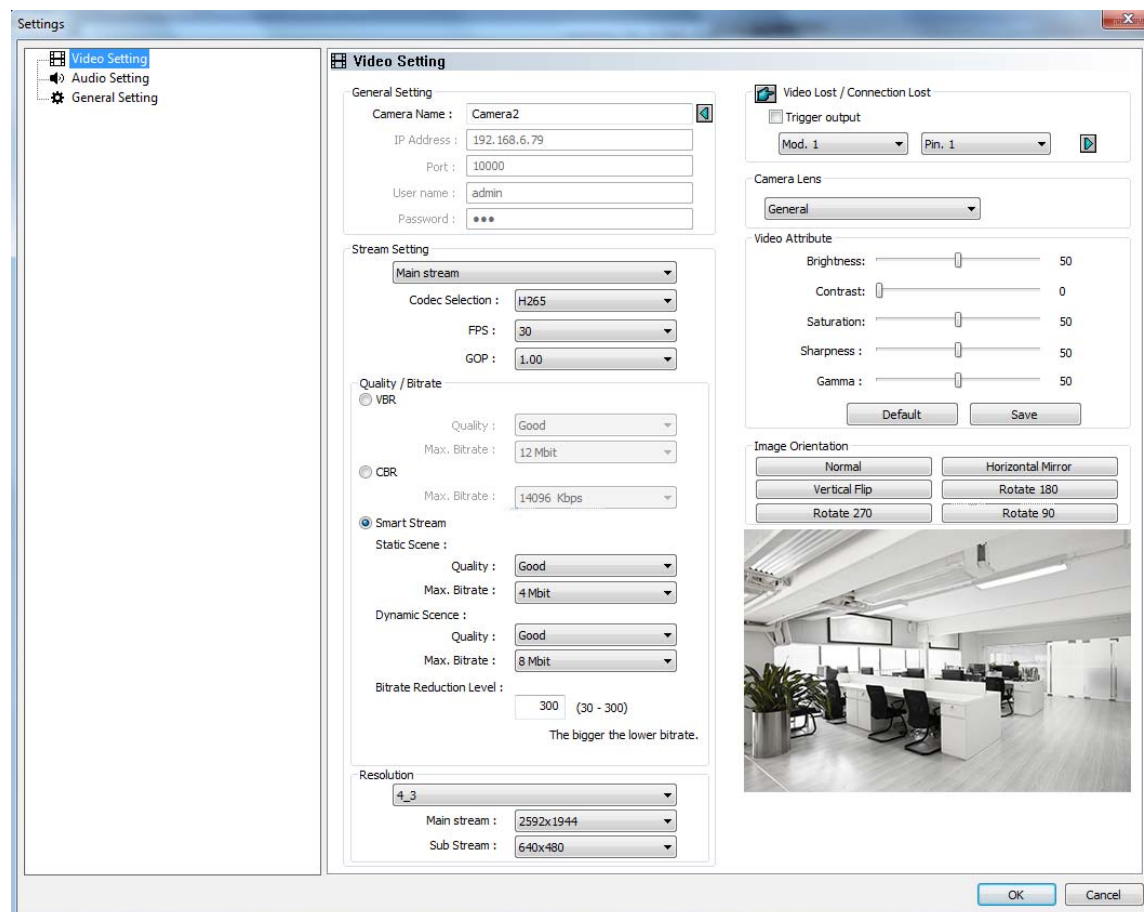

Figure 2-6

[Stream Setting] Select a stream from the drop-down list. Settings for Main Stream will be used for recording. Live view can use either Main Stream or Sub Stream depending on the On Demand settings. For details, see the *On Demand Display* section later in this chapter.

- **Codec Selection:** Set the codec to **MJPEG**, **H.264**, or **H.265**.
- **FPS:** Set the number of frames per second.
- **GOP:** Set the number of seconds between each key frame. For example, when the FPS is set to 30, a GOP of 0.5 means there will be 1 key frame among every 15 frames.
- **Quality and Bitrate:** When using the H.264 / H.265 codec, you can select between **VBR** and **CBR**.
 - **VBR (Variable Bitrate):** The quality of the video stream is kept as constant as possible at the cost of a varying bitrate. Set the image quality to one of the 5 standards: **Standard**, **Fair**, **Good**, **Great** and **Excellent**. Set a **Max. Bitrate** if needed, or select **Auto** if you do not want to enable this function.

- ⊙ **CBR (Constant Bitrate):** CBR is used to achieve a set bitrate by varying the quality of the H.264 / H.265 stream. Select one of the bitrates from the drop-down list.
- **Smart Streaming:**
 - ⊙ **Static Scene:** Set the image quality to one of the 5 standards: **Standard, Fair, Good, Great** and **Excellent**. Set a **Max. Bitrate** if needed.
 - ⊙ **Dynamic Scene:** Set the image quality to one of the 5 standards: **Standard, Fair, Good, Great** and **Excellent**. Set a **Max. Bitrate** if needed.
 - ⊙ **Bitrate Reduction Level:** The bigger the value the more bitrates can be reduced in static scenes, thus saving the recording size.
- **Resolution** Change the display ratio and resolution.

[Video Lost / Connection Lost]

- **Trigger Output:** Trigger the specified output module upon video lost or connection lost until the output device is manually turned off. To configure the output device, see *I/O Device Setup* in Chapter 6.
 - ⊙ **Right-Arrow button:** Set the counting time between 0 and 1000 seconds to delay the activation of the specified output module.

[Camera Lens] Select **Wide Angle** if you want to correct warping toward the edge of the camera image. See *Wide Angle Lens Dewarping* in Chapter 3 for details.

If you are using third-party fisheye cameras, select **IMV1 Panorama** for cameras installed with an ImmerVision IMV1 Panorama Lens, and select **Fisheye** for other third-party fisheye cameras. Refer to *Setting Up a Third-Party Fisheye Camera* in Chapter 3 for details.

[Video Attribute] Adjust video characteristics, such as brightness, contrast, saturation, sharpness and gamma.

[Image Orientation] Adjust the image orientation by selecting **Normal, Horizontal Mirror, Vertical Flip, Rotate 180, Rotate 90** and **Rotate 270**.

Note:

1. Changes made to the Video Setting page will change the settings on the IP camera.
 2. The Image Orientation options for **Rotate 90** and **Rotate 270** are only available for GV-IP Cameras that support the function.
-

2.2.2 Configuring Audio Settings

On the Audio Setting page, you can adjust audio devices and listen to live sound.

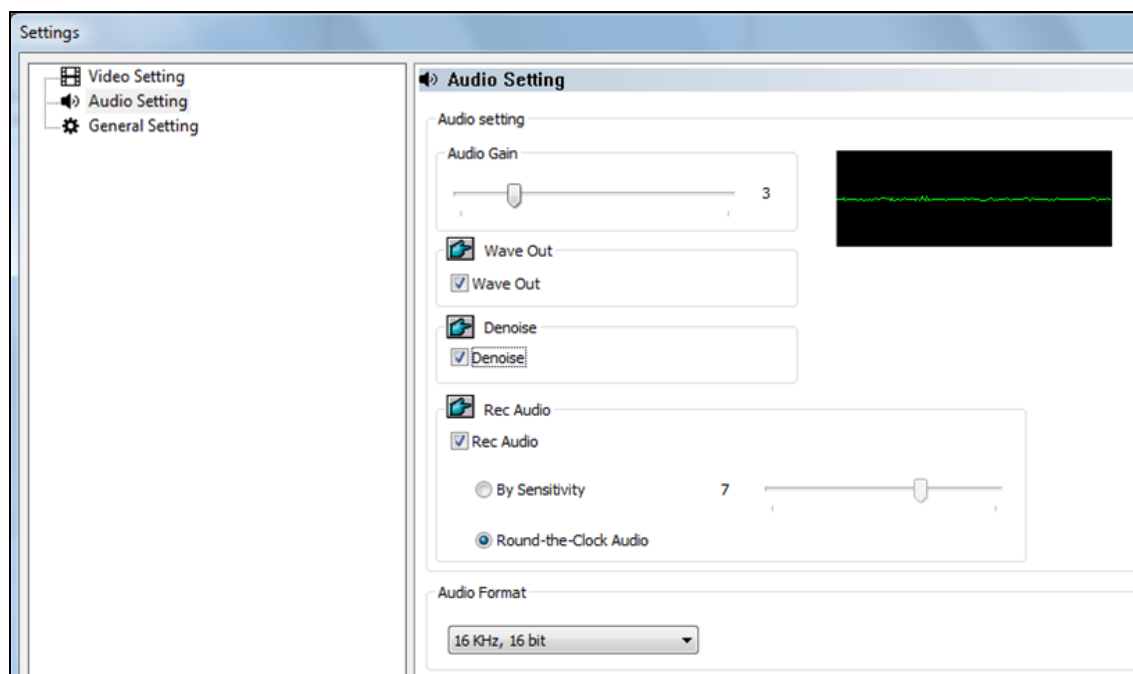

Figure 2-7

- **Audio Gain:** Increase or decrease the gain of the microphone.
- **Wave Out:** Select to listen to the audio around the camera.
- **Denoise:** Select to reduce audio noise.
- **Rec Audio:** Select **Rec Audio** to record the audio around the camera.
 - ⊙ **By sensitivity:** Audio recording is activated when the volume reaches the sensitivity level indicated.
 - ⊙ **Round-the-Clock Audio:** Audio recording is continuously enabled.
- **Audio Format:** Select an audio format from the drop-down list. The default is **16 KHz, 16 bit**.

2.2.3 Configuring General Settings

You can configure the general settings, such as for video recording.

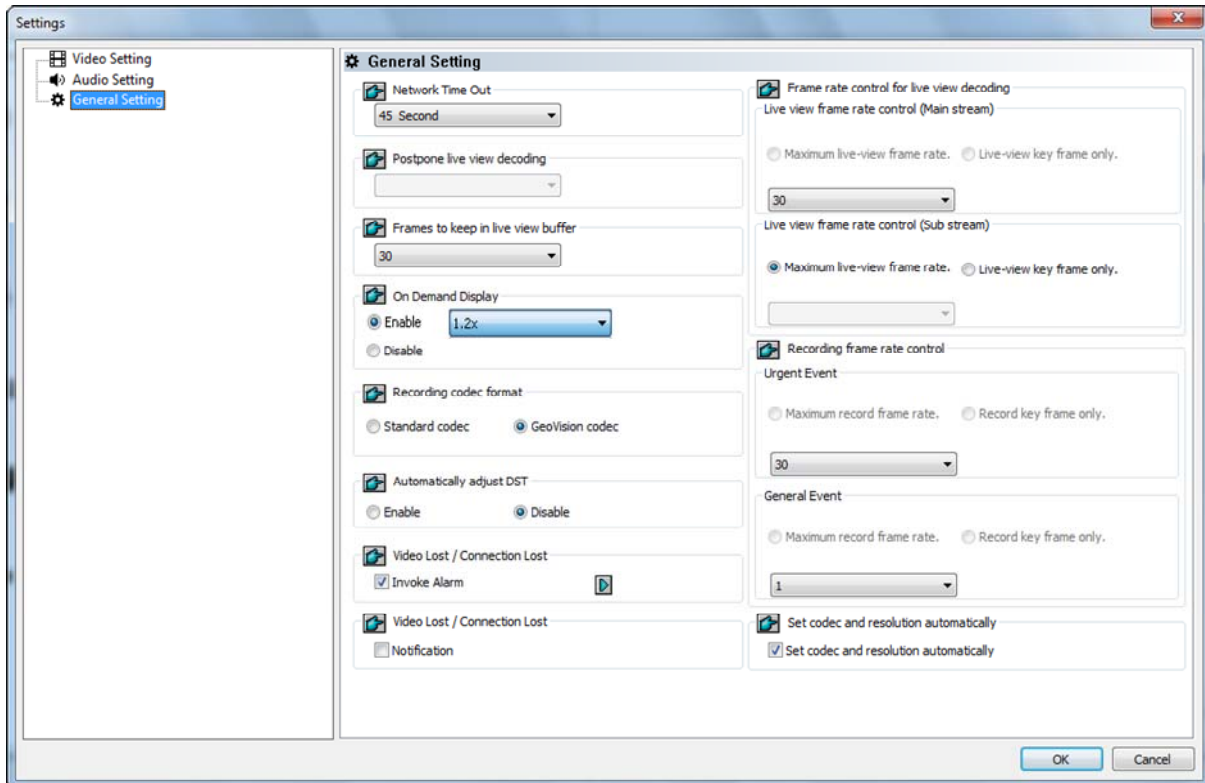





Figure 2-8

- **Network Time Out:** When network disconnection exceeds the specified time period, the status icon on the IP Device List (Figure 2-1) becomes yellow.
- **Live View Decode Postpone Time:** Specify the number of milliseconds to postpone live view decoding. When the network connection with the IP device is unstable or when the time length between frames is not evenly distributed, postponing the live view decoding will make the video smoother. Note this function is only available for configuration when the camera is disconnected.
- **Frames to Keep in Live View Buffer:** Specify the number of frames to keep in the live view buffer. When CPU performance is insufficient, you can reduce the number of frames kept in buffer to achieve a real-time appearance by dropping frames. This setting does not affect the frame rate of the recorded videos.
- **On Demand Display:** Enable automatic adjustment of live view resolution. For details, see the *On Demand Display* section later in this chapter.
- **Recording Codec Format:** Specify whether to record in standard or GeoVision codec.
- **Automatically Adjust DST:** If enabled, the time on the GV-IP Device Web interface will be synchronized with the time of the GV-VMS when DST period starts or ends on the GV-VMS.

- **Video Lost / Connection Lost (Invoke Alarm):** Enable if you want to trigger an alarm sound upon connection lost. Click the Arrow button to select a sound.
- **Video Lost / Connection Lost (Notification):** Enable if you want to send an e-mail notification upon connection lost. See *Setting Up Email Notification* in Chapter 1 to set up the e-mail server.
- **Live View Decode Frame Control (Main / Sub Stream):** Set the live view frame rate for main stream and sub stream.
 - ⊙ When using **MJPEG**, every frame is a key frame, so the options of **Max. frame** and **Key only** are grayed out.
 - ⊙ When using **H.264 / H.265**, only one key frame is transmitted per the specified number of frames, so you can select **Key only** to decode key frames only and omit all intermediate frames or **Max. frame** to include all frames.
- **Recording Frame Rate Control:** Set the recording frame rate for **Urgent Event** and **General Event**. This function allows you to set different recording frame rates for motion, non-motion and other alarm events. See *Setting Recording Settings for Individual Cameras* in Chapter 1.
 - ⊙ When using **MJPEG**, every frame is a key frame, so the options of **Max. frame** and **Key only** are grayed out. You can specify the recording frame rate for **Urgent Event** and **General Event** respectively.
 - ⊙ When using **H.264 / H.265**, only one key frame is transmitted per the specified number of frames. You can select **Max. frame** for **Urgent event** and select **Key only** for **General event**.
- **Set Codec and Resolution Automatically:** If enabled, the GV-VMS will resume the configured codec and resolution when it detects the changes made by the camera.

2.3 Connection through RTSP, ONVIF & PSIA

You can add IP devices to the GV-VMS through RTSP, ONVIF and/r PSIA if the protocols are supported by the device. This is useful for setting up devices not listed within the [Supported IP Devices](#).

1. To add through the abovementioned protocols, click **Home**  > **Toolbar**  > **Configure**  > **Camera Install**.

2. Click **Add Camera**  to manually add an IP camera. This dialog box appears.
3. Type the IP address, username and password of the IP camera. Modify the default HTTP port if necessary.
4. Select **Protocol** from the **Brand** drop-down list.
5. Select the protocol that is supported by your IP camera from the **Device** drop-down list.

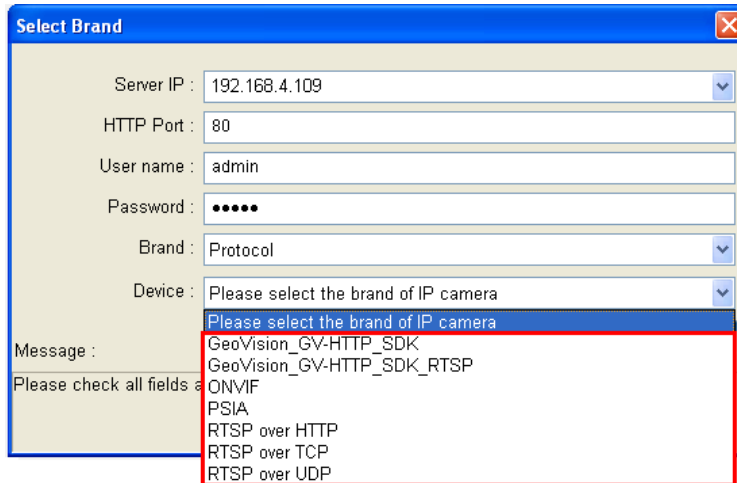



Figure 2-9

- **GV_HTTP_SDK:** This option is for SDK users. The RTSP protocol uses a HTTP port for data streaming from the IP camera.
- **GV_HTTP_SDK_RTSP:** This option is for GeoVision SDK users. The RTSP protocol uses a HTTP port for data streaming from the IP camera.
- **ONVIF:** This option is for connecting the camera using ONVIF standards.
- **PSIA:** This option is for connecting the camera using PSIA standards.
- **RTSP over HTTP:** The RTSP protocol uses a HTTP port for data streaming from the IP camera.
- **RTSP over TCP:** The RTSP protocol uses a TCP port for data streaming from the IP camera.
- **RTSP over UDP:** The RTSP protocol uses an UDP port for data streaming from the IP camera.

6. If you select **ONVIF**, this dialog box appears after the system confirms that the camera is ONVIF compatible. Click **Dual Stream** to enable the second stream if needed, and click the **Setting** button  next to Stream1 and Stream 2 to adjust the following information.

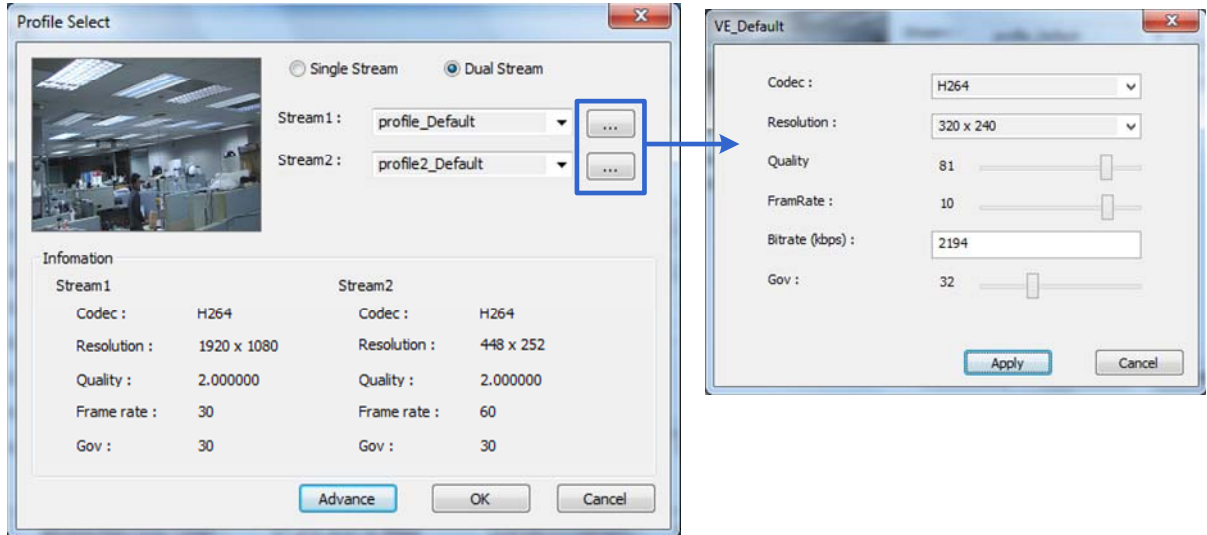



Figure 2-10

- **Codec:** Select H.264 or JPEG.
 - **Resolution:** Set a resolution.
 - **Quality:** Adjust the image quality. The range of image quality varies for different brands.
 - **Frame Rate:** Set a maximum frame rate. The range of frame rate varies for different brands.
 - **Bitrate:** The current bit rate setting of the IP device will be displayed. You can adjust the bit rate limit within the device's supported bit rate range if needed.
 - **GOV:** Set the number of frames between each key frame. For example, a GOV of 10 means there will be 1 key frame every 10 frames.
7. If you select **PSIA**, a dialog box appears after the system confirms that the camera is PSIA compatible. Click **Apply**.
8. If you select **RTSP**, select **Dual Streams** to enable the Sub Stream if needed and type the RTSP link address.
- For the RTSP command, consult the documentation of your IP camera. For instance:
- For an AXIS IP camera, enter RTSP://<IP of the IP camera>/<codec>/media.amp
 - For a HIKVISION IP camera, enter RTSP://username:password@<IP of the IP Camera>
9. Click **OK** to add the IP camera to the IP Device List.

2.4 On Demand Display

For cameras that support dual streaming with different resolutions, you can select the **On Demand Display** option to enable automatic adjustment of live view resolution. This option produces good image quality without causing high CPU usage.

You will need to set a value of **X times the resolution of the sub stream** as the threshold. When the camera image on the screen is bigger than the threshold, the system will switch to the higher resolution streaming, usually the main stream. Such adjustment is enabled when using the view modes that require higher quality images, such as single view or PIP / PAP mode. The system will switch to the lower resolution streaming to reduce CPU usage when watching live view in view modes where higher resolution does not make a difference, such as highly divided divisions.

1. Make sure the IP camera has been added to the GV-VMS and you have selected **Dual Stream** during setup. For details on adding IP camera, see *Adding IP Cameras* earlier in this chapter.
2. In the IP Device Setup dialog box (Figure 2-1), click the **Setup** button  of the desired connected camera within the IP Device List and select **General Setting**.
3. In the On Demand Display field, click **Enable** and select a value. When the camera image on the screen is **X times** bigger than the resolution of sub stream, the system will switch to the higher resolution streaming.

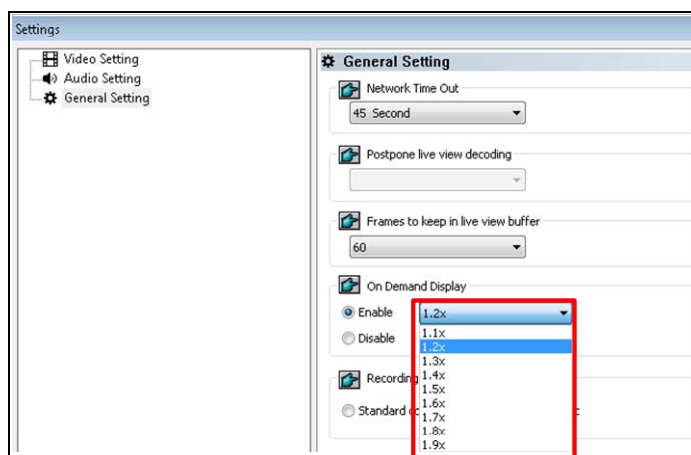

Figure 2-11

Note:

1. The **On Demand Display** function is not supported for **Privacy Mask**.
 2. The **On Demand Display** function is not supported by GV-Fisheye cameras
-

Application Example

The resolution of sub stream is 640 x 480, and a value of **1.2 times the resolution of the sub stream** has been selected for the On Demand Display function.

- **Higher Resolution Streaming**

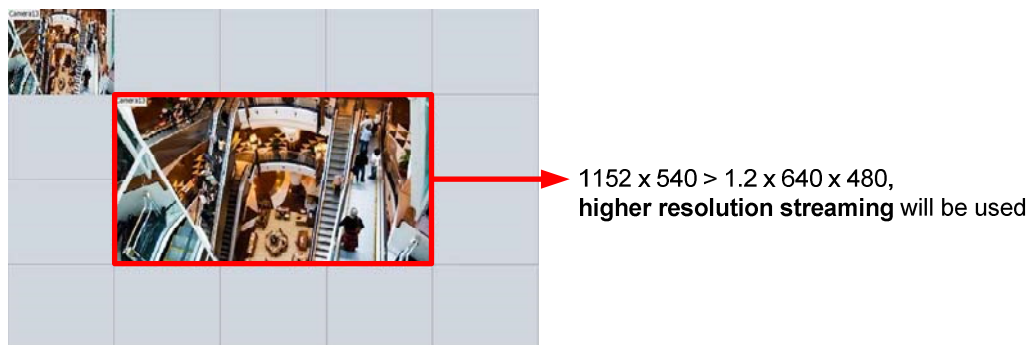

Figure 2-12

The camera image in the middle has a resolution of 1152 x 540, so the higher resolution streaming will be used, because 1152 x 540 is bigger than 1.2 x 640 x 480.

- **Lower Resolution Streaming**



Figure 2-13

After switching to 9-channel screen division, the resolution for each channel is 640 x 360, which is smaller than 1.2 x 640 x 480, so the lower resolution streaming will be used.

Chapter 3

Video Analysis	80
3.1 Object Counting and Intrusion Alarm	80
3.1.1 Object Counting.....	80
3.1.2 Intrusion Alarm.....	83
3.2 Object Index.....	86
3.2.1 Setting Object Index.....	86
3.2.2 Viewing Object Index	88
3.2.3 Searching Object Index	89
3.3 Automatic Video Snapshots	90
3.3.1 Setting Video Snapshots.....	90
3.3.2 Searching Video Snapshots	91
3.4 Face Detection.....	92
3.4.1 Setting Face Detection.....	92
3.4.2 Searching Face Detection Snapshots	93
3.5 Face Count	94
3.5.1 Installing the Camera.....	94
3.5.2 Setting Face Count.....	95
3.6 Face Recognition.....	98
3.6.1 Enrolling Face Data.....	99
3.6.2 Setting Face Groups	102
3.6.3 Synchronizing Face Database	103
3.6.4 Defining Access Schedule	104
3.6.5 Setting Recognition Alerts	107
3.6.6 Configuring Face Recognition Database	108
3.6.7 Backing up Face Database.....	109
3.6.8 Face ID — Live Recognition Profiles	109
3.6.9 Viewing and Searching for Face Recognition Events	110
3.6.10 Tracking Recognized Faces.....	111
3.6.11 Integrating Face Recognition to Access Control.....	114
3.6.12 Batch Enrolling Faces and Access Cards.....	117
3.7 Face Detection by Camera.....	121
3.7.1 Configuring for FD Cameras	121
3.7.2 Face List — Live Face Detection.....	122

3.8	Privacy Mask Protection.....	123
3.8.1	Setting a Privacy Mask.....	123
3.8.2	Granting Access Privileges to Recoverable Areas.....	124
3.9	Panorama View.....	125
3.9.1	The Main Window.....	125
3.9.2	Stitching a Panorama View with Overlapping Areas.....	126
3.9.3	Easy Mode with No Overlapping Areas.....	128
3.9.4	Accessing a Panorama View.....	130
3.10	Video Defogging.....	131
3.11	Video Stabilization.....	132
3.12	Wide Angle Lens Dewarping.....	133
3.13	Crowd Detection.....	135
3.14	Advanced Scene Change Detection.....	137
3.15	Advanced Unattended Object Detection.....	139
3.16	Advanced Missing Object Detection.....	142
3.17	Text Overlay.....	144
3.18	Fisheye View.....	145
3.18.1	Setting Up a GV-Fisheye Camera.....	146
3.18.2	Setting Up a Third-Party Fisheye Camera.....	148
3.18.3	Object Tracking.....	150
3.19	Video Analysis by Camera.....	155
3.20	Heat Map.....	158
3.20.1	Enabling Heat Map.....	158
3.20.2	Accessing the Heat Map in Recordings.....	160
3.21	Event Alert through E-mail Notification.....	161
3.22	PTZ Object Tracking.....	162
3.22.1	Dual-Camera Tracking.....	162
3.22.2	Single Camera Tracking.....	164
3.23	Panoramic PTZ Object Tracking.....	166
3.23.1	Accessing the Live View.....	166
3.23.2	Automatic Object Tracking.....	167
3.24	Specifications.....	171

Video Analysis



3.1 Object Counting and Intrusion Alarm

Object Counting provides bi-directional counting of objects under the surveillance area. It is able to count any moving objects (such as vehicles), people or animals. Intrusion alarm can be set to send notifications when an object moves into the defined region.

Note: It is not recommended to apply the counter function to Fisheye cameras.

3.1.1 Object Counting

You can select up to 16 cameras to set up Object Counting.

1. Click **Home**  > **Toolbar**  > **Configure**  > **Video process**. The Setup dialog box appears.
2. From the Video Analysis drop-down list, select **Counter/Intrusion Alarm Setting**, select the desired cameras and click **Setting**. This page appears.

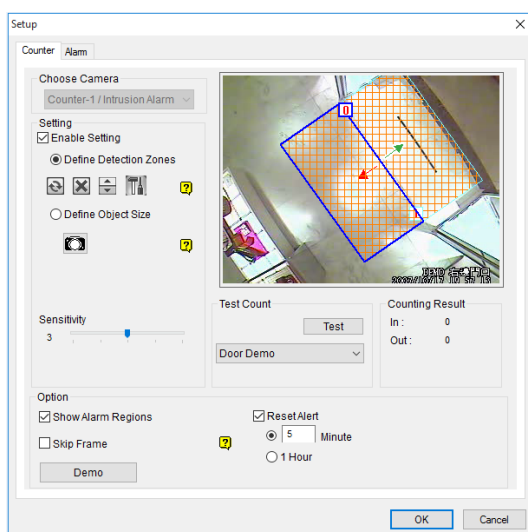





Figure 3-1

3. Select a desired camera under **Choose Camera** and select **Enable Setting** to define the counter.

■ **Define Detection Zones:** Select this option to define the detection zones.

a. On the live view, draw at least two boxes to mark the in and out detection zones.

Each detection zone is numbered. Use these buttons to edit the detection zones:

Name	Button	Function
Reverse		Flips the detection zone.
Switch		Switches to another detection zone.
Delete		Deletes the detection zone.
Direction		Configures the in and out directions. See Step 3-b.

b. Click the  button to define the in and out criteria. This dialog box appears.

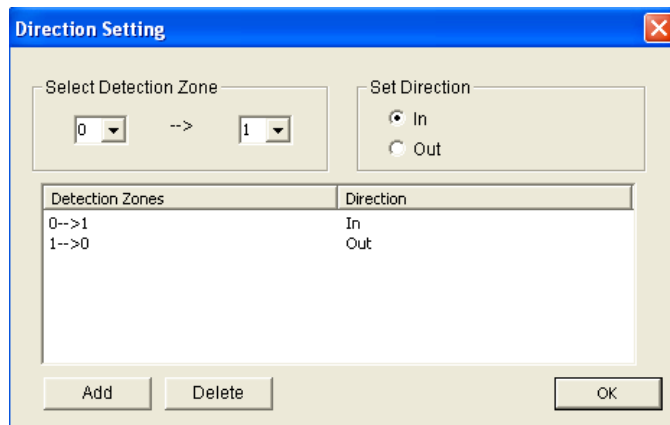

Figure 3-2

c. Select In/Out under **Set Direction** and define the direction in **Select Detection Zone**.

d. Click **Add**. The setting is added and appears in the table below.

e. Click **OK**. The directions are added and indicated by arrows on the live view.

■ **Define Object Size:** Select this option and click  to pause the live view.

Outline a size matching that of targeted objects on the live view. Click  to resume.

4. To test your counting settings, select **Live** from the Test Count drop-down list and click the **Test** button to start testing. The number in **Counting Result** should change as objects move through the detection zone. Optionally use the **Sensitivity** slider to adjust detection sensitivity as needed.
5. Click **OK** to apply the settings.
6. Start monitoring to begin counting. The counted objects, people or animals are indicated on the live view with yellow boxes.

More options in the Counter dialog box:

- **Show Alarm Regions:** Displays the detection zones on the preview image.
- **Skip Frame:** Skips frames to lower the CPU loading, where the system only counts objects every three frames. This option may reduce the accuracy of counting result.
- **Reset Alert:** Specify a time interval, between 1 and 1440 minutes, to reset the recorded counting result in the system log.

Note:

1. Draw the detection zones as closely as possible to avoid omission of counting when target objects show up in the unmarked area and move only through one of the two boundaries.





Figure 3-3

2. To include counting results in the recorded files, see *Setting Text Overlay* later in this chapter.
 3. To view the logs for counter events, click **View Log, Toolbar, Tools, System Log, Monitor Table** and click the **Counter** tab.
 4. Optionally create a schedule for counter to be enabled only at the time periods specified. For details, see *Creating Schedules* in Chapter 1.
-

3.1.2 Intrusion Alarm

Up to 16 cameras can be set up for Intrusion Alarm.

1. To set Intrusion Alarm for object(s) entering a defined region Click **Home**  > **Toolbar** > **Configure**  > **Video process**. The Setup dialog box appears.
2. Select **Counter/Intrusion Alarm Setting** in Video Analysis, select the desired camera, click **Setting** and click the **Alarm** tab. This dialog box appears.

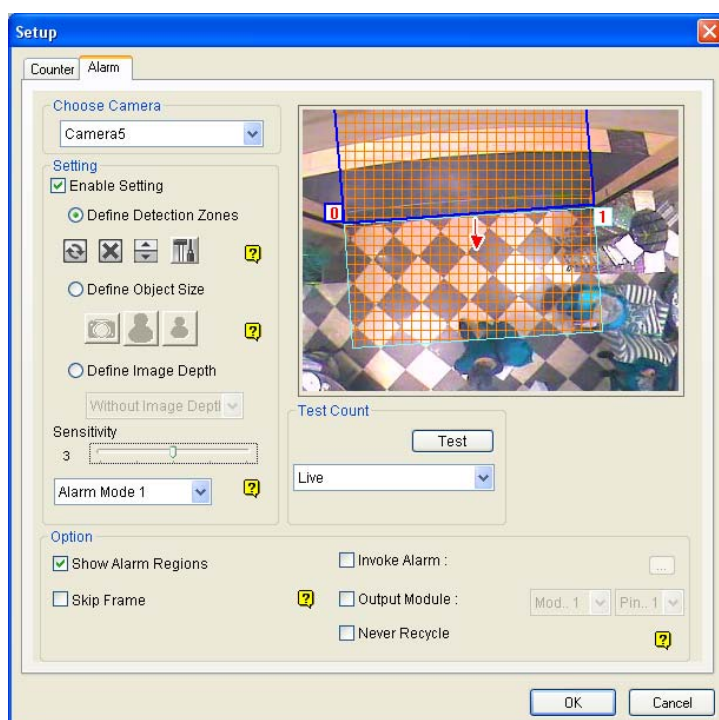







Figure 3-4

3. Select a desired camera under **Choose Camera** and select **Enable Setting** to define the intrusion alarm.
 - **Define Detection Zones:** Select this option to define the detection zones.
 - a. On the live view, draw at least two boxes to mark the in and out detection zones. Each detection zone is numbered. Use these buttons to edit the detection zones:

Name	Button	Function
Reverse		Flips the detection zone.
Switch		Switches to another detection zone.
Delete		Deletes the detection zone.
Direction		Configures the in and out directions. See Step 3-b.

- b. Click the  button to define the alarm criteria. This dialog box appears.

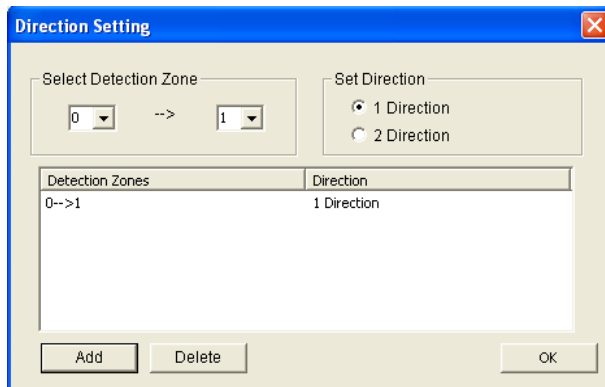



Figure 3-5

- c. Select 1 Direction or 2 Direction under **Set Direction** and define the direction in **Select Detection Zone**.
- d. Click **Add**. The setting is added and appears in the table below.
- e. Click **OK**. The directions are indicated by arrows on the live view.

- **Define Object Size:** Select this option and click  to pause the live view. Outline a size matching that of targeted objects on the live view. Click  to resume.
- **Define Image Depth:** When the object moves toward or away from the camera along a path, for example, a hallway, it appears larger when it is closer to the camera and vice versa. Rather than using a fixed object size, you can define a maximum and minimum object size according to the object's proximity to the camera.

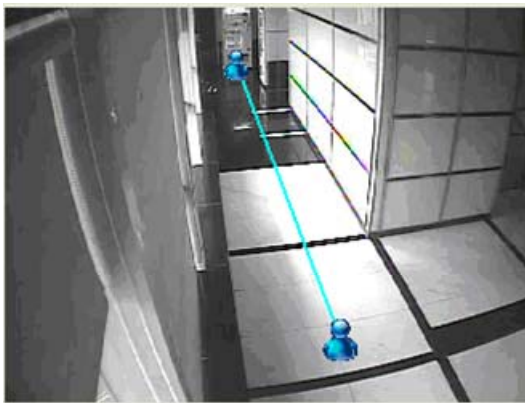





Figure 3-6

- a. Select **Define Image Depth** and select **With Image Depth** using the drop-down list. A line  appears.

- b. Drag and place the line along the path where the objects will be moving. The larger icon indicates the point closer to the camera.
 - c. Select **Define Object Size**. Click the larger icon  and click  to pause the live view. Use the mouse to outline the maximum size of objects on the live view.
 - d. Click the smaller icon  and repeat the step above to define the minimum size of objects when they are further from the camera.
4. In the Setting section, there are two kinds of alarm modes:
 - **Alarm Mode 1:** The alarm sets off when the target object moves through the first detection zone and touches the second detection zone in the defined direction.
 - **Alarm Mode 2:** The alarm sets off when the target object moves through the first detection zone and its center moves through the second detection zone in the defined direction.
 5. To set up alarm devices, configure any or both of the following options.
 - **Invoke Alarm:** Enable the computer alarm when an object enters the defined region. Click the button next to the option to assign a .wav sound file.
 - **Output Module:** Enable an installed output device when an object enters the defined region. Assign the output module and pin number.
 6. To test your alarm settings, select **Live** from the Test Count drop-down list and click **Test**. When intrusion objects are detected, the configured computer alarm or output device will be activated. Optionally adjust the **Sensitivity** slider as needed.
 7. Click **OK** to apply the setting.
 8. Enable monitoring to start intrusion detection. The detected intruding objects are indicated on the live view with red boxes.

When an intrusion event occurs, the configured computer alarm or output device will be activated, and the event will be recorded as Intruder in System Log for later retrieval

More options in the Alarm dialog box:

- **Show Alarm Regions** and **Skip Frame:** refer to More options in *Object Counting* above.
- **Never Recycle:** Alarm-triggered events will never be recycled if selected.

Note:

1. Draw the detection zones as closely as possible to avoid omission of intrusion events when target objects show up in the unmarked area and only move through one of the two boundaries.



Figure 3-7

2. To view the logs for intrusion events, click **View Log, Toolbar, Tools, System Log, Monitor Table** and click the **Monitor** tab.
 3. Optionally create a schedule for intrusion alarm to be enabled only at the time periods specified. See *Creating Schedules* in Chapter 1.
-

3.2 Object Index

The Object Index feature allows you to view the very first frame of a *continuous* movement in a video stream. With Object Index Live Viewer, you may view the most recent 50 frames captured. When accessing Object Index in ViewLog, you can easily locate and play back events by selecting and specifying the desired camera channels and time periods.

3.2.1 Setting Object Index

You can select up to 16 cameras for which their Object Index is kept.

1. Click **Home**  > **Toolbar**  > **Configure**  > **Video process**. The Setup dialog box appears.

- From the Video Analysis drop-down list, select **Object Index**, select the desired cameras and click **Setting**. This dialog box appears.

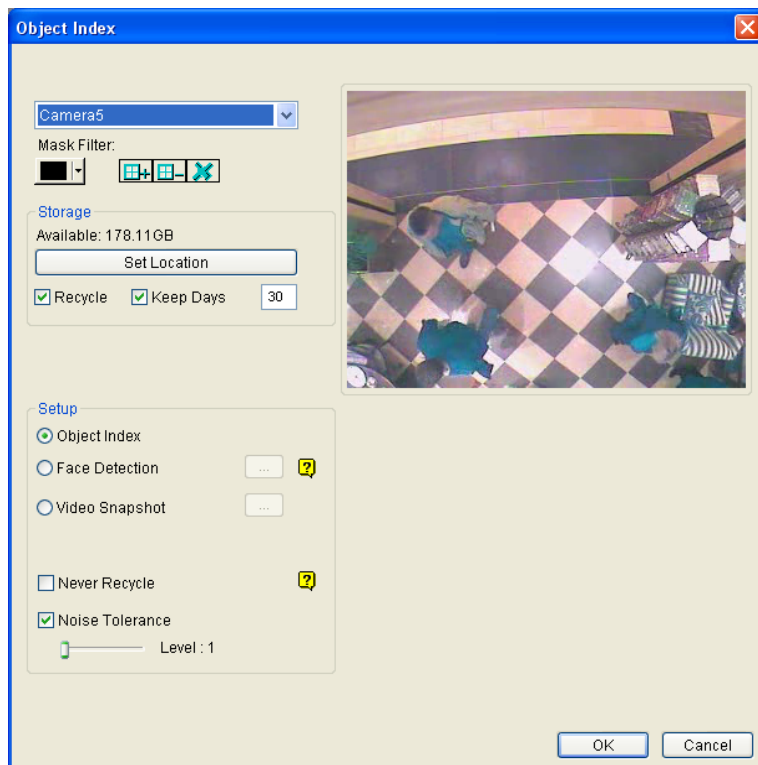





Figure 3-8

- Select one camera from the drop-down list and configure the following.
 - **Mask Filter:** Use the mouse to outline a mask area where motion will be ignored.
 - **Set Location:** Click the button to assign a path to save the log files and image snapshots.
 - **Keep Days:** Specify the number of days the log files will be kept for, from 1 to 999 days.
 - **Recycle:** Select this option for GV-VMS to recycle the oldest log files when the remaining disk space is less than 500 MB. When both Keep Days and Recycle are selected, the system reacts to whichever condition that is first met.
 - **Never Recycle:** Log files and image snapshots will not be recycled when selected.
 - **Noise Tolerance:** Use the slider to adjust the tolerance level. The higher the level, the more tolerant the system is to video noise.
- Click **OK** to apply the settings.
- Enable monitoring to start the function.

Note: Optionally create a schedule for object index to be enabled only at the time periods specified. For details, see *Creating Schedules* in Chapter 1.

3.2.2 Viewing Object Index

Once set, you can start to view the most recent frames captured, up to 50 frames, through Object Index.

1. Start camera monitoring. The detected face or objects are indicated on the live view.
2. Click **Home**  > **Toolbar**  > **Tools**  > **Live Object Index**. The Live Viewer window appears and displays the most recent 50 frames recorded.
3. Click the lock icon and select **Lock** to pause the real-time updating of Object Index.

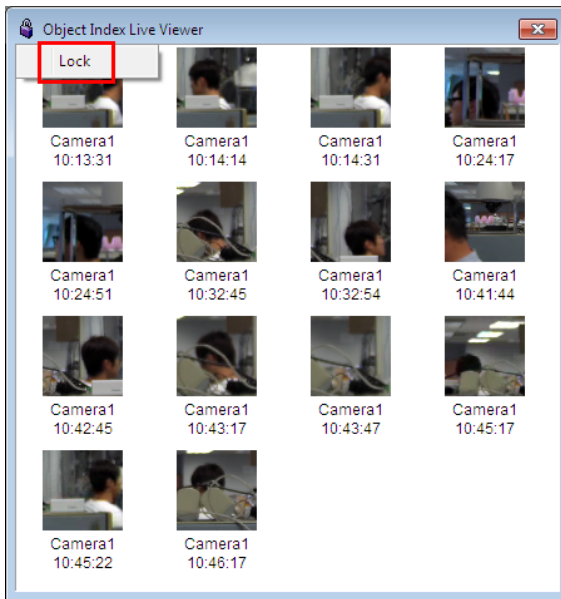





Figure 3-9

4. With the camera name and recorded time shown below each frame image, double-click an image to play back its recording. The recording will be displayed in ViewLog, where you can play it back using the Timeline.

Note: To display the corresponding recording, make sure the layout in ViewLog includes the camera channel selected.

3.2.3 Searching Object Index

In ViewLog, you can locate, and instantly play back, the frames of the desired cameras within a specified time.

1. Click **ViewLog**  > **Toolbar**  > **Tools**  > **Object Index**.
2. Only available on GV-VMS V18.1 or later, select the desired camera channels at the top and click **Refresh**  to display all the event frames of the channels selected, including the ones most recently recorded.

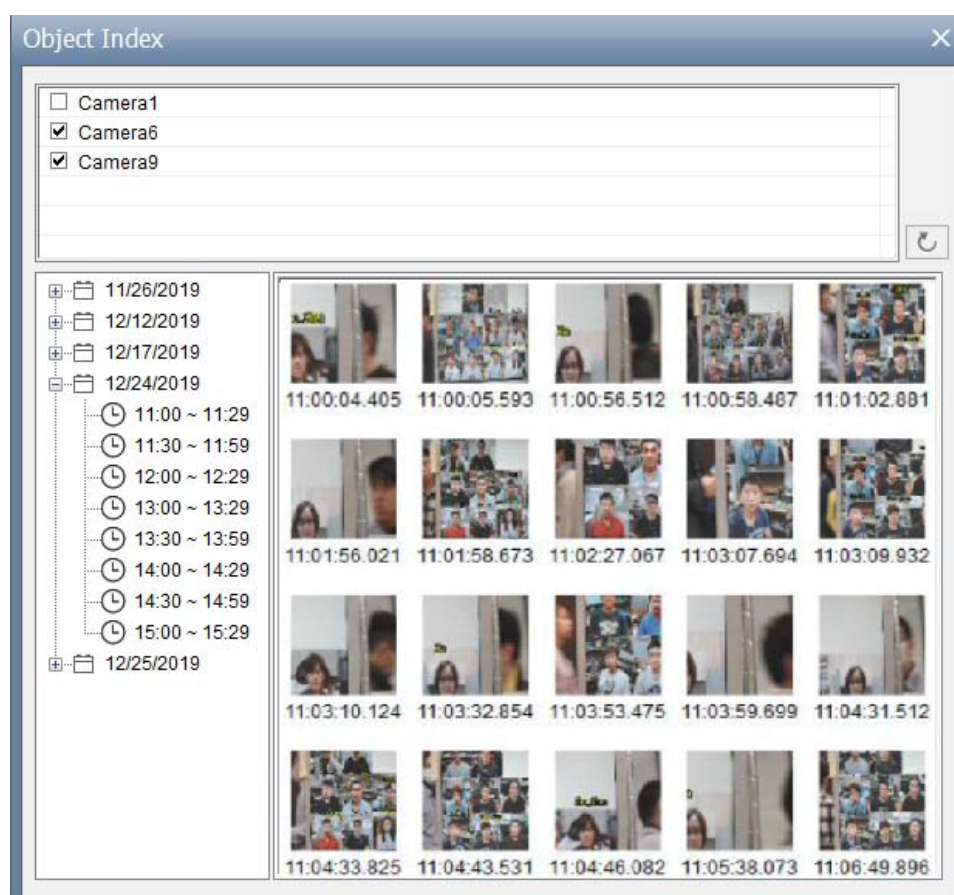

Figure 3-10

3. Select the desired date and time to display the event frames during that time period.
4. Double-click the frame you want to play back. The recording will be displayed in ViewLog, where you can play back using the Timeline.

Note: To display the corresponding recording, make sure the layout in ViewLog includes the camera channel selected.



3.3 Automatic Video Snapshots

The Video Snapshot allows the system to take up to 30 snapshots per second as monitoring starts. This function allows you to keep the surveillance records as still JPEG images instead of AVI videos when storage space is limited.

Note: After you start monitoring, the system will start taking video snapshots whether there is motion or not.

3.3.1 Setting Video Snapshots

You can select up to 16 cameras to take video snapshots.

1. Click **Home**  > **Toolbar**  > **Configure**  > **Video process**. The Setup dialog box appears.
2. From the Video Analysis drop-down list, select **Object Index**, select the desired cameras and click **Setting**. The Object Index dialog box appears.

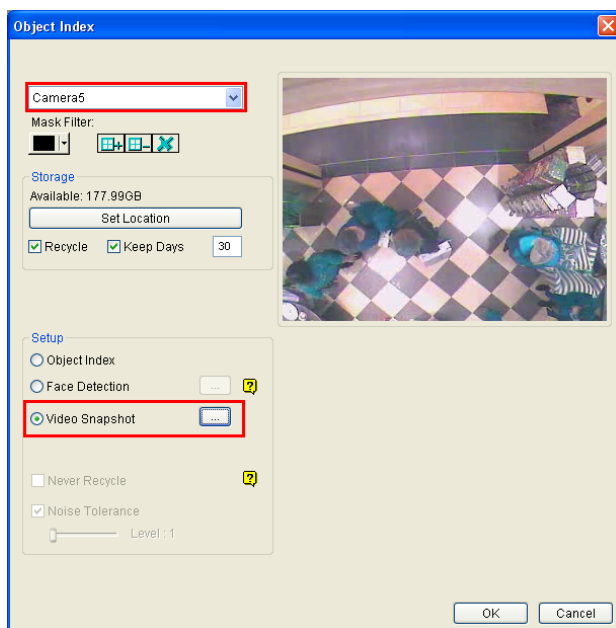

Figure 3-11

3. Select one camera from the drop-down list.
 - A. Optionally configure the Storage settings. See Step 4, *Setting Object Index* earlier in this Chapter.
 - B. Select **Video Snapshot**.

- C. Click [...] after Video Snapshot for further setup.

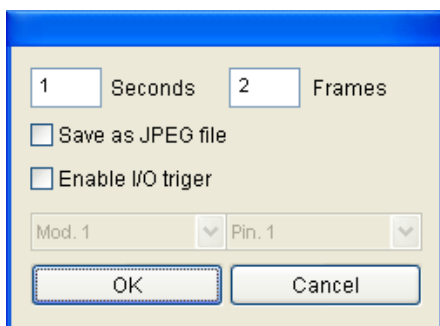





Figure 3-12

4. Specifies the frequency of automatic video snapshot. By default, the system will take 2 frames every second when the monitoring starts.
 - **Save as JPEG file:** Saves the images in JPEG format. Otherwise, you can only access the snapshots using the ViewLog player.
 - **Enable I/O Trigger:** Takes snapshots only when the assigned input device is triggered.
5. To configure another camera, select a different camera on Step 3.
6. Click **OK** to apply the settings.
7. Start monitoring to take snapshots.

Note:

1. For details on other settings of the Object Index dialog box, see Step 4, *Setting Object Index* earlier in this chapter.
 2. Optionally create a schedule for video snapshot function to be enabled only at the time periods specified. For details, see *Creating Schedules* in Chapter 1.
-

3.3.2 Searching Video Snapshots

1. To locate video snapshots of desired cameras, click **ViewLog**  > **Toolbar**  > **Tools**  > **Object Index**. A window similar to that of Object Index appears (Figure 3-10).
2. Select a desired camera channel and click **Refresh** to display all its event frames, including the ones most recently recorded.
3. Select the desired date and time to display all the video snapshots captured, along with their event frames, during that time period.

Note: When **Save as JPEG file** is enabled (Figure 3-12), you can also view the video snapshots from the directory specified by **Set Location** (Figure 3-11).



3.4 Face Detection

The Face Detection enables the system to detect and record human faces, including individual faces when a group of people enter the scene. This feature captures human faces only, ignoring other body parts, objects or background views.

Note: For settings related to GV-Face Detection (FD) cameras, see *Face Detection by Camera* later in this chapter.

3.4.1 Setting Face Detection

Up to 16 cameras can be configured for this application.

1. Click **Home**  > **Toolbar**  > **Configure**  > **Video process**. The Setup dialog box appears.
2. From the Video Analysis drop-down list, select **Object Index**, select the desired cameras, and then click **Setting**. The Object Index dialog box appears.

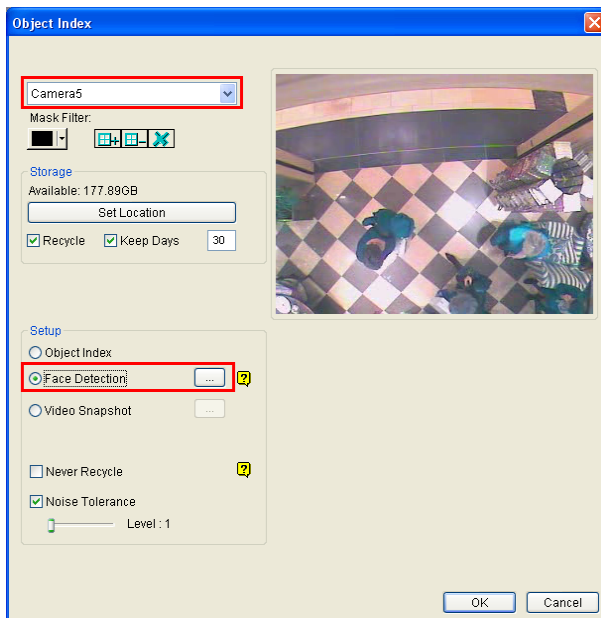

Figure 3-13

3. Select one camera from the drop-down list.
 - A. Optionally configure the Mask Filter, Storage and Noise Tolerance settings. For details, see Step 4, *Setting Object Index* earlier in this chapter.

- B. Select **Face Detection**.
- C. Click [...] after Face Detection to adjust the sensitivity. The higher the value, the more sensitive face detection is.
4. To configure another camera, select a different camera on Step 3
5. Click **OK**.
6. Start monitoring.

Note:

1. For details on other settings of the Object Index dialog box, see Step 4, *Setting Object Index* earlier in this chapter.
2. Optionally create a schedule for face detection to be enabled only at the time periods specified. For details, see *Creating Schedules* in Chapter 1.

3.4.2 Searching Face Detection Snapshots

1. Click **Home**  > **Toolbar**  > **Tools**  > **Live Object Index** to display the Live Viewer window.

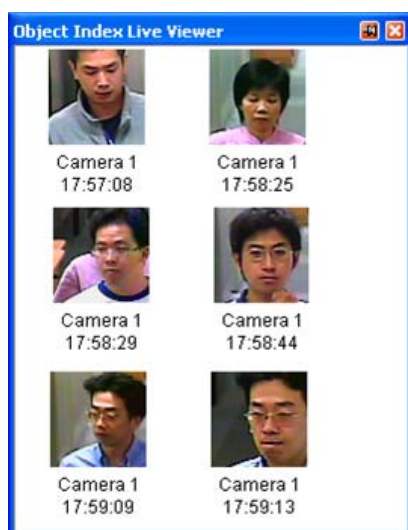

Figure 3-14

2. Double-click a desired frame to instantly play back its recorded file.

Note: Consider the following when installing the camera for face detection:

- Face contour must be clearly seen
- Only faces tilting within the range of 15° vertically and 30° ~ 45° horizontally can be detected.
- The face to be detected must cover least 1/10 of the screen.

3.5 Face Count

The Face Count function allows you to count the number of faces that appear in the image. You can also select to invoke a computer alarm or trigger an output device when a face is detected or when the system is unable to detect a face.

The number of faces counted is saved to the GV-Web Report which can analyze counting data from multiple GV-VMS. For details, see *GV-Web Report User's Manual*.

Note:

1. Up to 16 cameras can be configured for this function.
 2. The Face Count results are only available on GV-Web Report V2.2.6.0 or later.
-

3.5.1 Installing the Camera

1. Install the camera inside an entrance pointing outward. The Face Count function is designed to detect front-view faces only, and the area of the detected face must take up 10% to 50% of the live image.

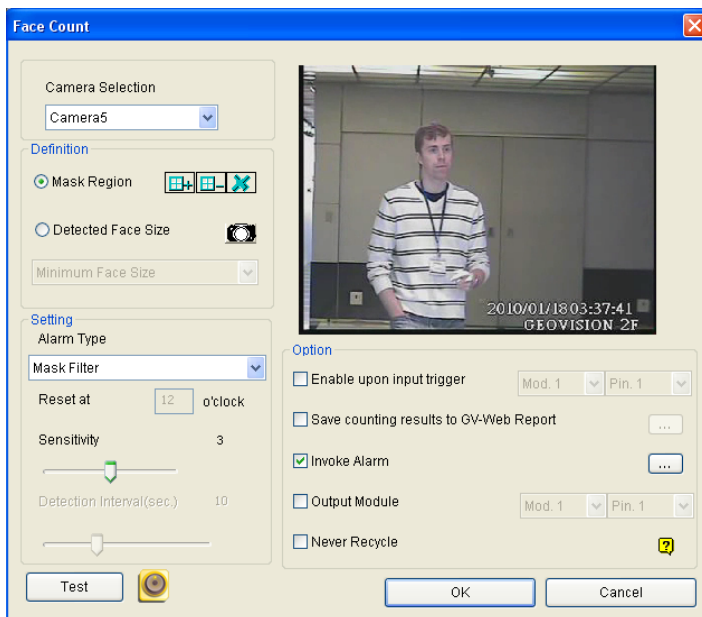





Figure 3-15

2. Avoid installing the camera where it is subjected to direct sunlight or reflections. The lighting of the entrance where you set the camera should be sufficient but not too bright or dark. Light should be distributed evenly across faces without too much light coming from one side. Sharp shadow edges in the camera view may affect the accuracy of face count.

3.5.2 Setting Face Count

1. Click **Home**  > **Toolbar**  > **Configure**  > **Video process**. The Setup dialog box appears.
2. From the Video Analysis drop-down list, select **Face Count**, select the desired cameras and click **Setting**. This dialog box appears.

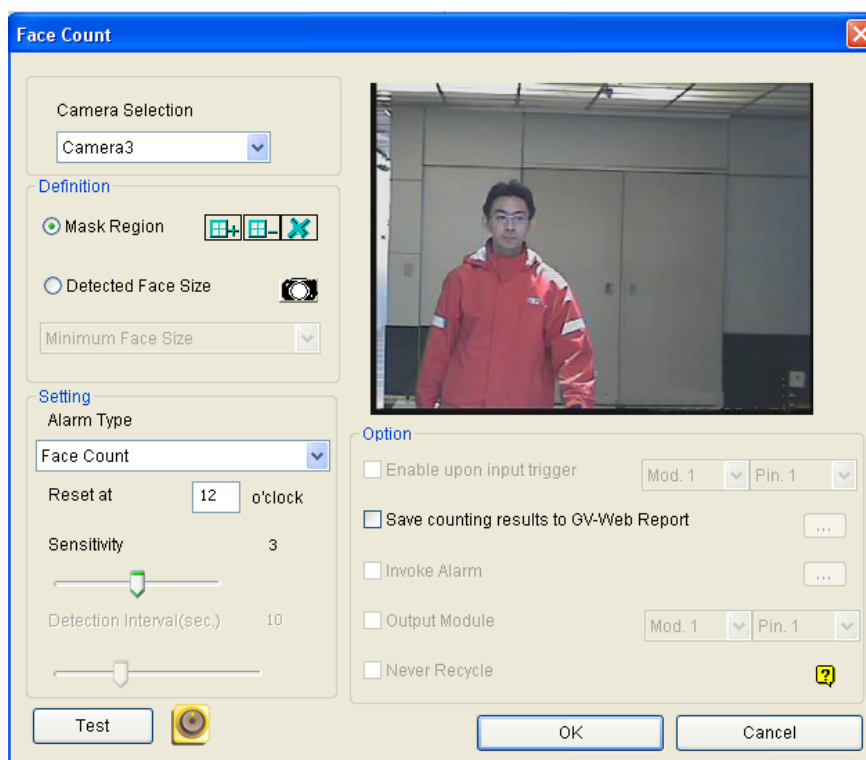



Figure 3-16

3. Under **Camera Selection**, select a camera from the drop-down list to be configured.
4. The following configurations are available:

[Definition]

- **Mask Region:** Use the mouse to outline a mask area where motion will be ignored.
- **Detected Face Size:** You can adjust the **Minimum Face Size** and the **Maximum Face Size** to instruct the system to only detect faces within that size range. Pause the live image by clicking  before configuring.

[Setting]

- **Alarm Type**
 - ⊙ **Face Count:** Counts the number of faces. The counting results are only available on the GV-Web Report. To connect to the GV-Web Report, see the **Saves counting results to GV-Web Report** option below.

- **Mask Filter:** Detects faces to invoke a computer alarm or triggers an output device.
- **Mask Filter (Inverse Alarm):** Invokes a computer alarm or triggers an output device when the system is unable to detect a face after the number of seconds specified in the **Detection Interval**.
- **Reset at:** Type a counting reset time between 0 and 23. For example, if you type 23, the number of faces counted will become zero at 23 o'clock daily.
- **Sensitivity:** Adjust the detection sensitivity by moving the slider. The higher the value the more sensitive the system is to motion. The default value is 3.
- **Detection Interval:**
 - When **Mask Filter** and **Enable Upon Input Trigger** are both selected, the **Detection Interval** slider specifies the number of seconds you want the system to detect faces when the input device is triggered.
 - When **Mask Filter (Inverse Alarm)** is selected, the system will attempt to detect the faces for the duration specified for **Detection Interval**.

[Option]

- **Enable upon input trigger:** The system will begin detecting only when the input device is triggered. Assign an input module and pin number for the device.
 - **Saves counting results to GV-Web Report:** Saves the face counting results to the GV-Web Report. Type the **Domain Name or IP Address**, **Port**, **User Name**, and **Password** of the GV-Web Report. After settings, click the **Test** button to see if the connection succeeds.
 - **Invoke Alarm:** Activates the computer sound alarm when faces are detected under **Mask Filter** or when the system is unable to detect faces under **Mask Filter (Inverse Alarm)**. Click the [...] button to designate a sound file for the computer alarm.
 - **Output Module:** Activates the output device when faces are detected under **Mask Filter** or when the system is unable to detect faces under **Mask Filter (Inverse Alarm)**. Assign an output module and pin number for the device.
 - **Never Recycle:** Prevents recorded events from being recycled when the recycle threshold is reached.
5. Click the **Test** button to see if the settings have been configured according to your preference. If you have set a detection interval, the test will only run for the number of seconds you specified.
 6. Click **OK** to apply the settings.

7. Start monitoring to run the application. The detected (counted) faces are indicated on the live view with green boxes.

Note:



1. Events triggered under **Mask Filter** or **Mask Filter (Inverse alarm)** will be recorded to the System Log for later retrieval. In the System Log, the events are recorded as **Face Count** under the **Monitor** tab (ViewLog > Toolbar > Tools > System Log).
 2. The **Face Count** results will only be saved when **Saves counting results to GV-Web Report** is selected and the GV-Web Report is connected.
 3. The counter function is not recommended to be applied in fisheye cameras.
 4. Optionally create a schedule for face count to be enabled only at the time periods specified. For details, see *Creating Schedules* in Chapter 1.
-

3.6 Face Recognition

Face Recognition integrates the facial recognition abilities of GV-Face Recognition Cameras and/or GV-AI FR for the system to distinguish detected human faces. Based on the Face Databases of the cameras / servers connected, this feature displays the names of the recognized persons on the live view, while recording the recognition events during video recording. Additionally, the recognition events recorded can at the same time be used to trigger e-mail alerts, outputs and computer alarms, run the desired applications and/or send notifications to GV-Notify mobile app upon recognizing individuals of the face groups specified or for unknown recognition events.

Note:

1. GV-Face Recognition Cameras include GV-VD8700 and GV-FD8700-FR.
 2. GV-AI FR is only supported by GV-VMS V18.1 or later.
-

When GV-Face Recognition Cameras / GV-AI FRs are connected to GV-VMS, their face databases can be managed by the VMS's Face Manager. To access the Face Manager, click **Home**  > **Toolbar**  > **Configure**  and select **Face Manager**.

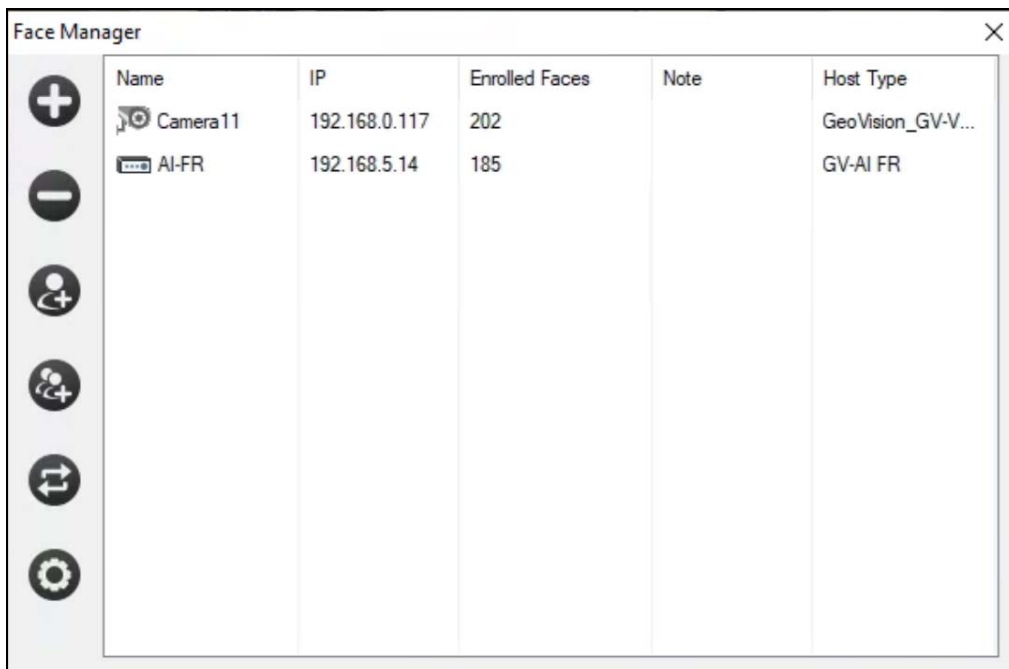



Figure 3-17

- All GV-Face Recognition Cameras connected to GV-VMS are automatically added to the Face Manager.
- For GV-AI FRs, users can manage their face databases only after adding them to the Face Manager by clicking **Add GV-AI FR** . See *Chapter 5 GV-VMS Integration* in [GV-AI FR User's Manual](#).

3.6.1 Enrolling Face Data

Prior to using Face Recognition, it is required to create the necessary recognition data via Face Enrollment — adding photos of the persons to be recognized into the Face Databases of the GV-Face Recognition Cameras and/or GV-AI FRs connected.

- Enroll faces by adding portrait photos directly into the database of the cameras / servers connected, see the steps below.
- Synchronize face data from other connected cameras / servers, see *Synchronizing Face Database* later in this section.

IMPORTANT:

1. GV-VMS directly accesses and manages the Face Database of GV-Face Recognition Cameras / GV-AI FRs, thus all changes made are done directly to their databases.
 2. Photos used as recognition data can be pictures of the persons previously taken or snapshots of the persons captured by connected cameras.
 3. All photos used for Face Enroll must meet the criteria as specified in No. 3 under [Face Recognition FAQ](#).
-

1. Select the desired GV-Face Recognition Camera / GV-AI FR on **Face Manager** and click **Face Enrollment**.
2. Click **Add**  to define a new Face ID. Alternatively, select or **Search** for an existing ID from the **Enrolled Face** list.

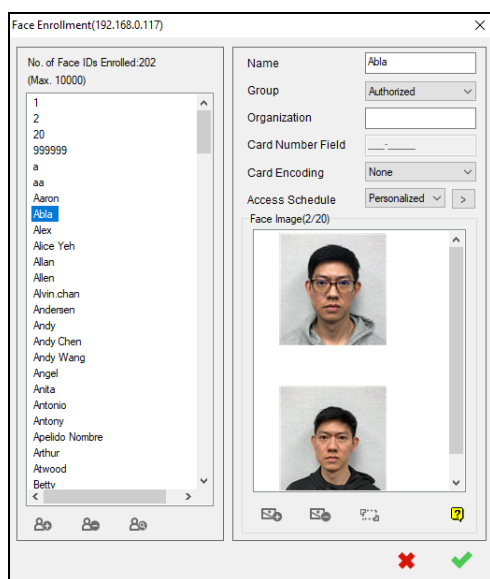





Figure 3-18



3. Click **Add**  below Face Images to add photos and/or snapshots for the Face ID selected from your local PC. Optionally crop the image added by selecting it and click **Crop Image** .
4. You can also configure the following options for the Face ID selected:
 - **Name:** Type a desired name for the Face ID.
 - **Group:** Select from a list of groups in which the Face ID shall be categorized under. This setting can be used to trigger e-mail alerts and/or output alarms when persons from a specified Group is recognized at the surveillance site. See *Setting Face Groups* and *Configuring Face Setting* later in this chapter.
 - **Organization:** Type a desired organization name for the Face ID.
 - **Card Number Field** and **Card Encoding:** Only available on GV-VMS V18.1 or later, type an access card number and select the corresponding card type from the drop-down list to pair the access card to the Face ID for face recognition-based access management. See *Integrating Face Recognition to Access Control* later in this chapter.
 - **Access Schedule:** Select a predefined schedule in which the Face ID is allowed access or select **Personalized** and click  to define an exclusive schedule for the person. To set a schedule, refer to *Defining Access Schedule* later in this chapter for details.
5. Click **OK** to save.

Note:

1. All changes made here take immediate effect on the Face Database of the GV-Face Recognition Camera or GV-AI FR selected.
 2. To batch enroll multiple faces, see *Batch Enrolling Faces and Access Cards* later in this chapter.
-

3.6.1.1 Enrolling Faces from Live View / ViewLog

Alternative to enrolling face data with photos, users can also enroll with face images captured by any cameras connected to GV-VMS. Note this function is only supported by GV-VMS V18.1 or later.

1. In Live View / ViewLog, click **Snapshot**  at the bottom of a desired channel and select **Face Enroll**  and click . The Quick Enroll window appears.

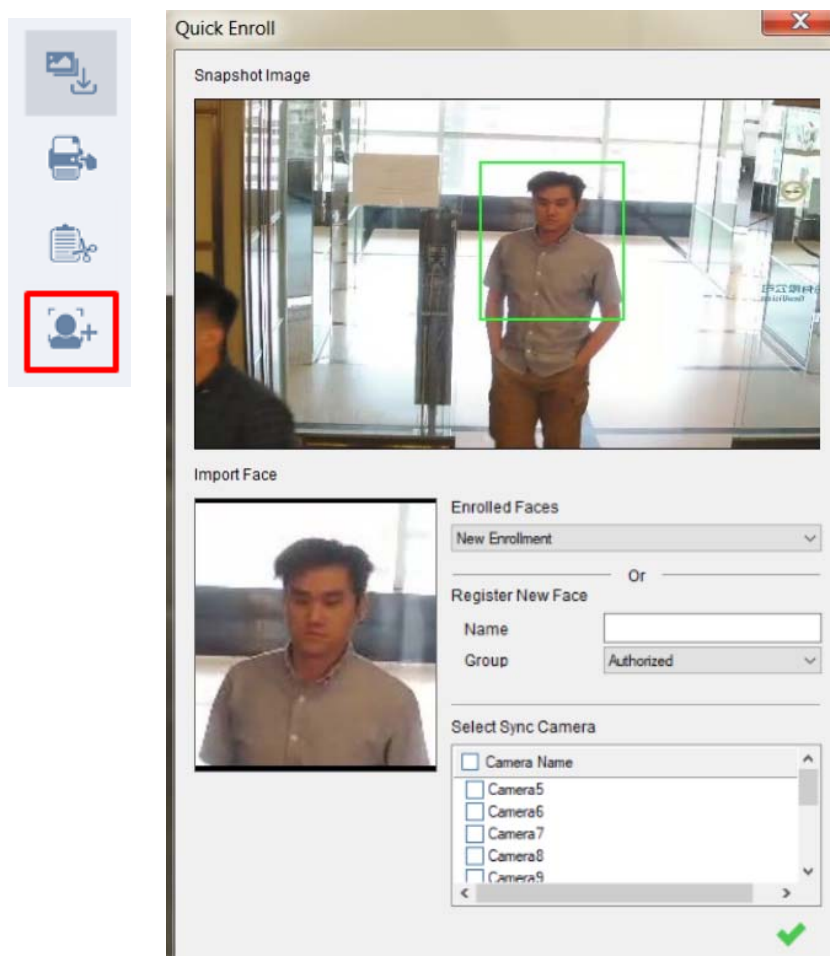



Figure 3-19

2. Click and drag on the image to highlight the face you want to enroll as a **snapshot**.
3. Select **New Enrollment**, type the desired name under **Register New Face** to create a new Face ID and select a **Face Group** to add it under. Otherwise select an existing one for the face image to be added to.
4. Select the desired GV-Face Recognition Camera / GV-FR Server for the face enrollment under **Select Sync Camera**.
5. Click  to save.

3.6.2 Setting Face Groups

Only supported by GV-VMS V18.1 or alter, to add and/or edit the Face Groups of a GV-Face Recognition Camera / GV-AI FR connected, select the desired camera / server on **Face Manager** and click **Group Setup** .

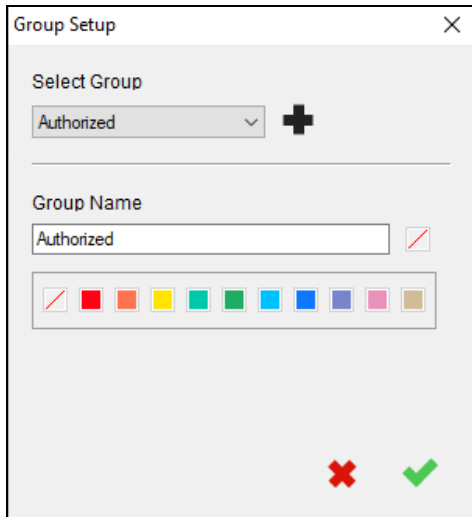



Figure 3-20

To add a face group, click **Add** .

To edit the name of a face group, select the group from the **Select Group** drop-down list and edit its name under **Group Name**. Optionally select a color for highlighting the recognition events of the face group selected on the **Face ID** window. See *Face ID — Live Recognition Profiles* later in this chapter.

Once finished, click the  to save.

3.6.3 Synchronizing Face Database

To synchronize the face databases among two or more GV-Face Recognition Cameras or among two or more GV-AI FRs, click **Face Database Synchronization**  on **Face Manager**. The following window appears.

Note: Face databases of GV-Face Recognition Cameras cannot be synchronized with those of GV-AI FRs.

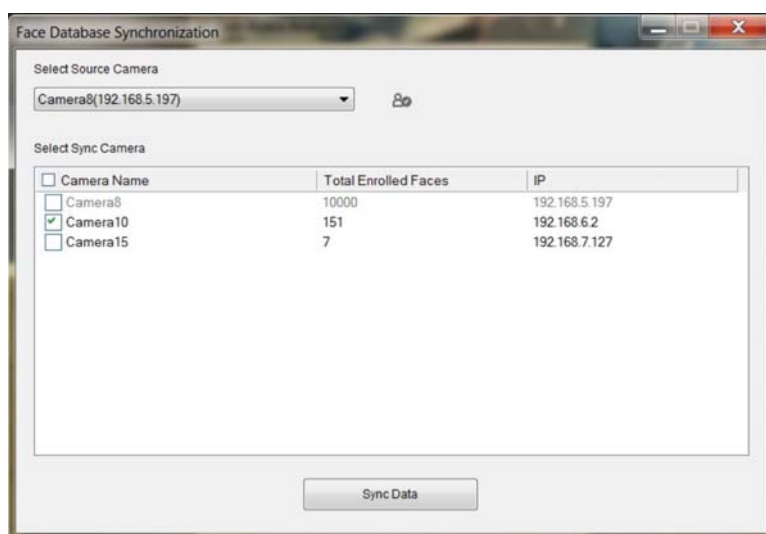



Figure 3-21

- **Select Source Camera:** Select the camera you want to synchronize from.
- **Select Sync Faces** : Only available on GV-VMS V18.1 or later, click to select the Face IDs that you want to synchronize with.
- **Select Sync Camera:** Select the cameras that you want to be synchronized.
- **Sync Data:** Click to start synchronizing.





3.6.4 Defining Access Schedule

Access Schedules are used to specify the time periods in which specific persons (Face ID) are allowed or denied access of from Monday to Sunday. Whenever a person is recognized outside of his/her allowed schedule, a schedule alert is recorded, which can be used to trigger e-mail alerts, outputs and computer alarms, run the desired applications and/or send notifications to GV-Notify mobile app.

The Access schedule can be set in three steps:

- **Step 1 Setting 24-hour Schedules**
Define the minutes and hours a person is allowed / denied access of in a day.
- **Step 2 Setting Weekly Schedules**
Define the days a person is allowed / denied access of in a week.
- **Step 3 Assigning Access Schedules**
Assign the defined schedules to the desired persons in Face Enrollment.

3.6.4.1 Step 1: Setting 24-hour Schedules

Before creating weekly schedules, you need to first define a number of desired 24-hour schedules that can be used to prepare the weekly schedules. On **Face Manager (Home**  **> Toolbar**  **> Configure**  **> Face Manager**), click **Configure**  and select **24-hour Schedule**. In this window, up to 254 24-hour schedules can be defined, with two default schedules for “Full Access” and “Deny Access.”

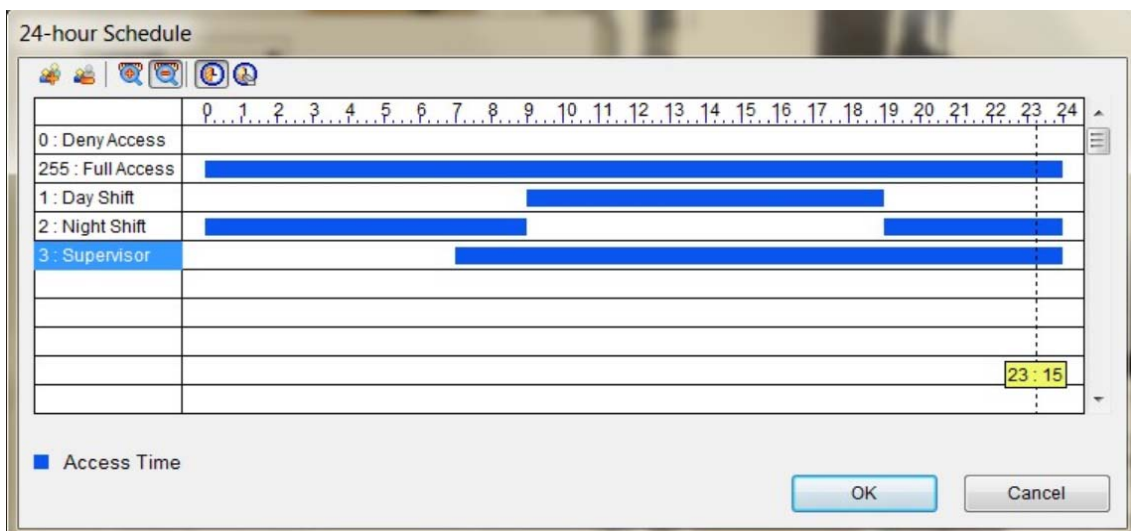





Figure 3-22

1. Click the **Add** button . An ID number ascending from the lowest existing ID will be automatically generated. Type a desired name for the new schedule, e.g. **Day Shift** and click **OK**.

2. Click the **Add Access Time** button . Then drag the mouse on the timeline to specify the time periods of allowed access, e.g. **from 09:00 to 19:00**.
3. Repeat Steps 1 to 3 to create multiple schedules if needed, e.g. for **Night Shift from 00:00 to 09:00 and 19:00 to 24:00** and for **Supervisor from 07:00 to 24:00**.
4. To remove time periods of allowed access, click the **Delete Access Time** button . Then drag the mouse over the periods that you want to remove.
5. Click **OK** to save the changes.

3.6.4.2 Step 2: Setting Weekly Schedules

Once the desired 24-hour schedules are set, click **Configure**  on **Face Manager** and select **Weekly Schedule**. In this window, up to 254 weekly schedules can be defined, with two default schedules for “Full Access” and “Deny Access.”

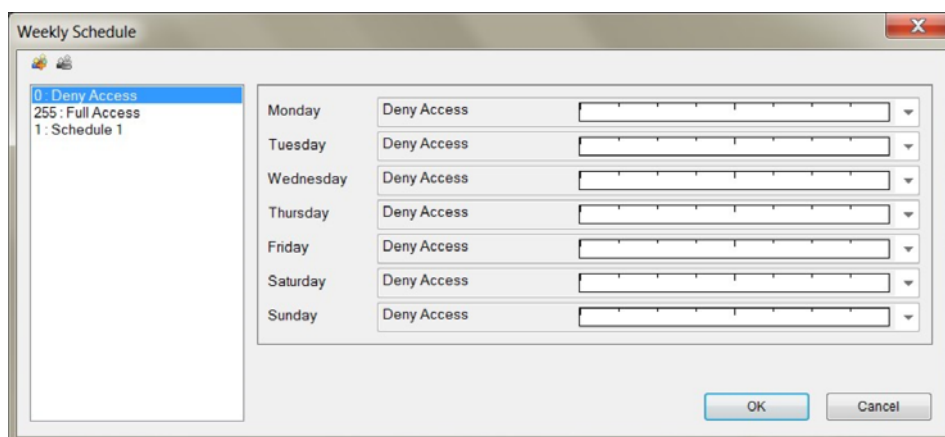



Figure 3-23

1. Click the **Add** button . An ID number ascending from the lowest existing ID will be automatically generated. Type a desired name for the new schedule, e.g. **Rotation** and click **OK**.

2. Select the desired schedules for **Monday** to **Sunday**, predefined from *Step 1* earlier in this section, in each of the respective drop-down lists, as exemplified below.

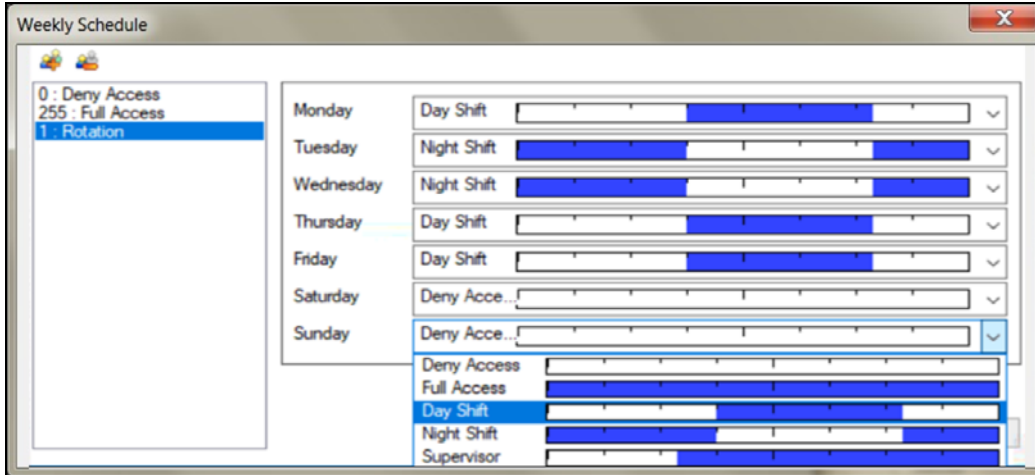



Figure 3-24

3. Repeat Steps 1 to 3 to create multiple schedules if needed, e.g. for **Daytime-only** and **Weekend-only** access.
4. To delete schedules, select the schedule to be deleted and click the **Remove** button .
5. Click **OK** to save the changes.

3.6.4.3 Step 3: Assigning Access Schedules

Once the weekly schedules are set, select the desired GV-Face Recognition Camera / GV-AI FR on **Face Manager** and click **Face Enrollment**. Select or search for a desired Face ID and select a schedule in the **Access Schedule** drop-down list.

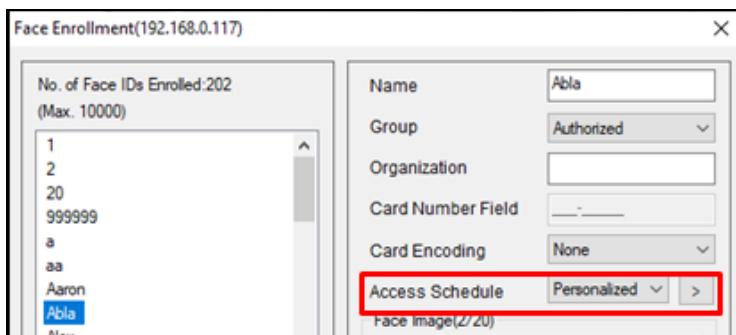





Figure 3-25

Once the Access Schedules are assigned, turn on monitoring of the camera channel to start access monitoring based on the schedules.

3.6.5 Setting Recognition Alerts

In this section, you can use Schedule Alerts, Unknown Alerts or the Recognition Events of a specified Group, e.g. Unauthorized, to send e-mail alerts, trigger outputs and computer alarms, run the desired applications and/or send notifications to GV-Notify mobile app.

On **Face Manager (Home**  **> Toolbar**  **> Configure**  **> Face Manager**), click **Configure**  and select **Camera and Alert Settings**. This window appears.

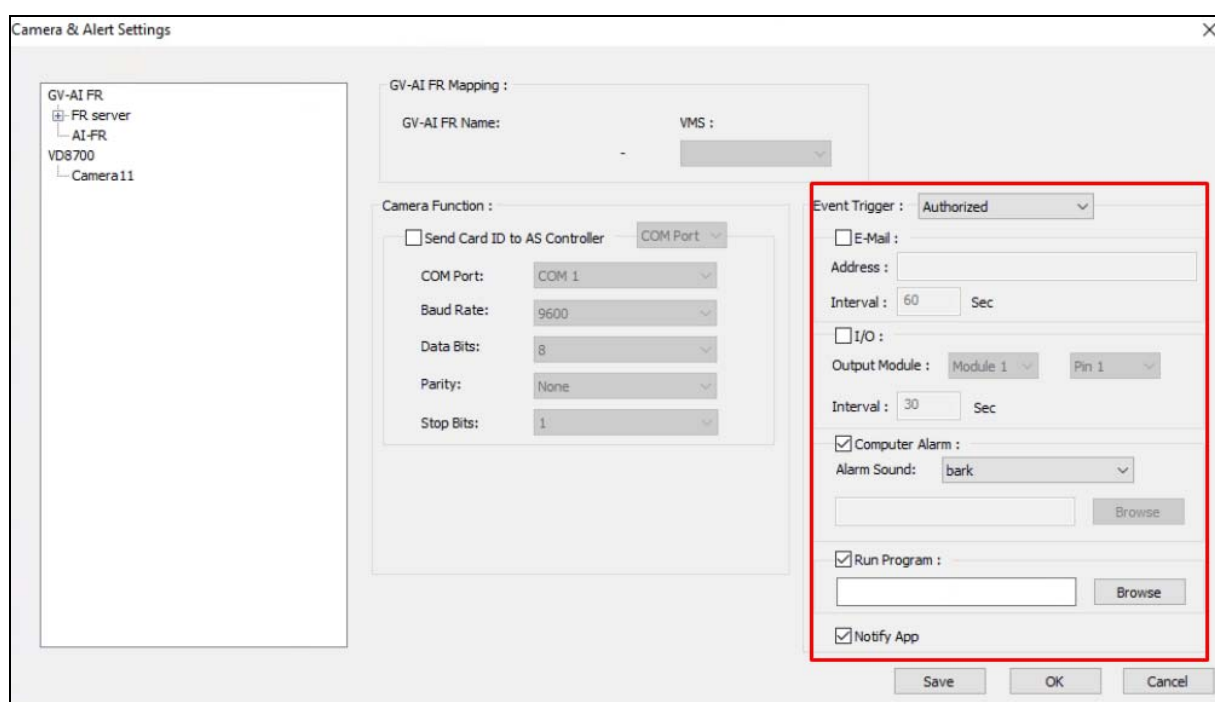

Figure 3-26





Select the GV-Face Recognition Camera or GV-AI FR for which you want to set recognition alerts for.

- **Event Trigger:** Select Schedule Alert, Unknown Alert or the Group of Face ID that the alerts set should be triggered for. For details on using Schedule Alerts, refer to *Defining Access Schedule* earlier in this chapter.
- ⦿ For **E-Mail**, set the minimum time **Interval** allowed, from 0 to 3600 seconds, in between each e-mail notification.
- ⦿ For **I/O**, a GV-I/O Box needs to be connected to GV-VMS for the I/O function to work, select the desired **Output Module** and **Pin** number.
- ⦿ For **Computer Alarm**, only available on GV-VMS V18.1 or later, select the desired alarm from the **Alarm Sound** drop-down list or click **Browse** to select the desired audio file from your PC to be used as the alarm sound.

- For **Run Program**, only available on GV-VMS V18.1 or later, click **Browse** to select a desired program to be executed upon trigger.
- For **Notify App**, only available on GV-VMS V18.1 or later, see [GV-Cloud Center User's Manual](#) for details.

Note: Make sure the e-mail and I/O functions are configured properly before use. For details, see *Setting Up Email Notification* and *Setting I/O Devices* in Chapters 1 and 6, respectively.

3.6.6 Configuring Face Recognition Database

To configure the database of face recognition events, including storage path of the snapshots and log files of recognition events, click **Configure**  on **Face Manager (Home**  > **Toolbar**  > **Configure**  > **Face Manager**) and select **DB Setting**. This window appears.

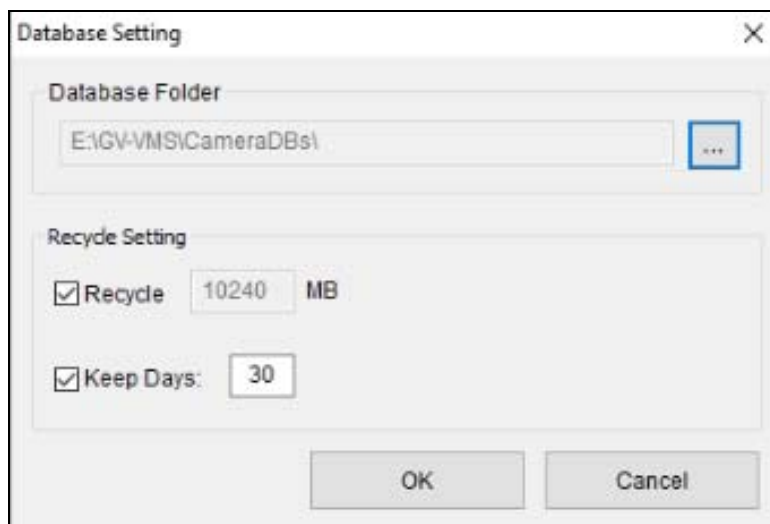







Figure 3-27

- **Database Folder:** Click the Browse button  to modify the storage path for the snapshots and log files of recorded Recognition Events.
- **Recycle Setting:** Enable to recycle the data in the Database Folder upon reaching the volume threshold set.
- **Keep Days:** Type the desired number of days that data in the Database Folder should be kept for, from 1 to 999.

3.6.7 Backing up Face Database

Only available on GV-VMS V18.1 or later, to back up the face database of a GV-Face Recognition Camera / GV-AI FR, click **Configure**  on **Face Manager (Home**  > **Toolbar**  > **Configure**  > **Face Manager**, select **Backup Data From...** and select a desired host by its IP address. You can now save the database on your local PC as an *.fdb file.

To import the face database into a GV-Face Recognition Camera / GV-AI FR, **Configure**  on **Face Manager**, select **Import Backup Data To...** and select a desired host by its IP address.

IMPORTANT: When a face database is imported into a host, it replaces all of the original face data contained within.

3.6.8 Face ID — Live Recognition Profiles

Only available on GV-VMS V18.1 or later, the Face ID feature allows users to view the simplified info of real-time face recognition events.

Note: This function only works when at least one GV-Face Recognition Camera / GV-AI FR is recording.

To access **Face ID**, click **Home** , **Toolbar** , select **Tools**  and click **Face ID**. The following window appears.

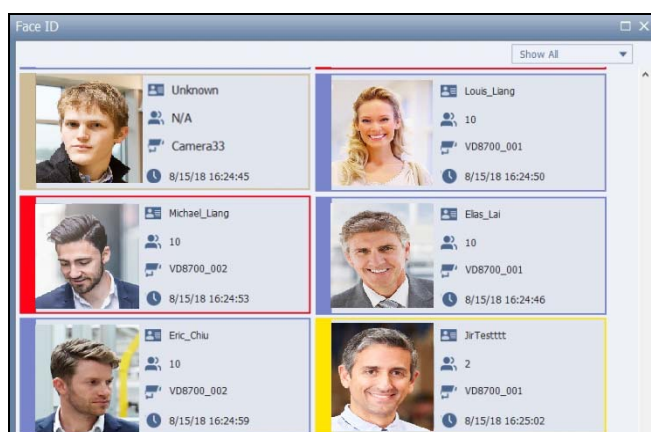





Figure 3-28

Each real-time face recognition event is displayed with a snapshot, the name of the person, the face group the person is under, the camera channel and the time of recognition, and is highlighted by the color assigned to the face group. For assigning the desired colors to face groups, see *Setting Face Groups* earlier in this chapter.

3.6.9 Viewing and Searching for Face Recognition Events

During recording, all recognition events, along with recognition snapshots, recognition time, and schedule alerts, when applicable, are recorded in an event log during video recording. To view **Face Recognition** in recorded videos, click **ViewLog**  > **Toolbar**  > **Tools**  > **Face Recognition**. This window appears.

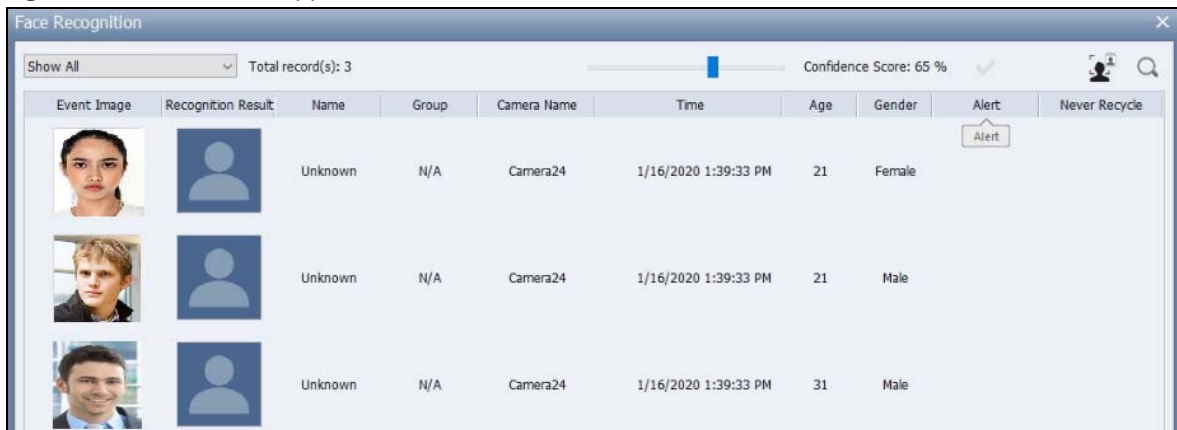



Figure 3-29

- **Show All:** Select **Show All**, **Show Identified Persons Only** or **Show Unknown Persons Only** to filter the recognition events displayed.
- **Event Image:** Display the captured Snapshot of the recognition event. Double-click the Snapshot to see the recording of the recognition event in ViewLog.
- **Recognition Result:** Display the photo of the Face ID the person is recognized as.
- **Name:** Display the Name of the individual recognized. Written as “Unknown” if unrecognizable.
- **Group:** Display the Group the recognized person is categorized under in the Face Database.
- **Camera Name:** Display the Channel in which the recognition event was recorded.
- **Time:** Display the Time of the recognition event.
- **Age:** Only available on GV-VMS V18.1 or later, display the estimated age of the person recognized.
- **Gender:** Only available on GV-VMS V18.1 or later, display the gender that the person is recognized as.
- **Alert:** Record Schedule Alerts when the recognition event recorded is outside of the person’s (Face ID) allowed access schedule.

Searching by Face Images

Only available on GV-VMS V18.1 or later, click  to search for recognition events by using a face image from your PC. Optionally drag the **Confidence Score** to adjust the minimum level of the similarity of the search results as compared to the face image used.

Alternatively, right-click on the snapshot of a desired recognition event and click **Face Search** to use it to search for recognition events.

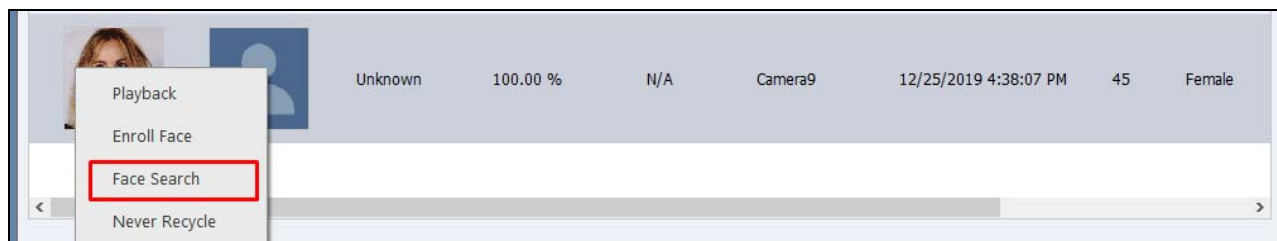



Figure 3-30

Searching by Query

Click **Query**  to filter and search for recognition events by time, camera channel, face group, age, gender, alert events and/or keyword search.

Note: The Name search in Query functions is a keyword search and is case-sensitive.

3.6.10 Tracking Recognized Faces

Tracking of recognized faces can be displayed on the E-Map when there are multiple cameras with synchronized Face Databases.

To display Face Tracking, refer to the following for the related settings:

- **Step 1 Synchronizing Face Database**

To synchronize Face Databases, see *Synchronizing Face Database* earlier in this chapter.

- **Step 2 Creating E-Map(s)**

To create E-Map(s) and add the camera, see *Creating an E-Map* in Chapter 8.

- **Step 3 Turning on Monitoring and Viewing**

Turn on monitoring for all of the camera channels of GV-Face Recognition Cameras / GV-AI FRs where the face may be tracked and drag the E-map from the Content List to the live view screen.

Once all the related settings are set, you will see arrows indicating the movements of recognized persons on the E-Map, with

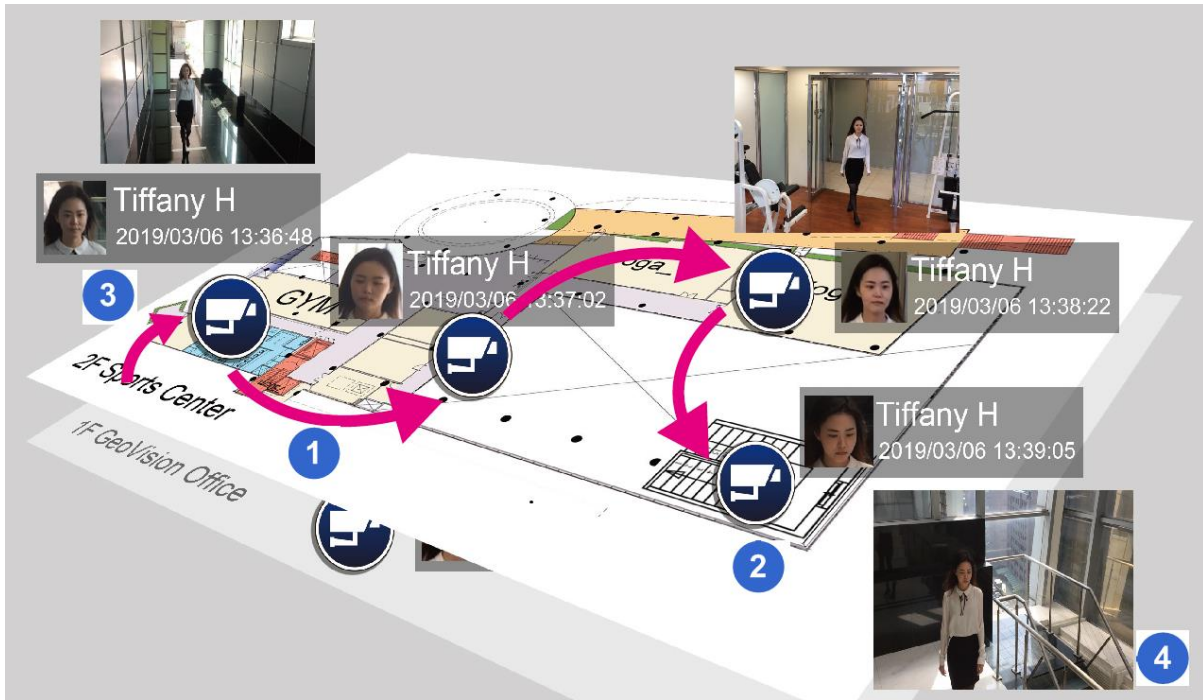



Figure 3-31

No.	Name	Description
1	Face Tracking	Display the direction of movement of the individual recognized.
2	Latest Recognition Site	The end point of the Face Tracking arrow indicates the surveillance site (camera channel) where the recognized individual was last seen.
3	Previous Recognition Site	The initial point of the Face Tracking arrow indicates the surveillance site (camera channel) where the recognized individual was previously seen.
4	Recognition Event	Display a live image of the Recognition Event.

Adjusting the Display Mode on E-Map

To adjust the display mode of the recognition events on E-Map(s), click **Tools**  and select **Face Recognition** for the following options:

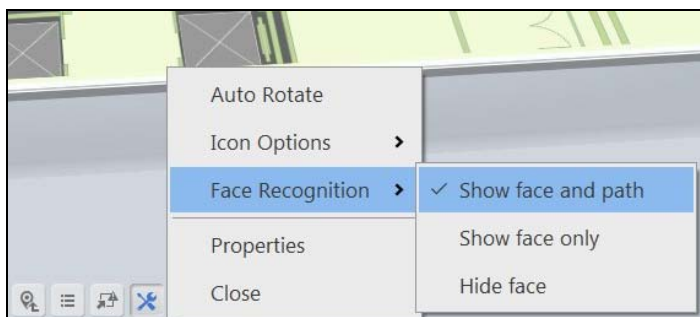

Figure 3-32

- **Show face and path:** Selected by default, display both Face Tracking and the Recognition Events on the E-Map.
- **Show face only:** Display only the Recognition Events on the E-Map.
- **Hide face:** Do not display any Recognition Events and Face Tracking on the E-Map.

Configuring Face Tracking

For an increased accuracy, you can modify the interval setting of **Face Tracking** based on your surveillance needs.

1. In Content List of Live view, click **Configure**  > **General Setting**. This window appears.

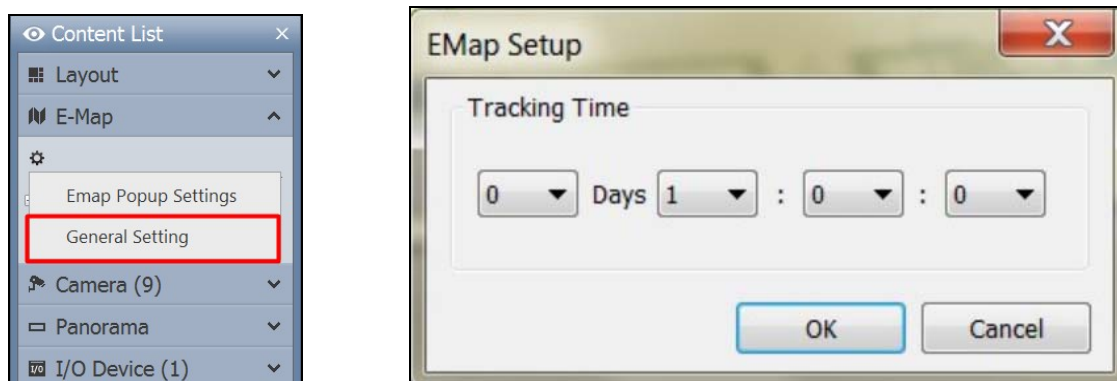

Figure 3-33

2. Under **Tracking Time**, select the days (0~31), hours (0~23), minutes (0~59) and seconds (0~59) to define the time interval in which Face Tracking is effective for. Face Tracking will not be displayed for any subsequent Recognition Events occurring beyond the set Tracking Time.
3. Click **OK** to save the changes.

3.6.11 Integrating Face Recognition to Access Control





Only available on GV-VMS V18.1 or later, VMS extends the face recognition feature of connected cameras by converting recognized faces into access card data for access control management. Prior to the integration, make sure the required controller(s) and access cards have both been properly configured on your access control system, e.g. GV-ASManager.

To configure the controller and access cards, to be paired with Face IDs, see *Adding Controllers* and *Setting Cards*, respectively, in Chapter 4 of [GV-ASManager User's Manual](#).

3.6.11.1 Pairing Face IDs with Access Cards

Face IDs of GV-Face Recognition Cameras / GV-AI FRs can be paired with GV-AS ID Cards / Key Fobs or 3rd-party smart cards to be used for access control regulated by GV-ASManager

To pair Face IDs with access cards, follow the steps below.

3. On **Face Manager (Home**  **> Toolbar**  **> Configure**  **> Face Manager**), click **Face Enrollment** .
4. Select a Face ID, type the **Card Number** to be paired with and select its encoding type from the **Card Encoding** drop-down list.

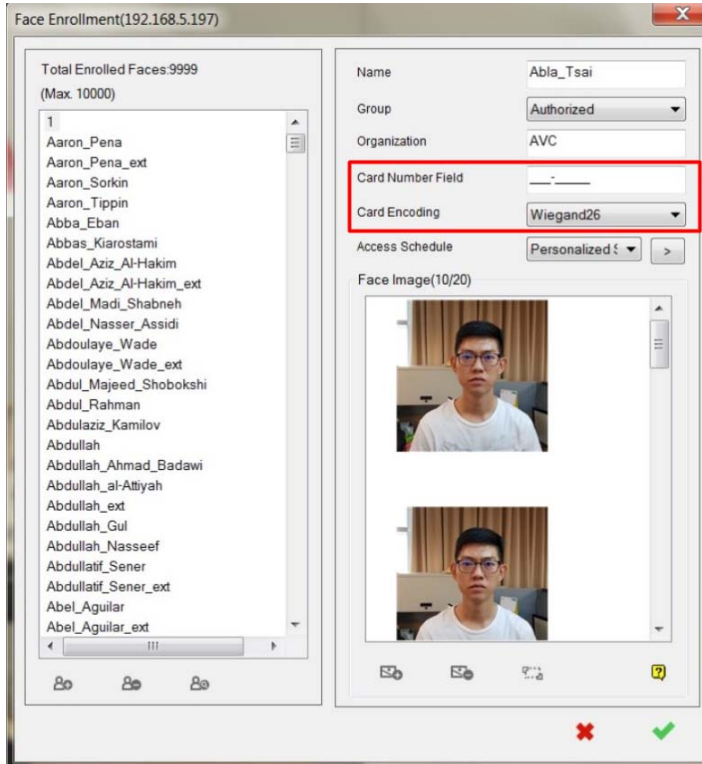

Figure 3-34

5. Click  to save.

Note: To batch enroll multiple access cards and/or import from GV-ASManager, see *Batch Enrolling Faces and Access Cards* later in this chapter.

3.6.11.2 Connecting Controller to GV-VMS

For GV-VMS to send the paired card number to the connected controller upon face recognition, the controller must be properly connected, which can be done through one of the following two methods:

- **COM Port**

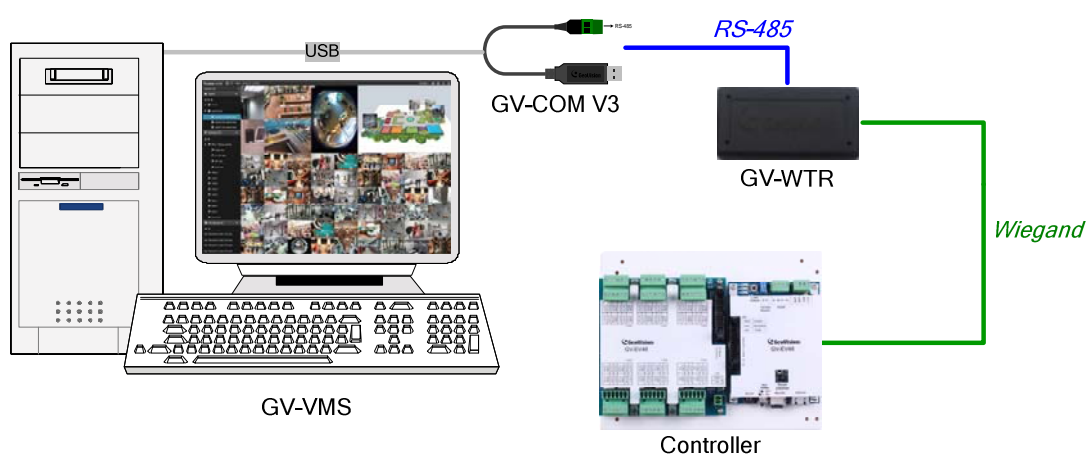

Figure 3-35





1. Connect [GV-COM V3](#) to a USB port of the PC running GV-VMS.
2. Connect [GV-WTR](#) to GV-COM V3 using its RS-485 wires.
3. Connect GV-WTR to the controller using its Wiegand wires.

- **TCP/IP**

Connect the controller to the same network as your GV-VMS.

Sending Card Number to Controller by Face ID

After the controller is successfully connected to the GV-VMS, configure the necessary settings according to the type of connection established.

1. In **Face Manager** (Home  > **Toolbar**  > **Configure**  > **Face Manager**), click **Configure**  and select **Camera and Alert Settings**.
2. Select the desired camera and enable **Send Card ID to AS Controller**. Then configure the necessary settings based on the type of connection used.

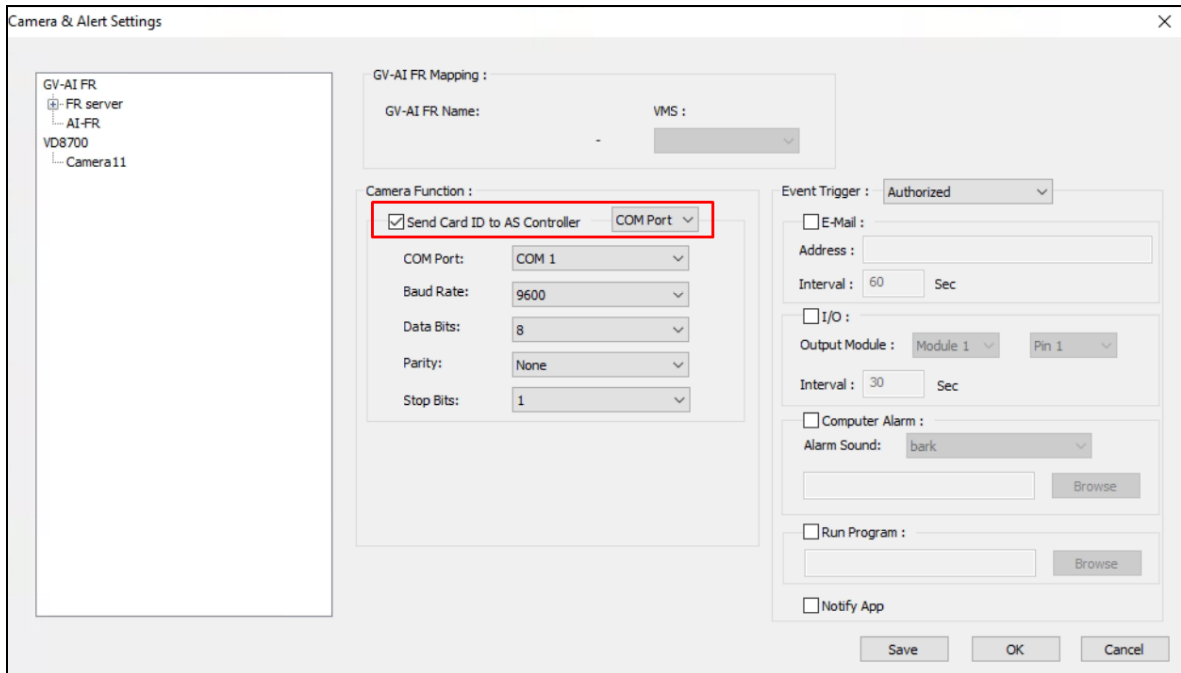

Figure 3-36

[COM Port]

- **COM Port:** Check the COM port number of the GV-COM V3 connected to the GV-VMS in **Device Manager** and select from the drop-down list accordingly. For details, see [GV-COM V3 Installation Guide](#).
- Keep the default values of **Baud Rate**, **Data Bits**, **Parity** and **Stop Bits** unless they've been changed manually.

[TCP/IP]

- **IP:** Type the IP address of the controller under the same LAN as the GV-VMS.

3.6.12 Batch Enrolling Faces and Access Cards

Only available on GV-VMS V18.1 or later, the batch enrolling feature of Face Manager allows users to import a large quantity of face images and access card data to a connected GV-Face Recognition Camera / GV-AI FR at once.

Batch Enrolling Faces Only

To enroll multiple face photos, save all of the face images to the same folder on your PC and rename them as exemplified below:

[N]<Face ID Name>[G]<Group No. - 1>[P]<Image No. - 1>.jpg

For example, [N]John[G]0[P]0.jpg, [N]John[G]0[P]1.jpg, [N]John[G]0[P]2.jpg

The above image files will be added to Face ID **John**, as the **first**, **second** and **third** images, with the ID being categorized under **Group 1**.

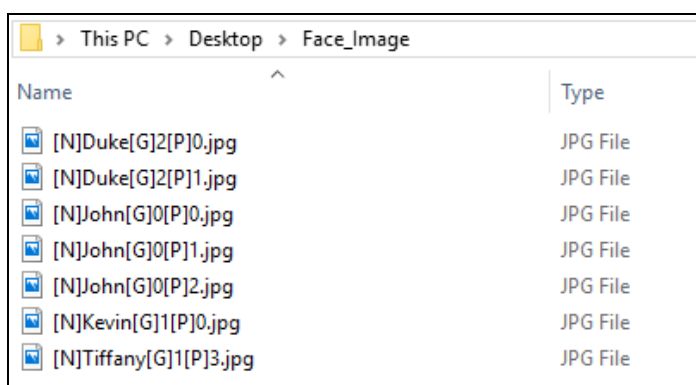





Figure 3-37

Once all the face images are named properly and saved under the same folder, right-click on the device you want them to be batch enrolled into on **Face Manager (Home**  **> Toolbar**  **> Configure**  **> Face Manager)** and click **Batch import from Face Images** to locate and select the folder.

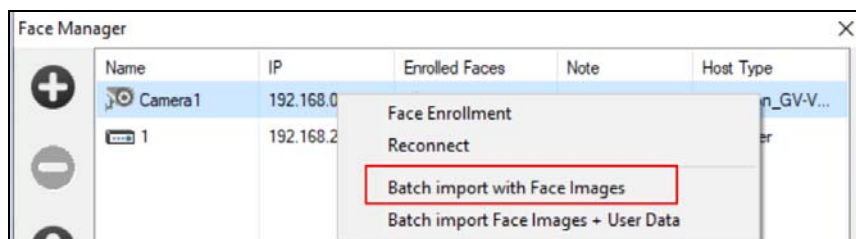

Figure 3-38

Note:

1. <Group No. – 1> indicates the desired group number minus one.
2. <Image No. – 1> indicates the order of the images minus one.
3. All photos used for face enrollment must meet the criteria as specified in [GV-Face Recognition Camera FAQ](#).

Batch Enrolling Faces + Cards

To enroll access card data along with multiple face photos from GV-ASManager to GV-Face Recognition Camera / GV-AI FR simultaneously, follow the steps below:

Note: Before batch enrolling user data and photos from GV-ASManager, make sure of the following:

- A. The Display Names of users on GV-ASManager, which will be used as Face ID names, must not contain any spaces.
- B. Photos of users on GV-ASManager must meet the criteria as specified in [GV-Face Recognition Camera FAQ](#).

1. From the **Card List**  of GV-ASWeb, make sure the proper card data are contained within, namely *Card Number*, *Card Code*, *User* and *Photo*, then click **Export** and select **TXT** > **This Page**.

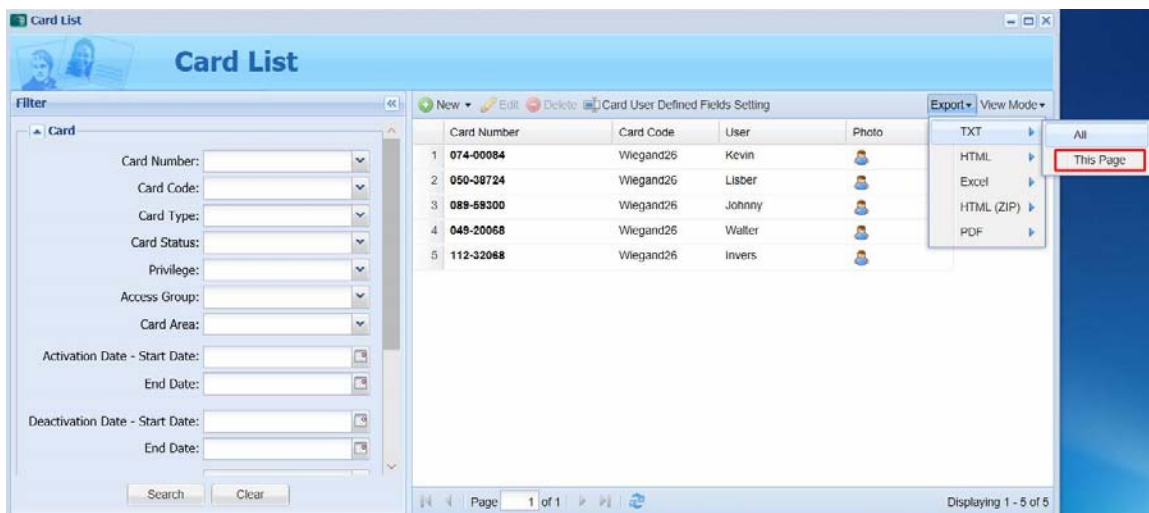

Figure 3-39

- A. For the Card List to contain the proper data, open **ASWeb Field Configuration** (under **Tools** on GV-ASManager), click the **Card List** tab and select *Card Number*, *Card Code*, *User* and *Photo*.

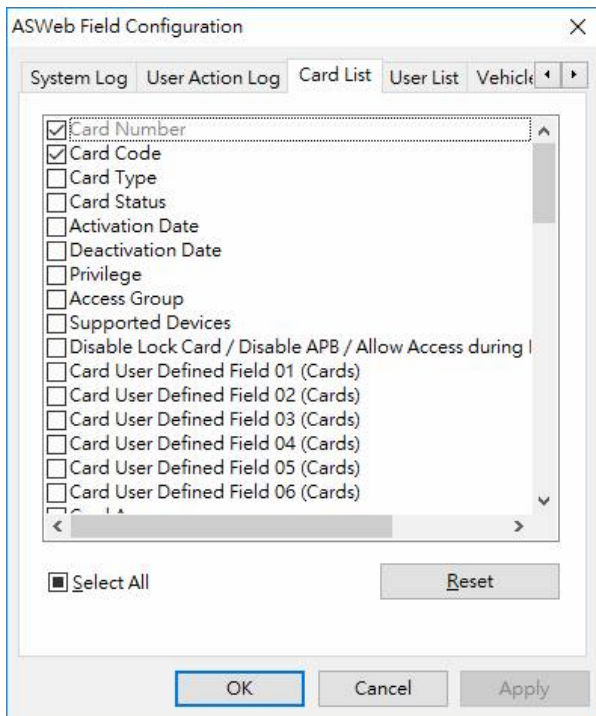

Figure 3-40

- B. In the **Card List**, select to display the fields of **Card Number**, **Card Code**, **User** and **Photo** by clicking one of the arrow buttons and deselect all other fields.

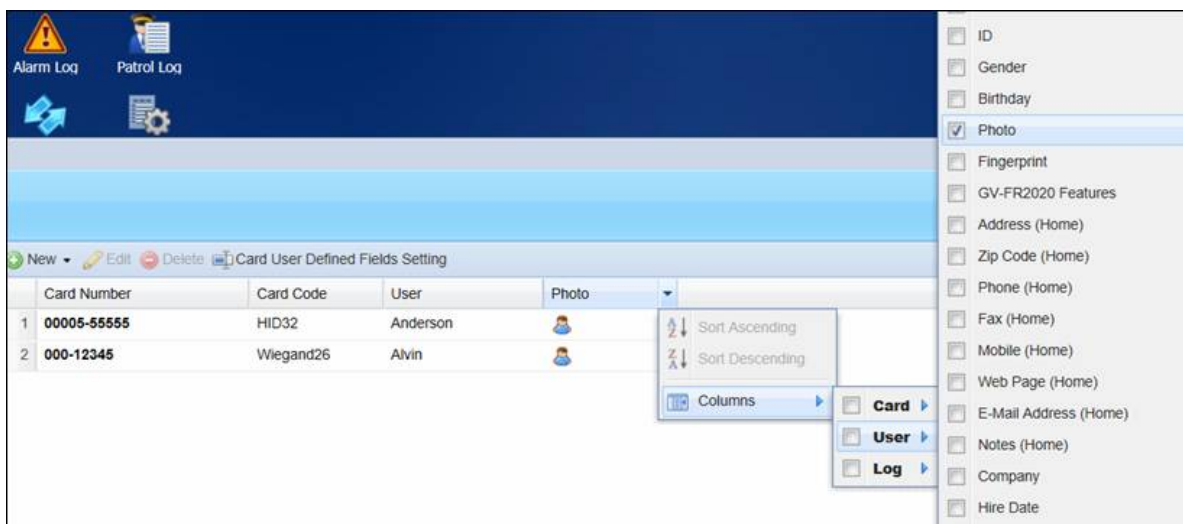

Figure 3-41



2. Save the exported TXT file, exemplified below, under a specific folder.

```

File Edit Format View Help
"074-00084", "Wiegand26", "Kevin", "00015_Kevin.jpg"
"050-38724", "Wiegand26", "Lisber", "00018_Lisber.jpg"
"089-59300", "Wiegand26", "Johnny", "00020_Johnny.jpg"
"049-20068", "Wiegand26", "Walter", "00023_Walter.jpg"
"112-32068", "Wiegand26", "Invers", "00024_Invers.jpg"

```

Figure 3-42

3. Copy the photos of the users to be enrolled from the GV-ASManager directory (default: \\ASManager\Photo) and save them under the same folder as the TXT file.
4. Once all the face images are saved within the same folder as the TXT file, right-click on the device you want them to be batch enrolled into on **Face Manager (Home  > Toolbar  > Configure  > Face Manager)** and click **Batch import Faces Images + User Data** to locate and select the folder.

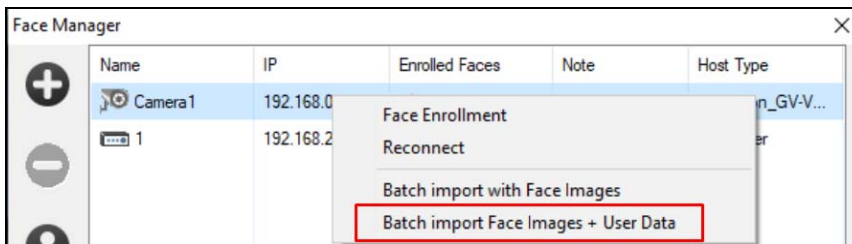





Figure 3-43

3.7 Face Detection by Camera

Only available on GV-VMS V18.1 or later, specifically designed for GV-Face Detection (FD) Cameras, the Face Detection feature of GV-VMS allows users to easily track, record and search for all of the face detection events by these cameras, within the parameters set. For an introduction to GV-FD cameras, click [here](#).

3.7.1 Configuring for FD Cameras

1. Click **Home**  > **Toolbar**  > **Configure**  and select **Video Process**.
2. In the Setup dialog box, select **IPCVA** in the Video Analysis drop-down list, select the channel(s) from which you want to track and record face detection events and click **Setting**.

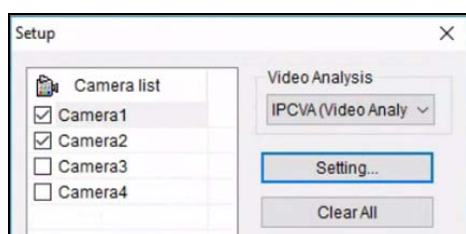

Figure 3-44

3. Select the desired channel from the drop-down list at the top and enable **Face Detection**.

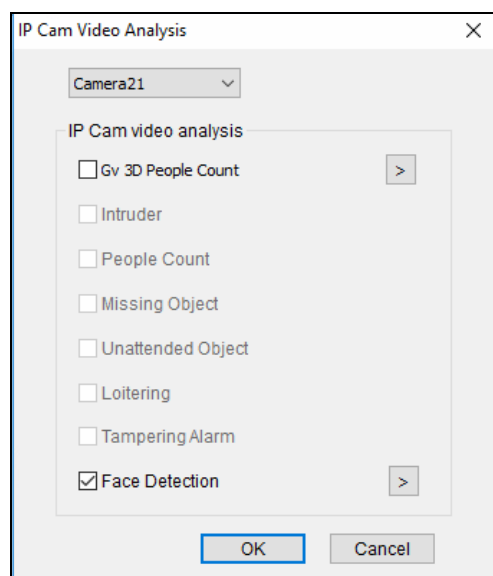

Figure 3-45

- Optionally click  next to **Face Detection** to and enable the following options:

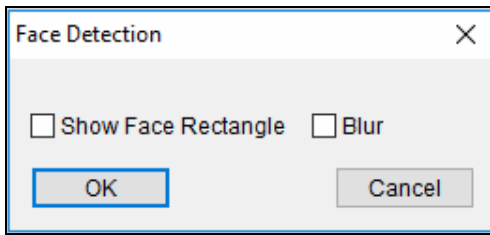

Figure 3-46

- **Show Face Rectangle:** Highlights detected faces upon face detection.
- **Blur:** Censors all faces tracked and recorded during face detection.

- Click **OK** and start monitoring for the channels of GV-Face Detection Cameras.

3.7.2 Face List — Live Face Detection



To view real-time face detection events tracked and recorded by GV-VMS, click **Home**  > **Toolbar**  > **Tools**  > **Face List**. This window appears.



Figure 3-47

Each face detection event is represented by a snapshot image, along with the camera channel and the time in which the event occurred. Double-click on a snapshot to play back the video recording of that particular face detection event.

Note: All face detection events are also recorded as unknown face recognition events on GV-VMS. To search for face detection events, see *Viewing and Searching for Face Recognition Events* earlier in this chapter.



3.8 Privacy Mask Protection

The Privacy Mask can block out sensitive areas from view, covering the areas with black boxes in both live view and recorded clips. This feature is ideal for locations with displays, keyboard sequences (e.g. passwords), and for anywhere else you don't want sensitive information visible.

You can also choose to retrieve the block-out areas during playback. The retrievable areas will be protected by password.

Note: No motion will be detected in the areas set up with Privacy Mask. To have Privacy Mask and motion detection functions together, you need to use built-in motion detection function of the camera instead (Home > Toolbar > Configure > Video Process > IPCVA > Setting > Motion Detection), as well as enabling motion detection on the camera.

3.8.1 Setting a Privacy Mask

1. Click **Home**  > **Toolbar**  > **Configure**  > **Video process**. The Setup dialog box appears.
2. From the Video Analysis drop-down list, select **Privacy Mask Setup**, select the desired cameras, and then click **Setting**. This dialog box appears.

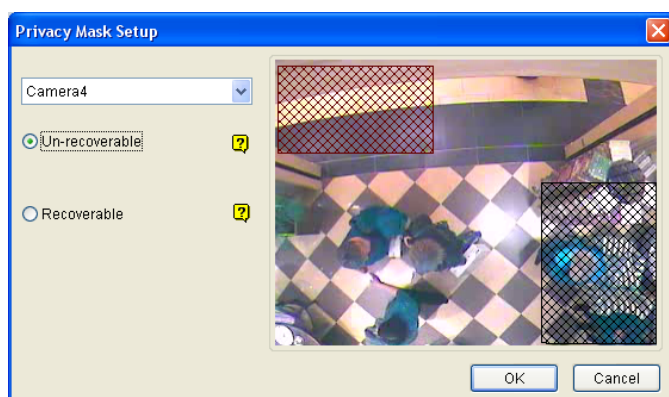

Figure 3-32

3. Select a camera from the drop-down list.
4. Select Un-recoverable and/or Recoverable.
 - **Un-recoverable:** The block-out area(s) will not be retrievable in the recorded clips.
 - **Recoverable:** The block-out area(s) will be retrievable with password protection.

5. Drag on the area(s) where you want to block out on the image. You will be prompted to click **Add** to save the setting. The Un-recoverable region is marked in black, while the recoverable region is shown in red.
6. Click **OK** to apply the settings.

Note: Optionally create a schedule for Privacy Mask to be enabled only at the time periods specified. For details, see *Creating Schedules* in Chapter 1.

3.8.2 Granting Access Privileges to Recoverable Areas

By default, only a Supervisor account is granted access to see the block-out areas on recorded videos. To grant access rights to Power Users and Users, follow the steps below.

1. Click the login user button **admin** on the main screen, select **Password Setup > Local Account Edit**. The Local Account Edit dialog box appears.
2. Select one account, click the **Privacy Mask** tab, select **Restore Recoverable Video** and select the camera to grant the privilege.

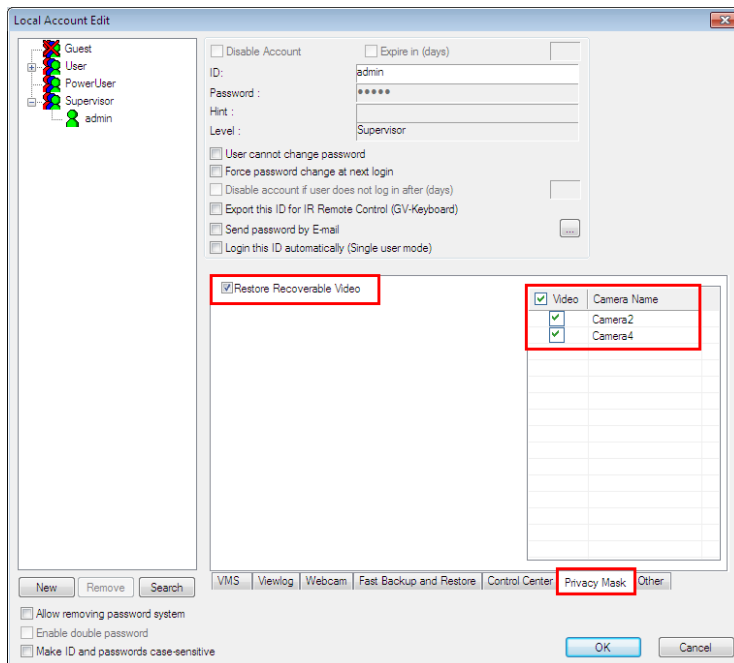

Figure 3-33

Note: If you open the event files (*.avi) directly from local disks, the valid ID and password are also required to access the block-out areas. For details on retrieving the block-out areas in the exported files, see *Merging and Exporting Video* in Chapter 4.

3.9 Panorama View

A panorama view joins multiple camera images together and allows you to monitor a large area in one view. The cameras selected for the panorama view will keep the recording in original format. Up to 4 sets of panorama views can be created. There are two ways to create a panorama view:

- Stitch camera images together by overlapping and matching reference points
- Use the Easy Mode to place camera images next to each other with no overlapping

In Content List of Live view, select **Panorama > Configure** . The Panorama View Setup dialog box appears.

3.9.1 The Main Window

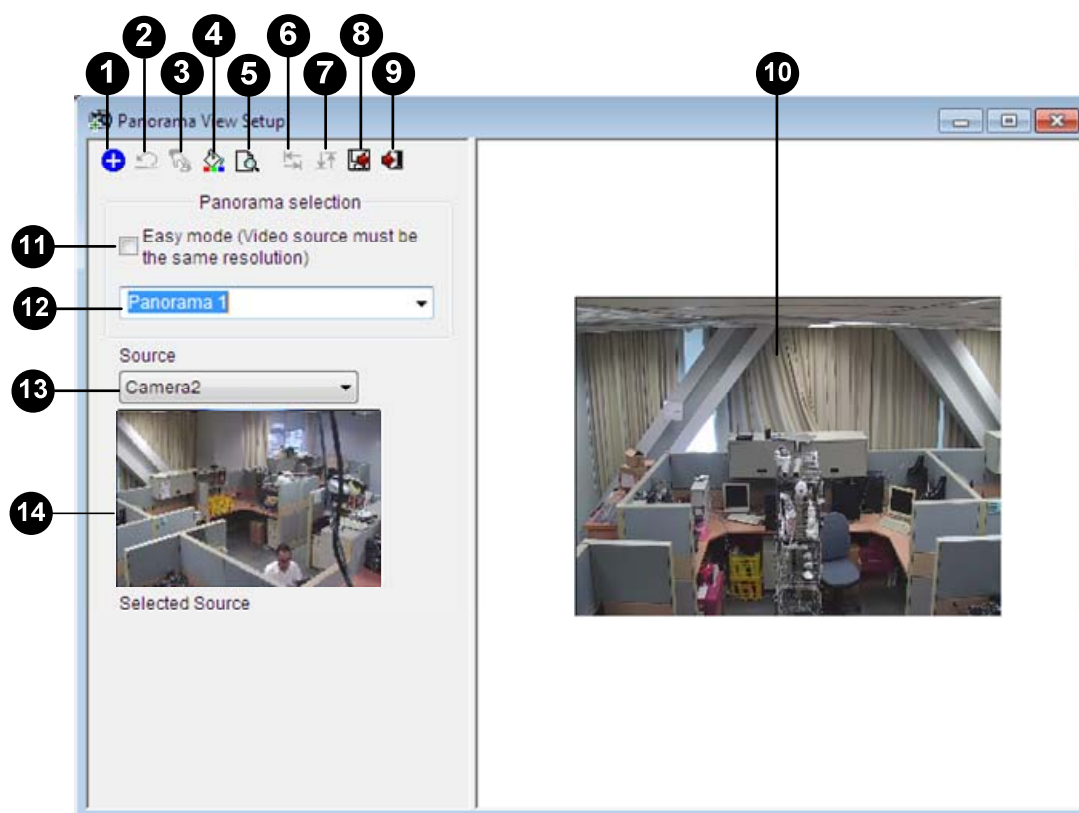

Figure 3-34

The controls on the Panorama View Setup dialog box:

No.	Name	Description
1	Add	Adds an image for automatic splicing.
2	Undo	Cancels the settings.
3	Manual Setting	Manually splices the images together.
4	Blending	Makes the spliced images seamless.
5	Demo	Displays the setup procedure.
6	Left / Right	Place the selected image to the left or right of the previous image.
7	Top / Bottom	Place the selected image on the top or bottom of the previous image.
8	Save Before Exit	Saves the created panorama view and closes the dialog box.
9	Exit	Closes the dialog box.
10	Preview Window	Displays the selected source image or the spliced images.
11	Easy Mode	Places camera views next to each other with no overlaps.
12	Panorama Selection	Selects the panorama set for the images to be spliced together. Clicks again to rename the panorama set.
13	Source	Selects the source image to be spliced.
14	Selected Source	Displays the selected image.

3.9.2 Stitching a Panorama View with Overlapping Areas

To stitch images from different cameras together, follow these steps:

1. Select one panorama set (No. 12, Figure 3-34) from the drop-down list. If you want to rename the selected panorama set, type the name in the field.
2. Select one camera from the Source drop-down list and click **Add**. The image will be the reference image on which other images will be sliced.

3. Select another camera from the Source drop-down list (No. 13, Figure 3-34) and click **Manual Setting** (No.3, Figure 3-34). This dialog box appears.

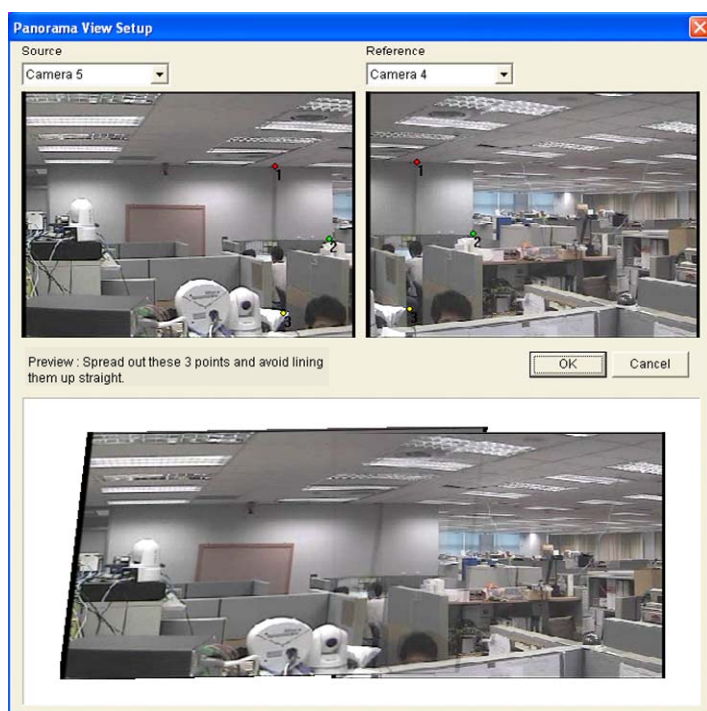

Figure 3-35

4. From the Source drop-down list, select one camera as the Source image to be stitched with the Reference image.
5. To stitch the two images together, click on a significant point in the Reference image and then look for the same point in the Source image. A dialog box of point selection will prompt you to confirm. You need to set up 3 points for stitching.

Note: For the best result, position the points in the overlapping areas on both images. Avoid placing the points in a cluster or lining them up straight.

6. The resulting image is displayed in the Preview window. If satisfied with the result, click **OK** to exit the setup dialog box. If not, re-enter the 3 points for stitching.
7. If you want to stitch a third image or more, click **Manual Setting** and repeat Steps 3 to 5 multiple times.
8. When you finish stitching images, click the **Save Before Exit** button (No.6, Figure 3-34) to save the created panorama view before exiting the Panorama View Setup dialog box.

Note: The resolution of the images to be stitched will be reduced to 320 x 240. A panorama view has a resolution limit of 1920 x 1080. Once the limit is reached, you cannot stitch more images to the created panorama view.

- This panorama view is saved to the Panorama category in the Content List.

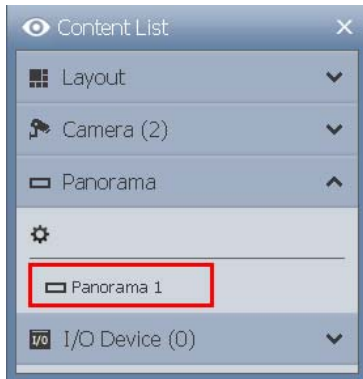

Figure 3-36

- Drag the created panorama view to the live view grid for display.

3.9.3 Easy Mode with No Overlapping Areas

When you have multiple camera views covering areas right next to each other with no overlaps, the Easy Mode allows you to simply place camera views together.

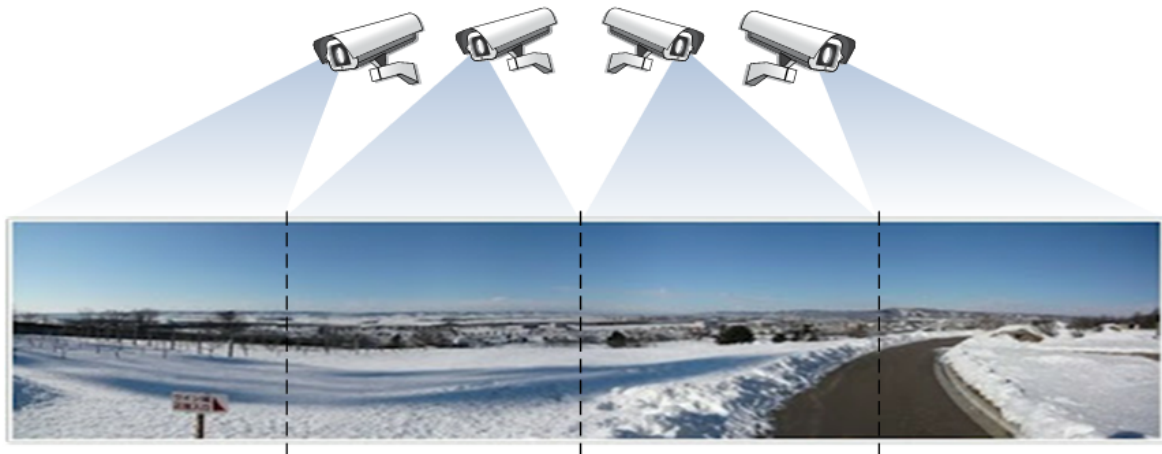



Figure 3-37

- Select **Easy Mode (Video source must be of the same resolution)** (No. 11, Figure 3-34).

- Use the **Source** drop-down list (No. 13, Figure 3-34) to select the first camera view to be placed in the panorama and click the **Add**  button. The first camera view is added to the Preview Window.

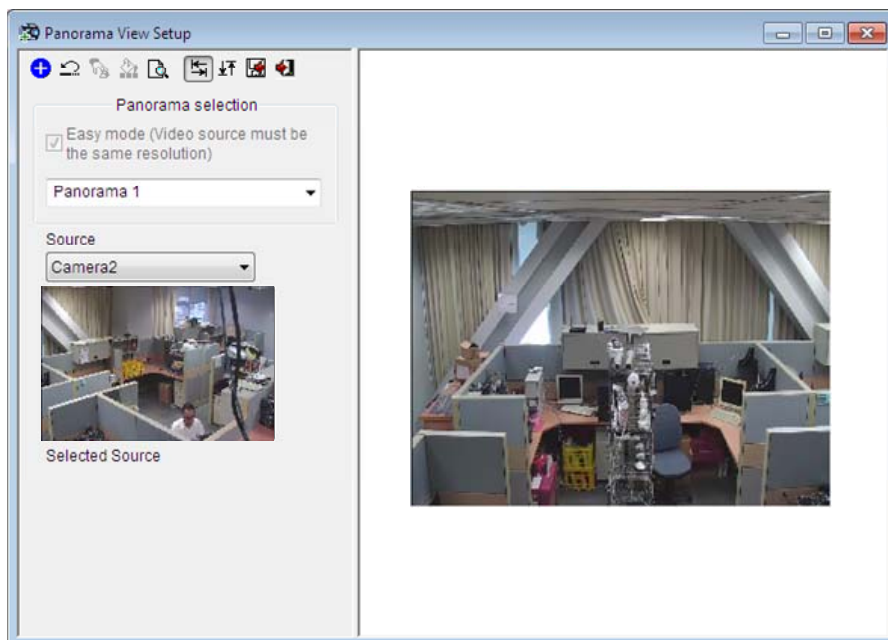



Figure 3-37

- To add a second camera view, select the camera from the **Source** drop-down list.
- To place the camera view on the left or right of the first camera view, click the  icon and select to place the second view on the **Left** or **Right** of the first view.

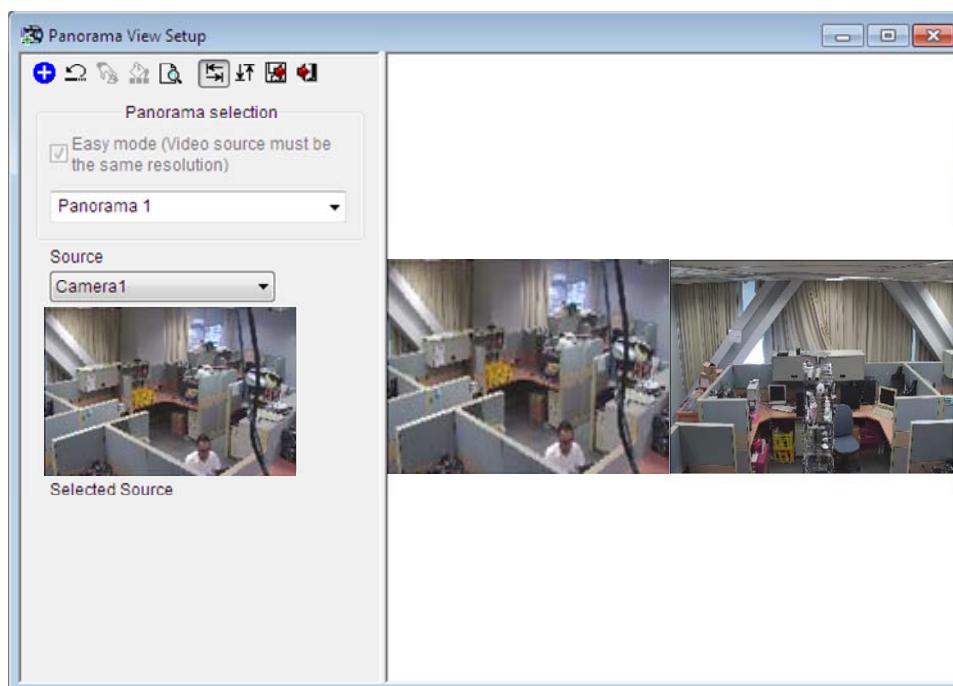





Figure 3-38

5. To place the camera view above or below the first camera view, click the  icon and select to place the second view on the **Top** or **Bottom** of the first view.
6. Repeat the steps for any additional cameras.

Note: You will only be able to add additional cameras next to the last camera view added. For example, when adding a third camera, you can only use the direction buttons   in relation to the second camera. You will not be able to go back and select the first camera.

7. When you finish stitching images, click the **Save Before Exit** button  before exiting.
8. This panorama view is saved to the Panorama category in the Content List (Figure 3-36).
9. Drag the created panorama view to the live view grid for display.

3.9.4 Accessing a Panorama View

Drag the configured panorama from the Content List (Figure 3-36) to the live view. The panorama view is displayed on the main screen.



Figure 3-39

Right-click the panorama view to have these options:



- **Snapshot:** Save the current panorama view as an image file.
- **Zoom:** Put the cursor on the live view and scroll your mouse to zoom the live view.

3.10 Video Defogging

Smoky environments and bad weather, such as rain, snow or fog, all affect image quality and reduce scene visibility. This feature helps to enhance image quality for live viewing.

Note:

1. This function takes high CPU and memory usage. Make sure at least 1 GB of RAM is installed on your system.
 2. **Defogging** is not supported when **Heat Map** is enabled.
-

1. Click **Home**  > **Toolbar**  > **Configure**  > **Video process**. The Setup dialog box appears.
2. From the Video Analysis drop-down list, select **Defog**, select the desired cameras, and click **Setting**. This dialog box appears.

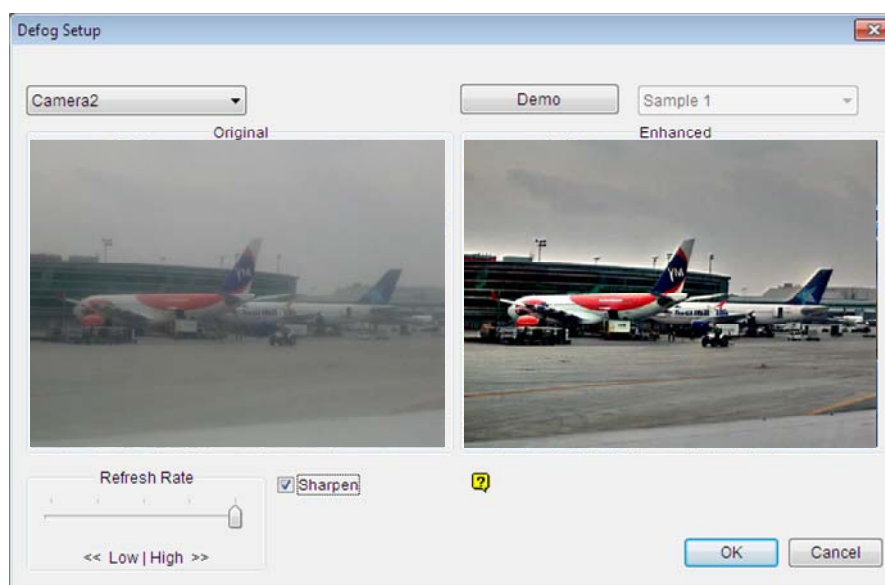

Figure 3-40

3. Use the drop-down list to select a camera.
4. When the image enhancement is enabled, the system load will increase. Adjust the **Refresh rate** by moving the slider bar to optimize system performance.
5. If you want to view the demonstration of this function, click the **Demo** button.

Note:

1. This function only applies to live view and does not affect the recorded video. To apply defogging to recorded videos during playback, on **ViewLog**, right-click the desired image > **Effects** > **Defog**.
 2. For better image quality, it is recommended to change the streaming to single stream before you enable the video analysis effect. This effect does not support On Demand Display for automatic adjustment of live video resolution in single-channel division.
 1. Optionally create a schedule for video defogging to be enabled only at the time periods specified. For details, see *Creating Schedules* in Chapter 1.
-

3.11 Video Stabilization

Images from a shaky camera are jittery or blurry. This feature helps to reduce camera shake, leaving you with clear and steady images.

Note:

1. This function takes high CPU and memory usage. Make sure at least 1 GB of RAM is installed on your system
 2. **Stabilization** is not supported when **Heat Map** is enabled.
-

1. Click **Home**  > **Toolbar**  > **Configure**  > **Video process**. The Setup dialog box appears.
2. From the Video Analysis drop-down list, select **Stabilizer**, select the desired cameras, and click **Setting**. This dialog box appears.

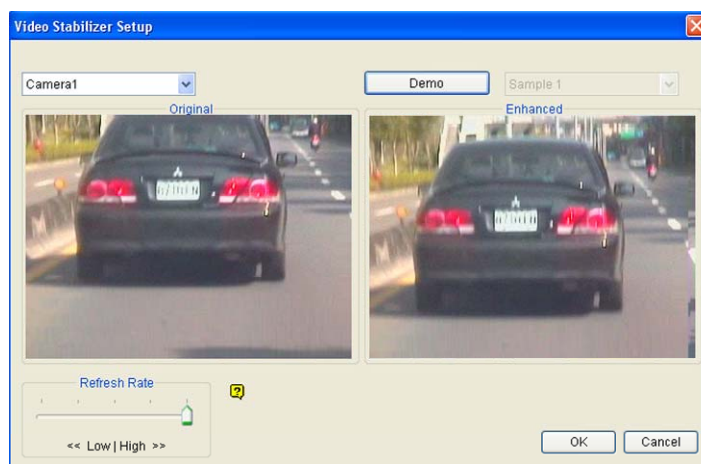

Figure 3-41

3. Use the drop-down list to select one camera. The enhanced view is shown on the right.
4. When the image enhancement is enabled, the system load will increase. Adjust the **Refresh rate** by moving the slider to optimize system performance.
5. If you want to view the demonstration of this function, click the **Demo** button.

Note:

3. This function only applies to live view and does not affect the recorded video. To apply stabilization to recorded videos during playback, on **ViewLog**, right-click the desired image > **Effects > Stabilizer**.
4. For better image quality, it is recommended to change the streaming to single stream before you enable video stabilization. This effect does not support On Demand Display for automatic adjustment of live video resolution in single-channel division.
5. Optionally create a schedule for stabilization to be enabled only at the time periods specified. For details, see *Creating Schedules* in Chapter 1.

3.12 Wide Angle Lens Dewarping

Camera images can sometimes appear curved toward the edges of the view. This feature helps correct distortion towards the edge of the camera view.

1. Click **Home**  > **Toolbar**  > **Configure**  > **Camera Install**. The IP Device Setup dialog box appears.

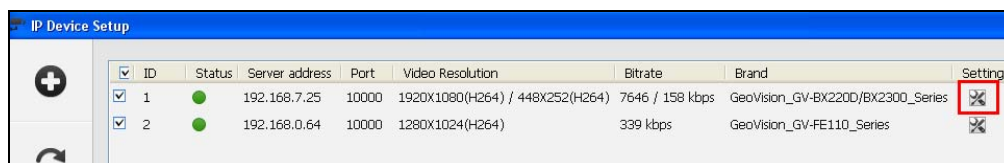

Figure 3-42

2. Click **Settings** . This dialog box appears.

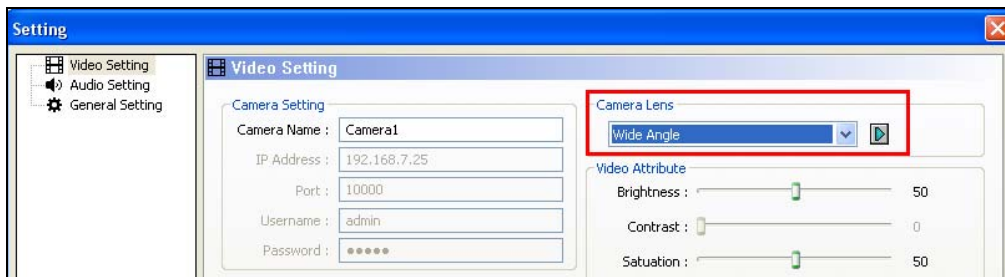



Figure 3-43

3. Use the **Camera Lens** drop-down list to select **Wide Angle**
4. Click the  button. This dialog box appears.

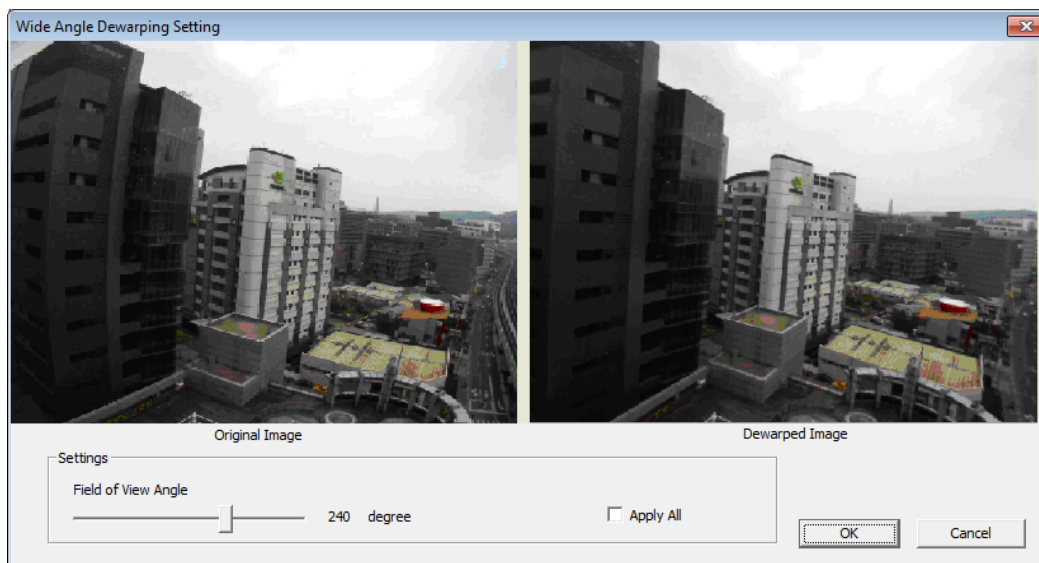

Figure 3-44

5. Move the slider to adjust the degree of warping. The adjusted view is shown on the right.
6. Click **OK**. The dewarping is immediately applied on the live view.



Note:

1. This function only applies to live view and does not affect the recorded video. To apply stabilization to recorded videos during playback, on **ViewLog**, right-click the desire image > **Effects > Wide angle lens dewarping**.
2. If dual-stream IP channels are applied, for better image quality, it is recommended to change the streaming to single stream before you enable wide angle lens dewarping. This effect does not support On Demand Display for automatic adjustment of live video resolution in single-channel division.

3.13 Crowd Detection

Crowd detection is used to generate an alert when a crowd of people gathers in a specified area and exceeds the defined time threshold.

Note: Up to 16 cameras can be configured for this application.

1. Click **Home**  > **Toolbar**  > **Configure**  > **Video process**. The Setup dialog box appears.
2. From the Video Analysis drop-down list, select **Crowd Detection**, select the desired cameras, and then click **Setting**. This dialog box appears.

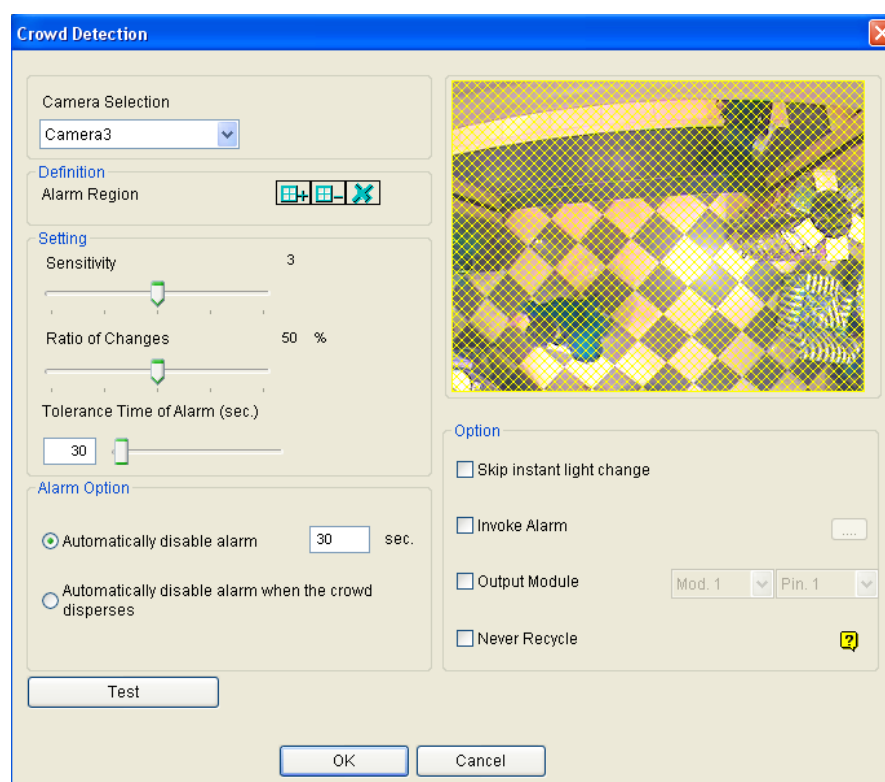





Figure 3-45

3. Select a camera from the Camera Selection drop-down list.
4. By default the whole camera view is set to be the alarm region. Click the  button to clear the default setting. Click the  button to freely draw the alarm region. To cancel the previously drawn area, click the  button.
5. To adjust the Crowd Detection sensitivity, move the **Sensitivity** slider. The higher the sensitivity value, the more sensitive the system is to detecting crowds.

6. To define the minimum ratio of change (in the alarm region) for the alarm to be activated, move the **Ratio of Changes** slider to set a value. The smaller the ratio of changes, the more sensitive the system is to the changes in the camera view.
7. To define the minimum time that a crowd needs to stay for the alarm to be activated. Use the **Tolerance Time of Alarm** slider to specify a value or type a number in the blank.
8. Optionally configure the following settings:
 - **Automatically disable alarm:** Triggered alarms are automatically disabled after the specified time (seconds). The default setting is **30** seconds.
 - **Automatically disable alarm when the crowd disperses:** Triggered alarms are immediately disabled when no crowds are detected.
 - **Skip Instant Light Change:** Ignores sudden illumination changes to minimize false alarms. For example, light switches can cause illumination changes suddenly. With the option selected, the system will ignore significant illumination changes without triggering the alarm and continue monitoring. See the **Note** below for possible risk.
 - **Invoke Alarm:** Enables the computer alarm when an assemblage is detected. Click the [...] button next to the option to assign a .wav sound file.
 - **Output Module:** Activates the output device when a crowd is detected. Select this option and use the drop-down list to assign an installed output module and a pin number.
 - **Never Recycle:** Prevents the system from recycling the event files of crowd detection when the recycle threshold is reached.
9. You can click **Test** to test your settings. When an assemblage is detected in the camera view, a flashing box will appear on its location for warning. If an assemblage cannot be detected, decrease **Ratio of Changes** to increase the system sensitivity for detection.
10. Click **OK** to apply the settings.
11. Start monitoring to run the application. The detected crowd is indicated on the live view with blinking red and green boxes.

When a crowd of people gathers in the alarm region for the specified time, its location will be highlighted on live view, the selected alarm or output will be activated, and the event will be recorded as **Crowd Detection** in System Log for later retrieval.

Note:

1. For the **Skip Instant Light Change** option:
 - When the option is selected, you may be subject to the risk that the system will not generate an alert whenever the lens of the camera is covered by malice.
 - This option is not recommended for infrared cameras.
 2. Optionally create a schedule for crowd detection to be enabled only at the time periods specified. For details, see *Creating Schedules* in Chapter 1.
-



To manually stop all triggered alerts, click the **Tools** button  on the triggered channel, select **Reset Alert** and select **Crowd Detection**.

- **Reset Alert:** Disables and resets the triggered alert. After the alert is reset if the crowd remains gathering over the specified tolerance time, the system will still detect it as a crowd gathering and keep generating alert.

3.14 Advanced Scene Change Detection

The Advanced Scene Change Detection detects any changes of scene, viewing angle or focus clearness made by malice in both indoor and outdoor environments.

Note: Up to 16 cameras can be configured for this application.

1. Click **Home**  > **Toolbar**  > **Configure**  > **Video process**. The Setup dialog box appears.
2. From the Video Analysis drop-down list, select **Advanced Scene Change Detection**, select the desired cameras, and then click **Setting**. This dialog box appears.

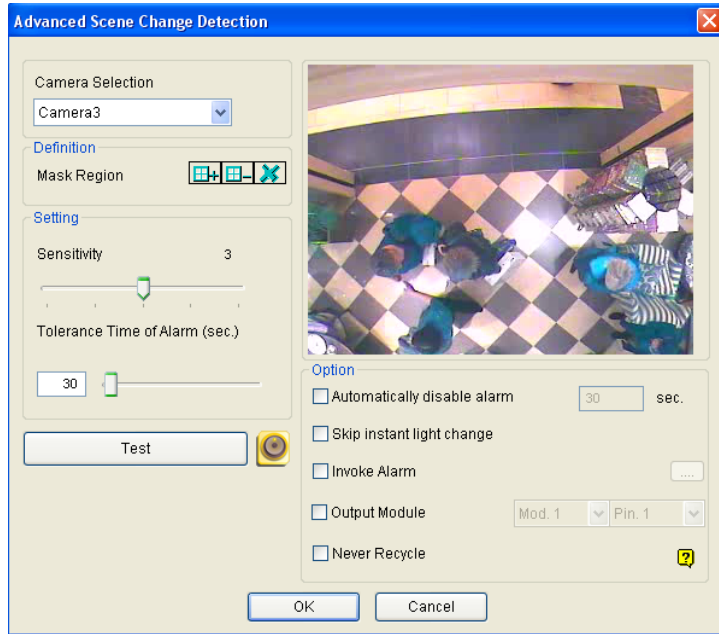

Figure 3-46

3. Select a camera from the Camera Selection drop-down list, and configure these settings:
 - **Mask Region:** If necessary, mask off the area on the camera view where any scene change will be ignored.
 - **Sensitivity:** Adjusts detection sensitivity. The higher the value, the more sensitive the system is for changes in the camera view.
 - **Tolerance Time of Alarm:** Sets the duration of scene change before an alarm condition is activated. Move the slider or type a value (in second) in the blank.
 - **Automatically Disable Alarm:** Stops all types of triggered alerts, including sound alarm, flashing boxes and output module after the specified duration. Disabling the alerts will not disable alert settings and the detection in progress.
 - **Skip Instant Light Change:** Ignores sudden illumination changes to minimize false alarms. For example, light switches can cause illumination changes suddenly. With the option selected, the system will ignore significant illumination changes without triggering the alarm and continue monitoring. See the **Note** below for possible risk.
 - **Invoke Alarm:** Enables the computer alarm when the scene change is detected. Click the [...] button next to the option to assign a .wav sound file.
 - **Output Module:** Activates the output device when the scene change is detected. Select this option and use the drop-down list to assign an installed output module and a pin number.
 - **Never Recycle:** Prevents the system from recycling the event files of scene change when the recycle threshold is reached.

4. You can click **Test** to test your settings. If the scene change cannot be detected, increase **Sensitivity** value to increase system sensitivity to changes in the camera view.
5. Click **OK** to apply the settings.
6. Start monitoring to run the application.

When a scene change is detected in the camera view for the specified time, its location will be highlighted in live video, the selected alarm or output will be activated, and the event will be recorded as **Advanced Scene Change** in System Log for later retrieval.

Note:

1. For the **Skip Instant Light Change** option:
 - When the option is selected, you may be subject to the risk that the system will not generate an alert whenever the lens of the camera is covered by malice.
 - This option is not recommended for infrared cameras.
 2. To create schedules for Advanced Scene Change, see *Creating Schedules*, Chapter 1.
-



To manually stop all triggered alerts, click the **Tools** button  on the triggered channel, select **Reset Alert** and select **Advanced Scene Change Detection**.

- **Reset Alert:** Disables and resets the triggered alert. After the alert is reset, if the scene change remains over the specified tolerance time, the system will still detect it as a scene change and keep generating alert.

3.15 Advanced Unattended Object Detection

The Advanced Unattended Object Detection can generate an alert when any unattended object stays within the camera view. This function can be applied to both the indoor and outdoor environments.

Note: Up to 16 cameras can be configured for this application.

1. Click **Home**  > **Toolbar**  > **Configure**  > **Video process**. The Setup dialog box appears.
2. From the Video Analysis drop-down list, select **Advanced Unattended Object Detection**, select the desired cameras, and click **Setting**. This dialog box appears.

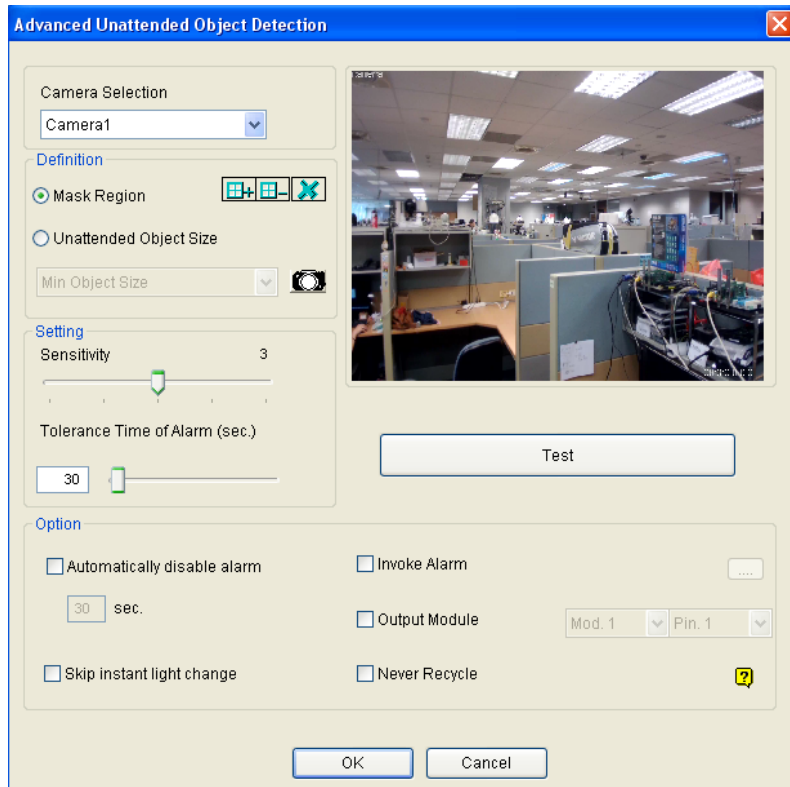

Figure 3-47

3. Select a camera from the Camera Selection drop-down list.
4. If necessary, use the **Mask Region** function to mask off the area on the camera view where motion will be ignored.
5. Select **Unattended Object Size**, and click the Camera icon to pause live images.
6. Outline **Min Object Size** on the camera view, and select **Max Object Size** from the drop-down list and outline the maximum object size on the camera view.
7. To adjust the detection sensitivity, move the **Sensitivity** slider. The higher the value, the more sensitive the system is for changes in the camera view.
8. To adjust the minimum time required for the alarm to be activated, adjust the **Tolerance Time of Alarm** slider or specify a value in the blank.
9. Optionally configure these settings:
 - **Automatically Disable Alarm:** Stops all types of triggered alerts, including computer alarm, flashing boxes and output module after the specified duration. Disabling the alerts will not disable alert settings and the detection in progress.

- **Skip Instant Light Change:** Ignores sudden illumination changes and avoids false alarms. For example, light switches can cause illumination changes suddenly. With the option selected, the system will ignore significant illumination changes without triggering the alarm and continue monitoring. See the **Note** in *Crowd Detection* earlier in this chapter for possible risk.
 - **Invoke Alarm:** Enables the computer alarm when an unattended object is detected. Click the [...] button next to the option to assign a .wav sound file.
 - **Output Module:** Enables the output device when an unattended object is detected. Select this option and use the drop-down list to assign an installed output module and a pin number.
 - **Never Recycle:** With the option selected, the event files of unattended object detection will not be recycled when the recycle threshold is reached.
10. You can click **Test** to test your settings. When an object is left unattended in the camera view, a flashing box will appear on its location for warning. If the unattended object cannot be detected, increase **Sensitivity** value to increase system sensitivity to changes in the camera view.
 11. Click **OK** to apply the settings
 12. Start monitoring to run the application. The detected crowd is indicated on the live view with blinking red and green boxes.

When any unattended object is detected in the camera view for the specified time, its location will be highlighted on live view, the selected alarm or output will be activated, and the event will be recorded as **Advanced Unattended Object Detection** in System Log for later retrieval.

To manually stop all triggered alerts, click the **Tools** button  on the triggered channel, select **Reset Alert** and select **Advanced Unattended Object Detection**.



- **Reset Alert:** Disables and resets the triggered alert. After the alert is reset if the object remains unattended over the specified tolerance time, the system will still detect it as an unattended object and keep generating alert.

Note: Optionally create a schedule for Advanced Unattended Object Detection to be enabled only at the time periods specified. For details, see *Creating Schedules* in Chapter 1.

3.16 Advanced Missing Object Detection

The Advanced Missing Object Detection can generate an alert when any object disappears from the camera view. This function can be applied to both indoor and outdoor environments.

Note: Up to 16 cameras can be configured for this application.

1. Click **Home**  > **Toolbar**  > **Configure**  > **Video process**. The Setup dialog box appears.
2. From the Video Analysis drop-down list, select **Advanced Missing Object Detection**, select the desired cameras, and then click **Setting**. This dialog box appears.

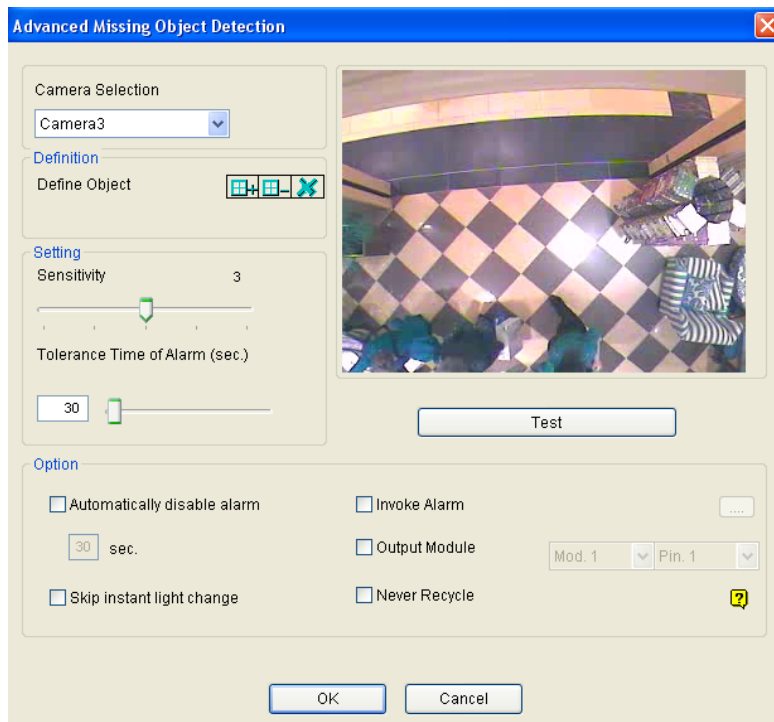





Figure 3-48

3. Select a camera from the Camera Selection drop-down list.
4. Click the  button to outline the regions on the objects you want to detect. To cancel a previously drawn area, click the  button and outline the area. To remove all previously drawn areas, click the  button.
5. To adjust detection sensitivity, move the **Sensitivity** slider. The higher the value, the more sensitive the system is for changes in the camera view.
6. To change the minimum duration required for the alarm to be activated, move the **Tolerance Time of Alarm** slider or specify a value (in seconds) in the blank.

7. In the Options section, configure these settings:
 - **Automatically Disable Alarm:** Stops all types of triggered alerts, including sound alarm, flashing boxes and output module after the specified duration. Disabling the alerts will not disable alert settings and the detection in progress.
 - **Skip Instant Light Change:** Ignores sudden illumination changes to avoid false alarms. For example, light switches can cause illumination changes suddenly. With the option selected, the system will ignore significant illumination changes and continue monitoring. See the **Note** in *Crowd Detection* earlier in this chapter.
 - **Invoke Alarm:** Enables the computer alarm when an object is detected to be missing. Click the [...] button next to the option to assign a .wav sound file.
 - **Output Module:** Enables the output device when an object is detected to be missing. Select this option and use the drop-down list to assign an installed output module and a pin number.
 - **Never Recycle:** With the option selected, the event files of missing object detection will not be recycled when the recycle threshold is reached.
8. You can click **Test** to test your settings. When the defined object is missing, a flashing box will appear on its location for warning. If the missing object cannot be detected, increase **Sensitivity** value to increase system sensitivity to changes in the camera view.
9. Click **OK** to apply the settings.
10. Start monitoring to run the application. The detected crowd is indicated on the live view with blinking red and green boxes.

When any object, which you have outlined the regions for, disappears from the camera view for the specified time, its location will be highlighted in live view, the selected alarm or output will be activated, and the event will be recorded as **Advanced Missing Object Detection** in System Log for later retrieval.



To manually stop all triggered alerts, click the **Tools** button  on the triggered channel, select **Reset Alert** and select **Advanced Missing Object Detection**.

- **Reset Alert:** Disables and resets the triggered alert. After the alert is reset if the object remains missing over the specified tolerance time, the system will still detect it as a missing object and keep generating alert.

Note: Optionally create a schedule for Advanced Missing Object Detection to be enabled only at the time periods specified. For details, see *Creating Schedules* in Chapter 1.

3.17 Text Overlay

You can align camera name, time stamp and triggered input name to different positions for each channel.

1. Click **Home**  > **Toolbar**  > **Configure**  > **Video process**. The Setup dialog box appears.
2. From the Video Analysis drop-down list, select **Text Overlay Setting**, select the desired cameras, and click **Setting**. This dialog box appears.

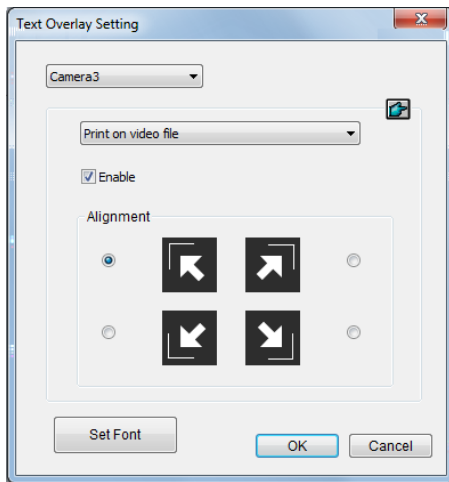





Figure 3-49

3. Select a camera from the drop-down list.
4. In the Options section, configure these settings:
 - **Print on video file:** Displays camera ID, location name, date and time on recorded videos.
 - **Print on screen (Only for IO alarm):** Displays the name of triggered input device on the camera screen. For this function to work, it is required to map a camera to an input device, see *Other I/O Application Functions* in Chapter 6.
 - **Embed Counting Results into Recorded Video:** Displays counter results to recorded videos. For details on establishing a counter alarm, see *Object Counting* later in this chapter.
 - **Print ASManager Text on Screen:** Displays GV-ASManager data such as the license plate number on the live view and recorded videos. For this function work, it is required to enable the text overlay setting in GV-ASManager. See *5.6 Using Text Overlay*, Chapter 5, in [GV-ASManager User's Manual](#).

Note: Text overlay is not supported when standard format codec is enabled. To change this setting, select **Home**  > **Toolbar**  > **Configure**  > **Camera Install** > **Settings**  of the camera > **General Setting** and locate the Recording codec format field.

- **Alignment:** Select how you want the camera information to be aligned on a camera screen.
- **Set Font:** Click to configure the font, font size, font style and related settings.

3.18 Fisheye View

A fisheye camera allows you to cover all angles of a location with just one fisheye camera. Using different fisheye view modes, the distorted hemispherical image produced by the fisheye camera can be converted to a conventional rectilinear projection.

Note: To use the fisheye dewarping function, the graphic card supporting DirectX 10.1 or above is required.

You can choose among four view modes and adjust the PTZ views to different angles.



Quad view: 4 PTZ views



360 degree: 2 PTZ view & 1 360° view

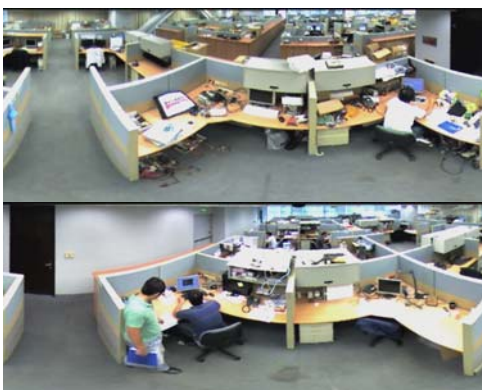

Dual 180 degree: 2 180° views

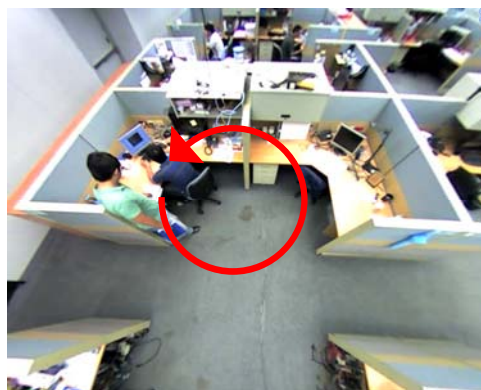

Single view: 1 PTZ view

Figure 3-50

3.18.1 Setting up a GV-Fisheye Camera

1. Make sure you have connected the fisheye camera to the GV-VMS. The camera should appear in the Content List.
2. From the Content List, drag the fisheye camera (circular source image) or one of the dewarpped fisheye images (e.g. Quad View) to the live view grid.
3. To change the fisheye settings, right-click the fisheye camera from the Content List and select **Fisheye Settings**. The Fisheye Setting dialog box appears.

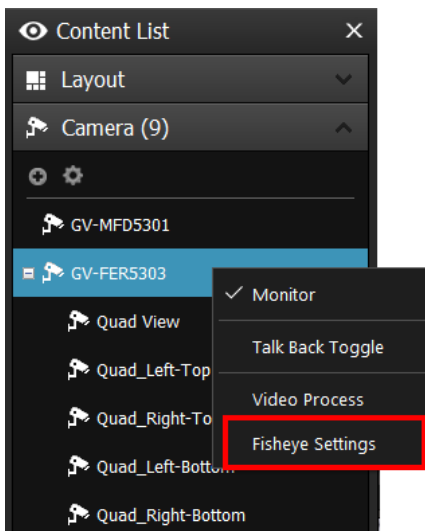

Figure 3-51

4. Right-click on the Fisheye Setting dialog box, point to **Fisheye Option** to access the following settings:
 - **Camera Modes:** You can choose among four view modes.
 - ⊙ **Geo Fisheye: Quad view:** Composed of four PTZ views.
 - ⊙ **Geo Fisheye: 360 degree:** Composed of two PTZ views and one 360° panoramic view.
 - ⊙ **Geo Fisheye: Dual 180 degree:** Composed of two 180° views.
 - ⊙ **Geo Fisheye: Single view:** Composed of one PTZ view. This view mode supports the advanced Picture-in-Picture (PIP) function, which allows you to have a close-up dewarpped image within the surveillance area without missing the entire view.
 - **Camera Position:** Select **Ceiling**, **Wall** or **Ground** according to where the camera is mounted.
 - **Adjust Auto Pan Speed At Top-Left Channel:** Select low, medium, or high speed to enable Auto Pan for one PTZ view at the rotation speed of your choice. This option applies to **Quad view**, **360 degree** and **Single view**.

- **Zoom:** Select **Zoom In** or **Zoom Out** and then click on the image.
- **Show Source Video At Top-Right Channel:** You can display the circular source image in the top-right quadrant when **Quad view** is selected.
- **360 Object Tracking:** This option is only available for **360 degree** view. Select **Tracking** for moving object to be tracked in the top-right PTZ view and highlighted in the 360 degree view at the bottom. For details, see *Object Tracking* later in this chapter.
 - ⊙ **Disable automatic zoom adjustment during 360 Object Tracking:** Enabled by default. When disabled, the zoom ratio will be kept at constant as configured.
- **Disable PIP:** Disables the PIP function for the Single View mode.
- **Guard Tour Setting:** Guard tour is a PTZ tour for monitoring important spots on the live view. This option is only available under the **Single View** mode. For details, see *Virtual PTZ Tour* later in this chapter.
- **Settings:**

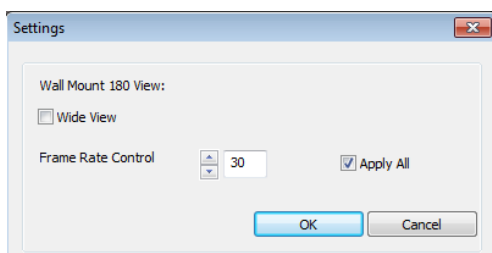

Figure 3-52

- ⊙ **Wide View:** Increases the height of the 180 degree view when camera position is set to wall mount.

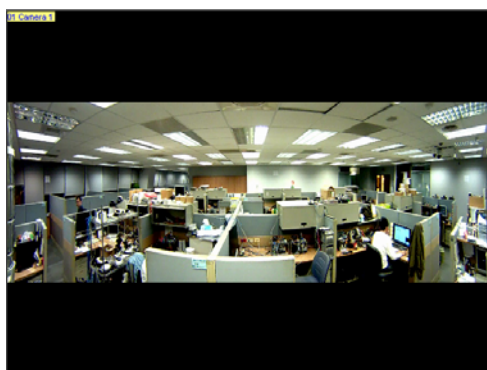

Figure 3-53: Wide View Disabled







Figure 3-54: Wide View Enabled

- ⊙ **Frame Rate Control:** Limits the frame rate of the fisheye live view to the number specified here. Select **Apply All** to apply the frame rate control to other fisheye views.

5. You can drag and drop PTZ view or 180 degree view to adjust the viewing angle.

3.18.2 Setting up a Third-Party Fisheye Camera

You can also enable dewarping for 3rd party fisheye cameras and access fisheye related functions.

1. Make sure you have connected the fisheye camera to the GV-VMS. The camera should appear in the Content List.
2. Select the camera lens type to dewarp the image.
 - A. Click **Home**  > **Toolbar**  > **Configure**  > **Camera Install**. The IP Device Setup dialog box appears. Then click the Settings button  of the desired camera.
 - B. For the camera installed with an ImmerVision IMV1 Panorama Lens, select **IMV1 Panomorph** using the Camera Lens drop-down list.
 - C. For other third-party fisheye cameras, select **Fisheye** using the Camera Lens drop-down list.

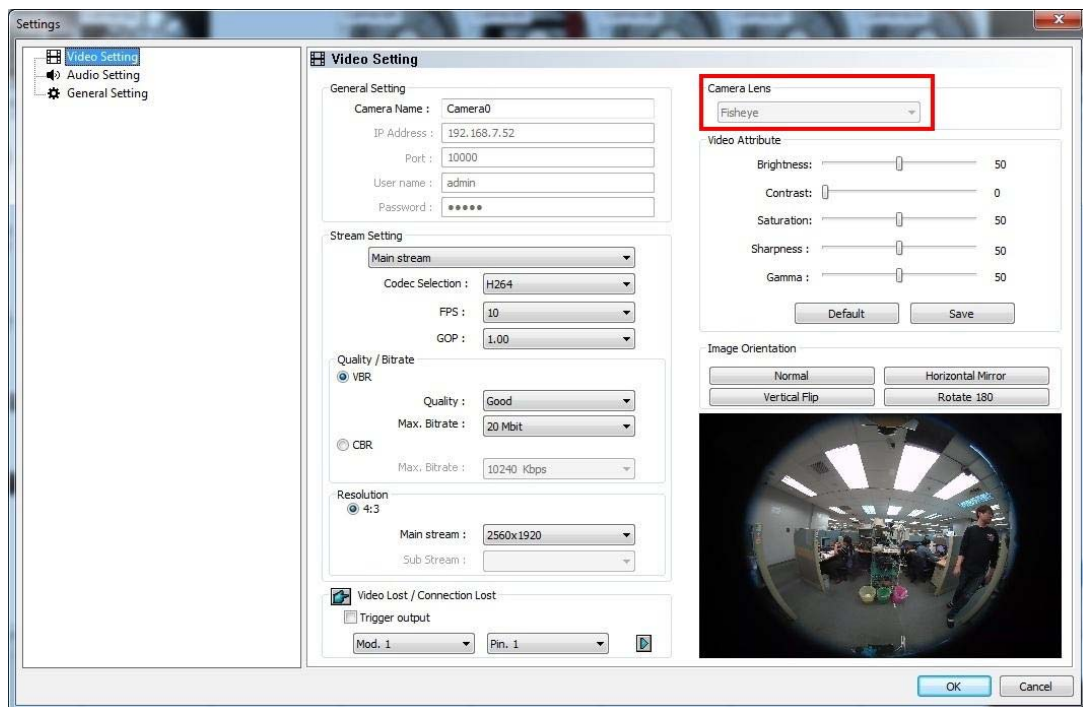

Figure 3-55

3. From the Content List, drag the fisheye camera (circular source image) or one of the dewarped fisheye images (e.g. Quad View) to the live view grid.
4. To access fisheye related functions, follow Steps 2 to 4, *Setting Up a GV-Fisheye Camera* later in this chapter.

- To adjust the image alignment for optimal results, follow Steps 2 and 3, *Setting Up a GV-Fisheye Camera* later in this chapter and select **Image Alignment**. In the dialog box, align the dotted circle with the outer edge of the camera image, and then align it with the inner edge of the image frame.

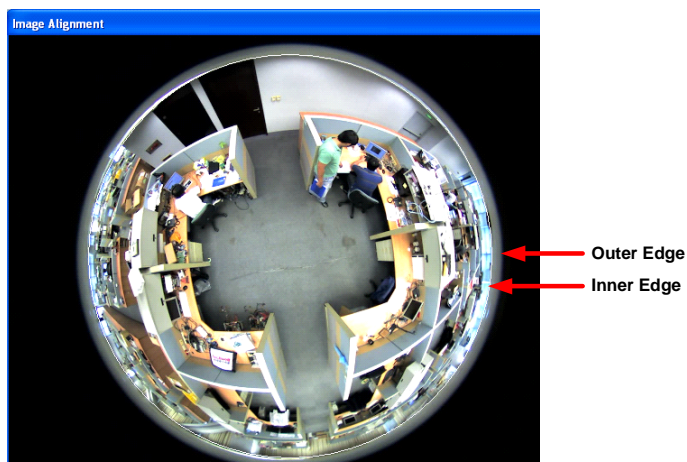





Figure 3-56

Note:

- For GV-Fisheye Cameras, the image alignment function is only available on its Web interface.
 - Regardless of the view mode selected here, the hemispherical fisheye source image will be recorded. When playing back fisheye events in ViewLog, GV-VMS can convert the source image to different view modes according to your preference. To play back the events in fisheye view mode, select **ViewLog**  > **Toolbar**  > **Content List**  and select a dewarped view of the camera.
-

3.18.3 Object Tracking

You can now set up object tracking in fisheye live view to track moving object. The function is only available when the fisheye camera mode is set to be **Geo Fisheye: 360 degree**. When motion is detected in the fisheye, the top-right channel will start tracking the moving object and in the 360 degree view at the bottom, the moving object will be highlighted.

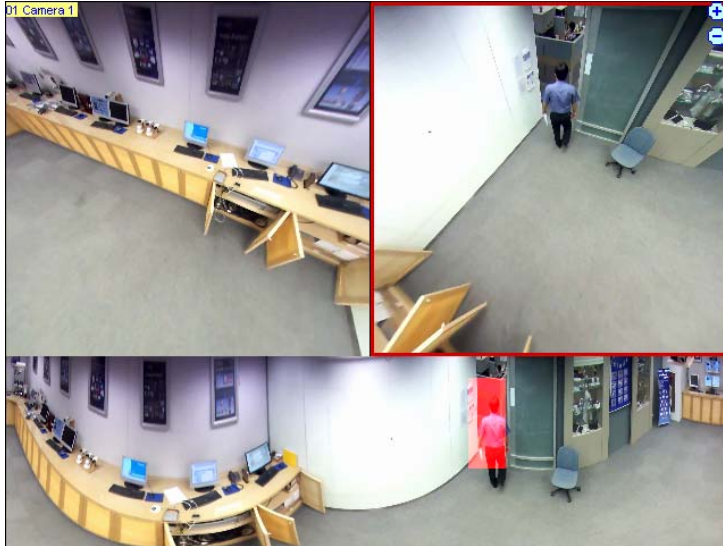

Figure 3-57

1. Make sure the fisheye view mode is set to the 360 degree mode. For details, see Step 4 in *Setting Up a GV-Fisheye Camera*, earlier in this chapter.
2. Right-click the fisheye camera from the Content List and select **Fisheye Settings**. The FE Setting dialog box appears.
3. Right-click on the FE Setting dialog box, point to **Fisheye Option**, select **360 Object Tracking** and then select **Advanced Settings**. This dialog box appears.

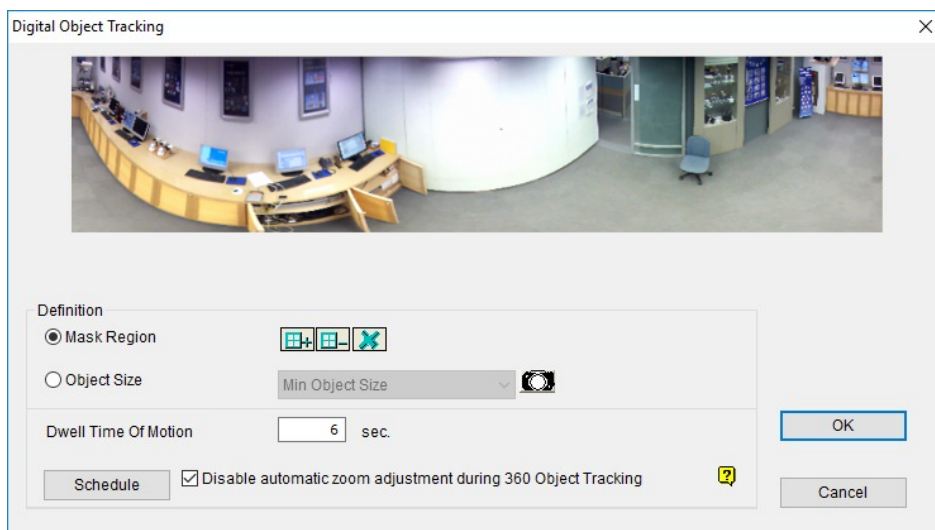



Figure 3-58

4. Use the options below to customize object tracking.
 - **Mask Region:** Use the mouse to outline a mask region where motion will be ignored.
 - **Object Size:** Click the  button to pause the live view and then use the mouse to outline the maximum and minimum size of the targeted object.
 - **Dwell Time of Motion:** After a targeted object stops moving, the highlighted region and the top-right channel will remain fixed on the area for the number of seconds specified. Any new motion detected during the dwell time will be ignored to prevent the camera view from frequently jumping from one area to another.
 - **Schedule:** Click **Schedule** to set up the times for object tracking. See the next step for details.
5. Set up a schedule.

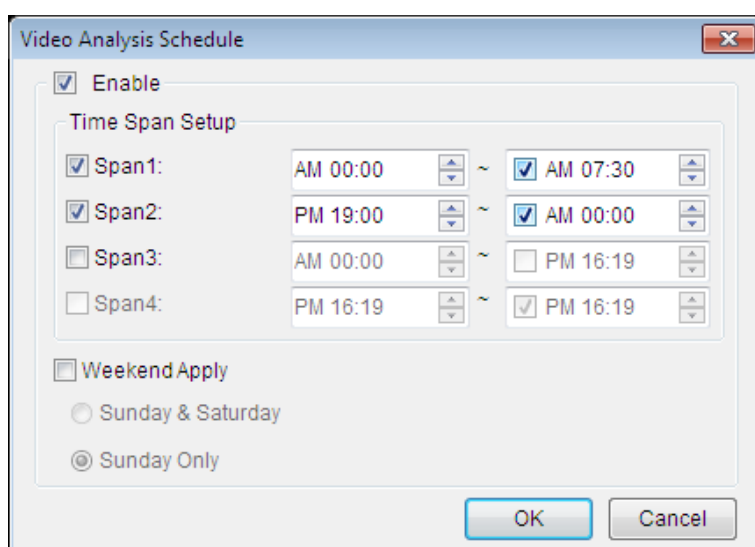

Figure 3-59

- A. Select **Enable**.
 - B. Select **Span 1** and specify a time period. The period that you specify is effective from Mondays to Fridays.
 - C. Optionally select more span and specify the time period.
 - D. To apply the week day time periods to weekends, select **Weekend Apply** and select **Sunday & Saturday** or **Sunday Only** according to your needs.
 - E. Click **OK** to save the settings.
6. To start object tracking, right-click the fisheye view, select **Fisheye Option**, select **360 Object Tracking** and select **Tracking**.

3.18.4 Virtual PTZ Tour

Set up a virtual PTZ tour to monitor important spots of your surveillance site. Before you start, make sure your GV-Fisheye Camera is set to the **Single View** mode. For details on the view mode, see *Cameras Modes*, in *Setting Up a GV-Fisheye Camera* section, earlier in this chapter.

1. Make sure your live view is set to the Single View mode. For details, see Step 4, *Setting Up a GV-Fisheye Camera* earlier in this chapter.
2. Move your live view to a desired starting place for the PTZ tour by clicking on the inserted window on the bottom right of the live view.
3. Right-click the camera live view, select **Fisheye Option** and then select **Guard Tour Setting**. This dialog box appears.

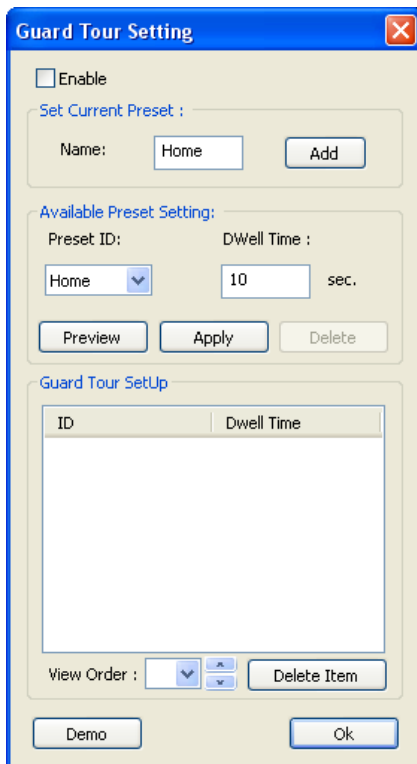

Figure 3-60

4. Type a name for the current live view and click **Add**. This live view point (preset point) automatically appears under Preset ID.

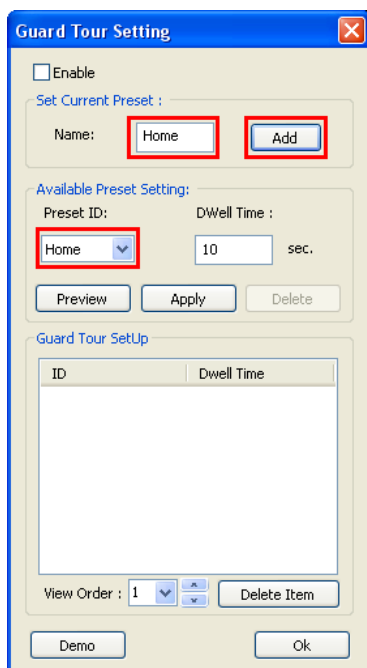

Figure 3-61

5. Specify the duration for the live view to stay on this preset point (dwell time). The default setting is **10** seconds.
6. Optionally click **Preview** to see a preview of the preset point.
7. Click **Apply**. This preset point is added to Guard Tour Setup.

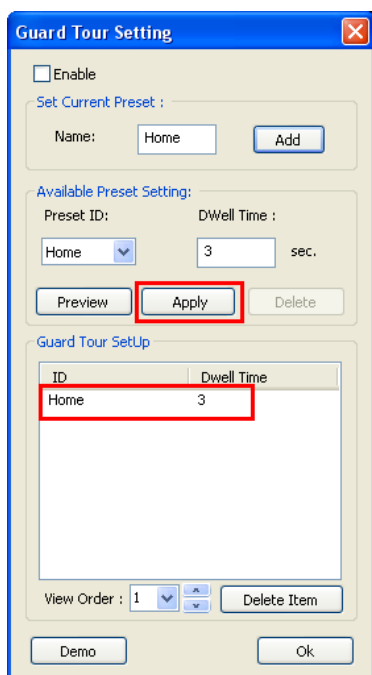

Figure 3-62

8. To add more preset points, follow Steps 1 to 6. For example, three preset points Home, Gate and Desk are established in this setup.

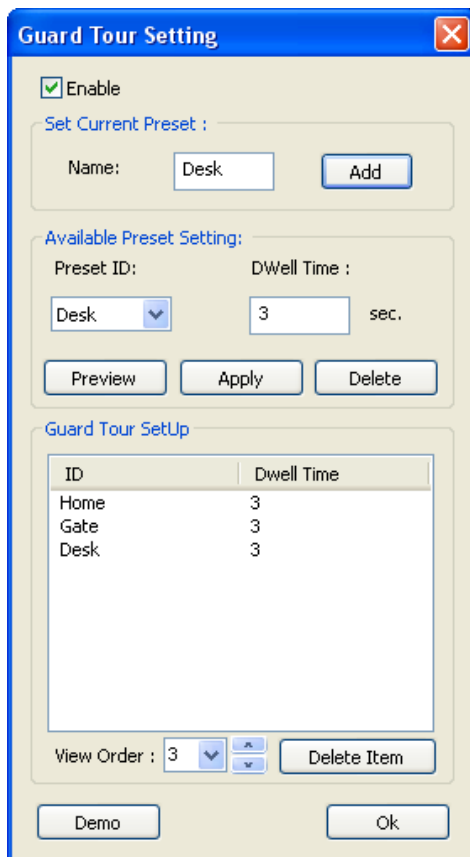

Figure 3-63

9. To change the order of the preset points, select a preset point from the ID column and select a number from the drop-down list to move this preset point up or down the list.
10. Optionally click **Demo** to watch a preview of the PTZ tour.
11. Select **Enable** to start the PTZ tour. To stop the PTZ tour, disable this function on the Guard Tour Setting.



3.19 Video Analysis by Camera

You can now choose to process video analysis on the camera instead of on GV-VMS software.

Currently only GV-BX2600 supports full video analysis functions running on the camera, including Motion Detection, Intruder, People Count, Missing Object, Unattended Object, Loitering, and Tampering Alarm functions. For all other camera models, only Motion Detection and GV-3D People Counter are supported to process on the camera.

Note: You may only choose either the camera or GV-VMS software to process video analysis.

To access the feature, follow the steps:

1. Click **Home**  > **Toolbar**  > **Configure**  > **Video Process**.
2. In the Setup dialog box, select **IPCVA**, select the camera(s), and select **Setting**.
3. Select which video analysis to process on the camera.

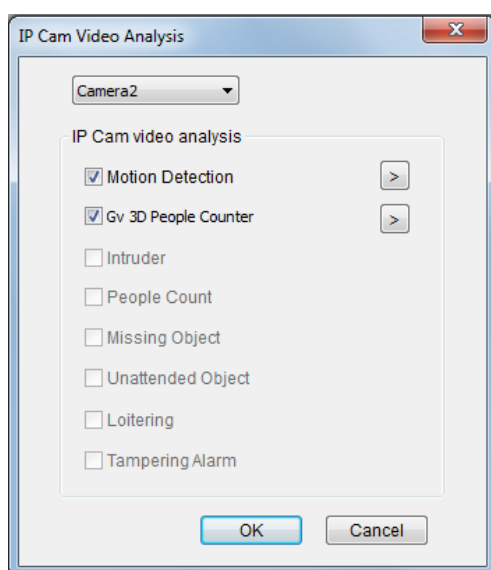



Figure 3-64

4. For motion detection option, click on the **arrow**  button to activate the following functions:
 - A. Adjust the level of sensitivity by moving the slider to the desired value, with 1 being the least sensitive and 10 being the most sensitive.

- B. Select the area of motion detection by drawing an area on the live view. You may draw 8 areas in maximum.

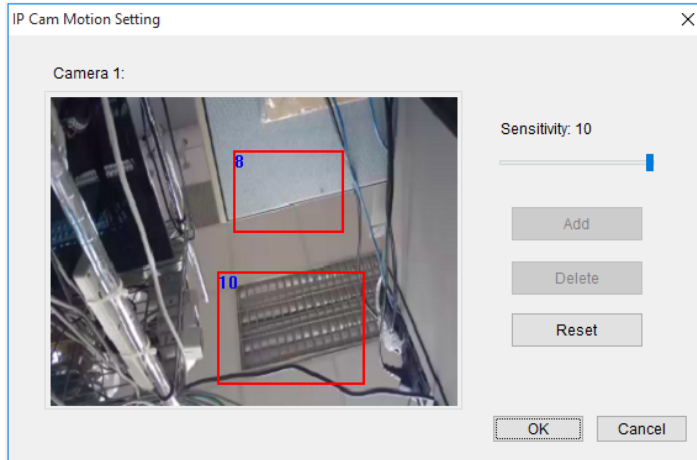

Figure 3-65

All video analysis events detected on the camera will be recorded in GV-VMS System Log. For example, if you set up the People Count function on GV-BX2600, the following analysis results appear:

Monitor Table									
Monitor	System	Login	Counter	Merge	Backup	Delete	Notification	I/O	Playback
Start Time	End Time	Device	In	Out					
6/15/2015 10:50:12	6/15/2015 15:40:01	Camera1	155	271					
6/15/2015 20:37:22	6/15/2015 20:38:34	Camera1	23	12					
6/16/2015 16:10:34	6/16/2015 16:16:03	Camera1	67	0					

Figure 3-66

5. For the function of GV-3D People Counter, select right beside GV-3D People Counter.
- A. Type the IP address, ID and Password of GV-3D People Counter. Select **Test** to see if GV-3D People Counter is properly connected. Select **OK** to establish connection.

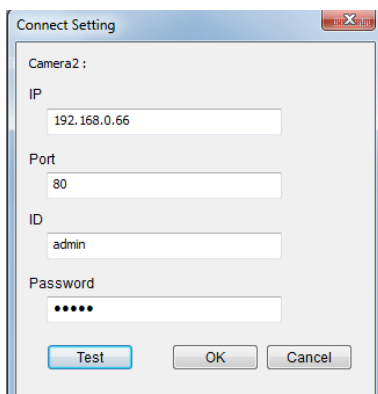

Figure 3-67

- B. On the live view of the camera, select **Tools**  and **Monitor**. You will see the number of people going pass the detection area of the camera.





Figure 3-68

3.20 Heat Map

With the Heat Map feature, you can see the level of motion intensity in a region, which is represented by different shades of colors. The visualized traffic data will inform you where people go through and stay often. This feature is available in both live view and video playback.

Note: **Stabilization** and **Defogging** are not supported when **Heat Map** is enabled.

3.20.1 Enabling Heat Map

1. Click **Home**  > **Toolbar**  > **Configure**  > **Video process**. The Setup dialog box appears.
2. From the Video Analysis drop-down list, select **Heat Map**, select the desired cameras, and click **Setting**. The Heat Map Settings dialog box appears.
3. Select a camera from the Camera drop-down list.

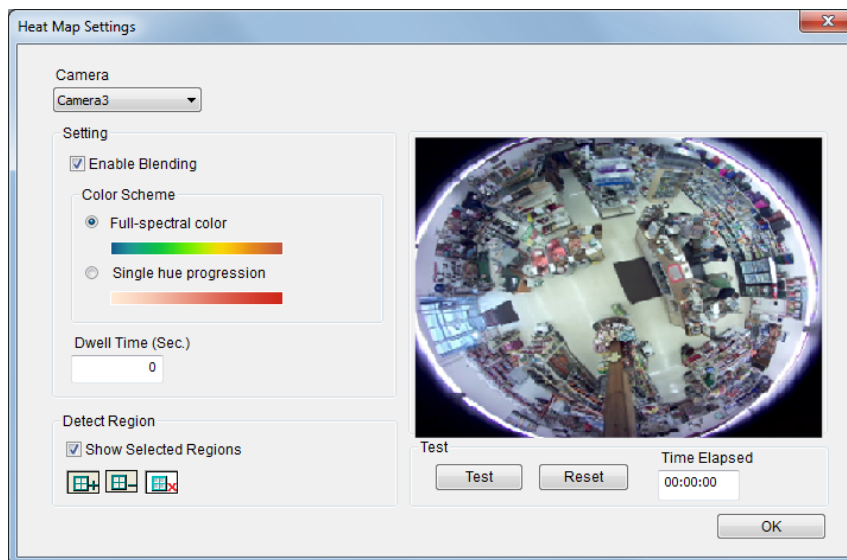





Figure 3-69

4. If you want to enable heat map on the live view, select **Enable Blending**.

Note: If **Enable Blending** is unselected, heat map will not be displayed on live view, but heat map analysis can still be accessed through video playback.

5. To specify a certain area for Heat Map analysis, click the plus sign , and draw an area on the live view. To exclude a selected area from analysis, click the minus sign , draw and crop the area. To clear the whole selected area, click the X sign .

Note: To draw a shape, click on the live view and draw a line, move the cursor to a different place and click again. To complete the drawing, connect the end of two lines.

6. You can select from two color modes:

- **Full-spectral color:** The redder the hue, the higher the motion intensity; the bluer the hue, the less motion intensity.
- **Single hue progression:** The darker the hue, the higher the motion intensity; the lighter the hue, the less motion intensity.



Figure 3-70: Full-spectral color mode

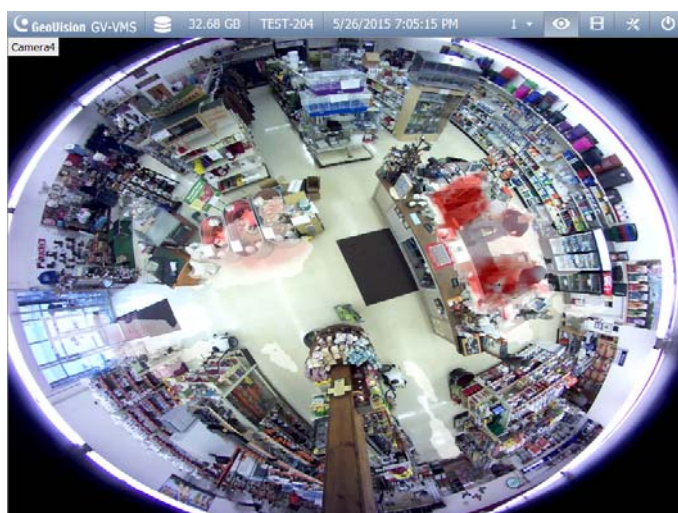



Figure 3-71: Single hue progression mode

7. Type the number of seconds under **Dwell Sec** to determine the number of seconds a motion remains at an area before the Heat Map analysis starts.
8. To preview the effects, click the **Test** button. To clear all the preview results, click the **Reset** button. **Time Elapsed** shows how much time has passed since your testing has started.
9. Click **OK** and start monitoring.
10. To clear the heat map results on the live view, click the **Tools** button  on the channel window with heat map analysis, click **Reset Alert**, and click **Heat Map**.

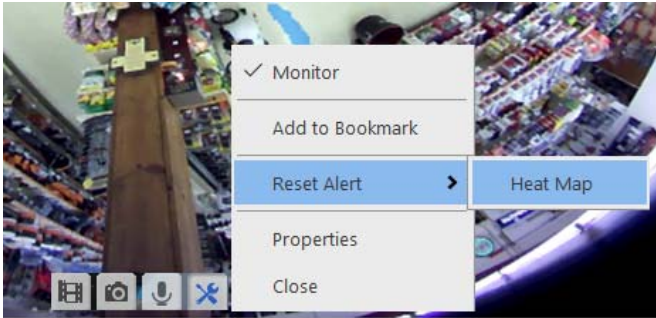

Figure 3-72

3.20.2 Accessing the Heat Map in Recordings

You can freely define a period of time and apply the heat map analysis in recordings.

1. On the ViewLog player, right-click the desired image and select **Heat Map**. This dialogue box appears.

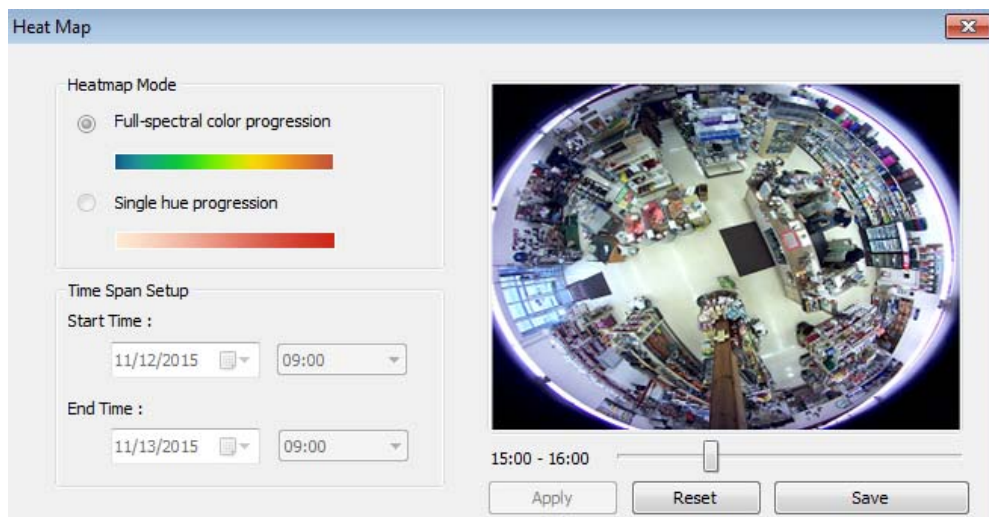

Figure 3-73



2. Select the color mode for the Heat Map analysis under **Color Scheme**.

3. Select the Start Time and End Time under **Time Span Setup**. You may move the slider under the image to see the heat map analysis of each hour.
4. Click **Apply** to see the preview. To clear all the preview results, click the **Reset** button.
5. Click **Save** to save an image of the Heat Map analysis.

Note: The time interval for the Time Span Setup must be less than 24 hours.

3.21 Event Alert through E-mail Notification

You can choose to be notified of specific types of alert events through e-mail notification. To fully activate the function, see 1.6.4 *Setting Up Email Notification* to set up e-mail notification and be sure that the settings of each type of events are configured in advance.

1. Click **Home**  > **Toolbar**  > **Configure**  > **Video Process**.
2. Click the arrow button  next to Send Event Alerts. This dialog box appears.

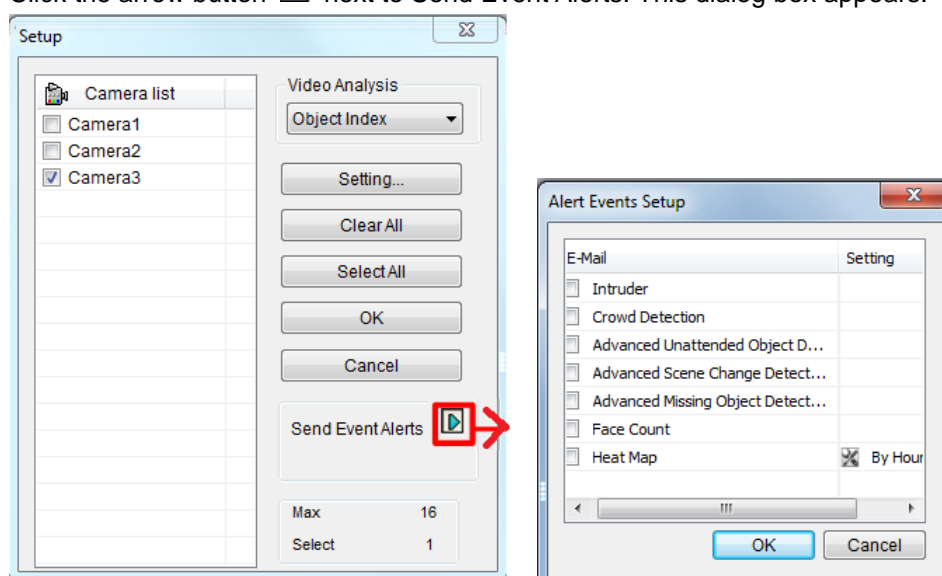

Figure 3-74

3. Select types of events for e-mail notification.
4. Click **OK** to apply the settings.



3.22 PTZ Object Tracking

By combining a PTZ and a stationary camera, you can automatically track and zoom on a single moving object on live view. You can also use only one PTZ camera for object tracking.

3.22.1 Dual-Camera Tracking

To automatically track an object, you need one PTZ camera set for tracking and one stationary camera set for a fixed view. Install the PTZ camera and the stationary camera in close proximity of each other so the focus and the camera view of both resemble each other.

Note: The Dual-Camera Tracking function is only supported by GV-PTZ010D, GV-SD220 Series, GV-SD2722-IR / SD2723-IR / SD2733-IR / SD2300 / SD2301 / SD2411.

1. Click **Home**  > **Toolbar**  > **Configure**  > **Object Tracking Setup**. The Object Tracking Config dialog box appears.
2. Select a **PTZ Camera** from the left drop-down list and a **Fixed Camera** from the right drop-down list.
3. Select **Enable Tracking** and start the settings.

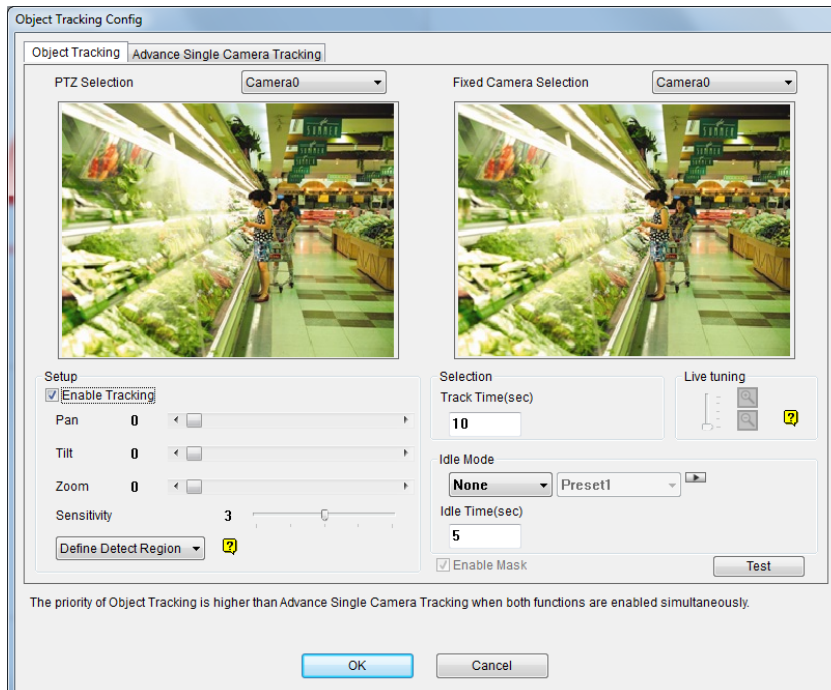

Figure 3-75

4. Use the **Pan, Tilt** and **Zoom** sliders to adjust the current PTZ camera view.
5. Specify **Tracking Duration** in seconds for every tracking movement.
6. Specify **Idle Mode** and **Idle Time**. When the PTZ camera remains stationary for a specified time, the camera can automatically move to a Home position, a Preset Point, or start an Auto setting.
7. Select **Define Detection Region** from the drop-down menu. Outline an area on the right (Fixed Camera) image. You are prompted to confirm **Detect Region**.

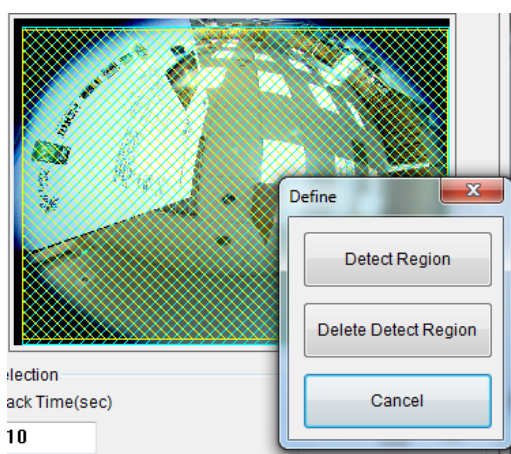

Figure 3-76

8. Select **Define Object Size** from the drop-down menu. Outline the max and min object sizes for tracking targets separately on the right (Fixed Camera) image. Every time when finishing the outlining, you will be prompted to confirm **Maximum Object Size** or **Minimum Object Size**.

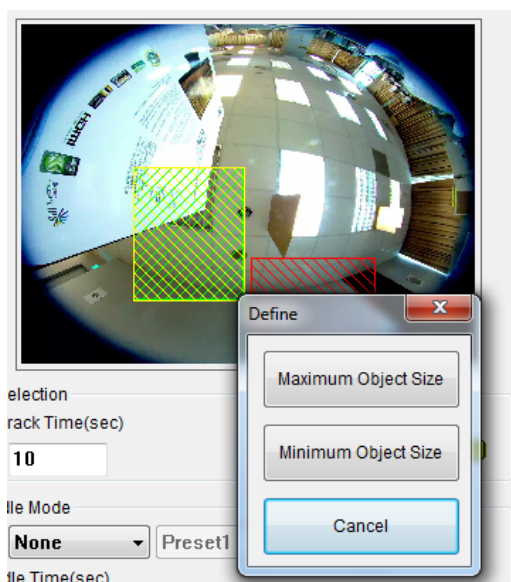



Figure 3-77

9. Click **Test** and move an object through the camera view to see if its movement is tracked or not. There are two major settings you have to observe in the test. 1) Tracking: Observe if the target shown in the defined detection region is being tracked with a highlighted mask, and magnified automatically in the left (PTZ) image. If not, increase the sensitivity degree. 2) Zooming: Observe if the target is magnified in the left (PTZ) image clearly. If not, use the **Live Tuning** buttons to adjust the level of zooming.
10. Click **OK** to apply the settings.
11. To start object tracking, click **Toolbar** , select **Tools**  and select **Object Tracking Start**.

Tip: You can interrupt the PTZ camera tracking and take over the camera control by using PTZ Control Panel, PC's keyboard and GV accessories such as GV-KeyBoard, GV-IR Remote Control, and GV-Joystick. When the controlling device or panel is inactive for over 5 seconds, the PTZ camera will go back for tracking.



Note: When multiple objects are moving at the same time, the camera will track the object with the largest area.

3.22.2 Single Camera Tracking

The Advanced Single Camera Tracking can track a moving object using only one PTZ camera. When an object moves within the view of camera, the PTZ camera will follow its movement. When the object is out of view, the PTZ camera can be set to return to a designated position.

Note:

1. The Single Camera Tracking function is only supported by GV-PTZ010D, GV-SD200, GV-SD220 Series, GV-SD2723-IR / SD2733-IR / SD2300 / SD2301 / SD2411.
 2. For GV-SD2722-IR / SD3732-IR, a similar tracking function can be accessed through the PTZ Control Panel. See *Accessing PTZ Control Panel and Auto Functions*, in Chapter 1.
-

1. Click **Home**  > **Toolbar**  > **Configure**  > **Object Tracking Setup** > **Advanced Single Camera Tracking** tab. This dialog box appears.

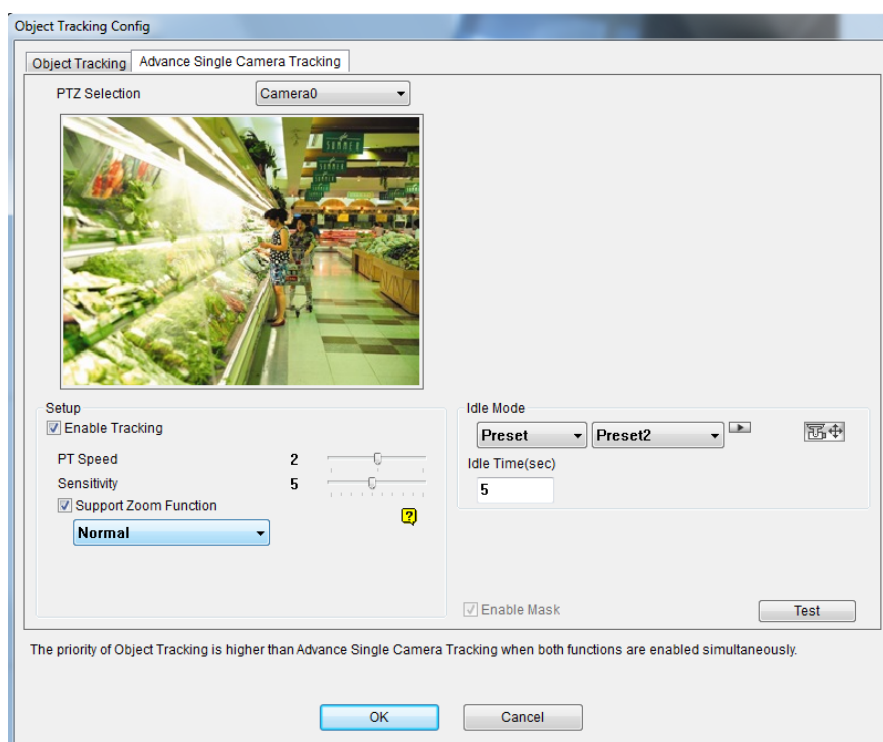



Figure 3-78

2. Select the camera from the **PTZ Selection** drop-down list.
3. Select **Enable Tracking** to start the following settings.
4. Select **Support Zoom Function** to be able to zoom in and out. Select **Normal** and the camera will zoom in once on the moving object. Select **Deep Zooming** and the camera will zoom in three times on the moving object.
5. Click the  button to adjust the direction and zoom level of the camera.
6. To set the camera to return to its home position or a preset position when no motion is detected for a certain time period, specify **Idle Mode** and **Idle Time** in seconds. Click the  button to preview the designated position. Note that your camera will need to support home position and preset position.
7. To outline an area where motion will be ignored, draw an area on the camera view and select **Set Mask** on the dialog box that pops up. To remove the mask, draw an area bigger than the mask, and click **Remove Mask**.
8. Click **Test** and move an object through the camera view to see if its movement is tracked or not. If not, move the **Sensitivity** slider to increase the sensitivity of motion detection. If the tracking speed is not fast enough, move the **PTZ Speed** slider to adjust the speed of PTZ movement. If you have set up a mask, you can select **Enable Mask** to display the masked area during the test.

9. Click **OK** to apply the settings.

10. To start object tracking, click **Toolbar**  > **Tools**  > **Object Tracking Start**.

Tip: You can interrupt the PTZ camera tracking and take over the camera control by using PTZ Control Panel, PC's keyboard and GV accessories such as GV-Keyboard, GV-IR Remote Control, and GV-Joystick. When the controlling device or panel is inactive for over 5 seconds, the PTZ camera will go back for tracking.

Note: When multiple objects are moving at the same time, the camera will track the object with the largest area.

3.23 Panoramic PTZ Object Tracking

With the hybrid GV-Panoramic PTZ Camera, you can track moving object on live view. The fisheye camera allows you to monitor all angles of a location, while the speed dome can instantly point toward an area with just one click on the fisheye live view. In addition to that, you can also set up object tracking in fisheye live view to track moving object. When motion is detected in the fisheye, the speed dome will start tracking the moving object and in the 360 degree view, and the moving object will be highlighted.

Note: This function is only supported by GV-PPTZ7300 / 14021 / 14031.

3.23.1 Accessing the Live View

To access the live view of the GV-Panoramic PTZ Camera, drag both the fisheye camera channel and speed dome channel in the Content List to the live view grid. Click on the fisheye live view, and the camera will turn toward the selected location.

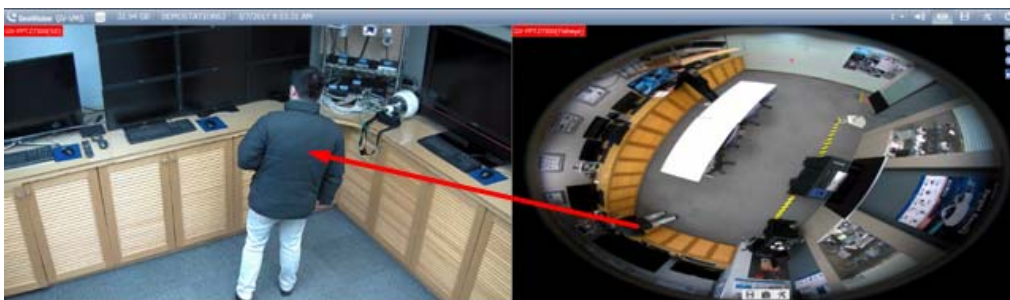



Figure 3-79

3.23.2 Automatic Object Tracking

The PPTZ Automatic Object Tracking function only works in a 3-division live view. Follow the steps to create the 3-division live view and to enable the PPTZ Object Tracking in the 360 View.



Figure 3-80

1. Click **Home**, select **Toolbar**, and select **Content List**.
2. Under **Layout**, click **Add** , and select **Add Layout**.

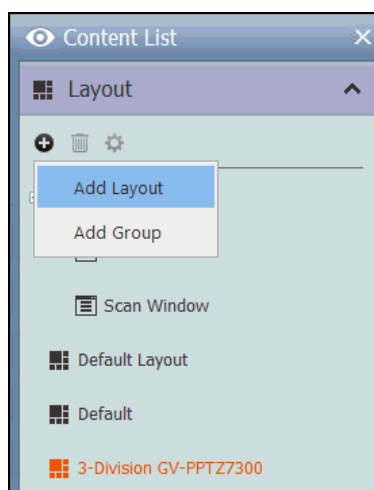

Figure 3-81

3. Type the name of the layout under **Name**, select **Customize**, and click **OK**.

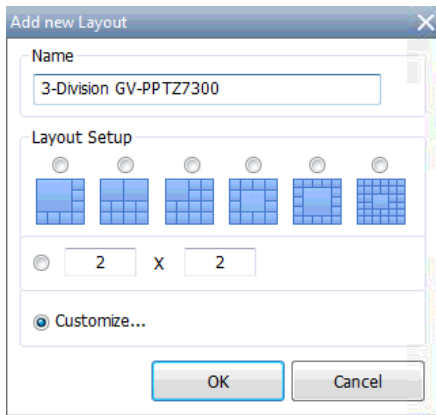



Figure 3-82

4. Click **Reset**  to create a 2 x 2 live view grid, and click **OK**.

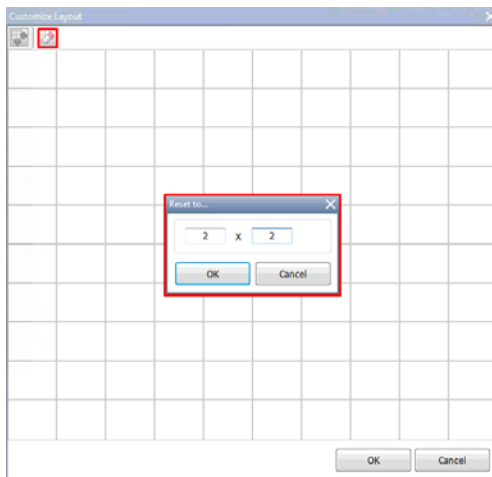

Figure 3-83

5. Select the 2 grids at the bottom, click **Merge** , and click **OK** to merge the grids.

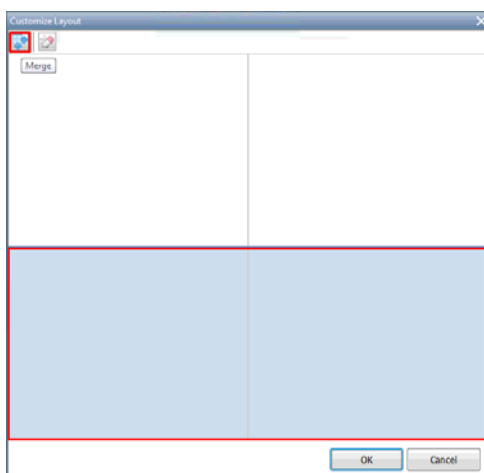

Figure 3-84

- Click **No** to assign the camera channels manually.

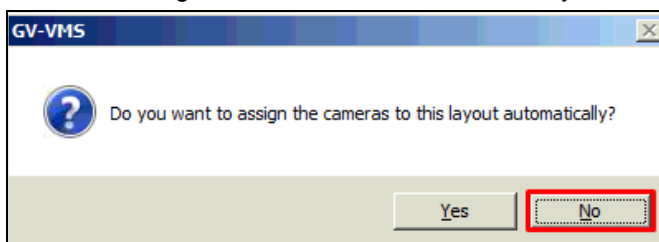

Figure 3-85

- Drag **360 View**, **SD View** and **FE View** to the live view grid.

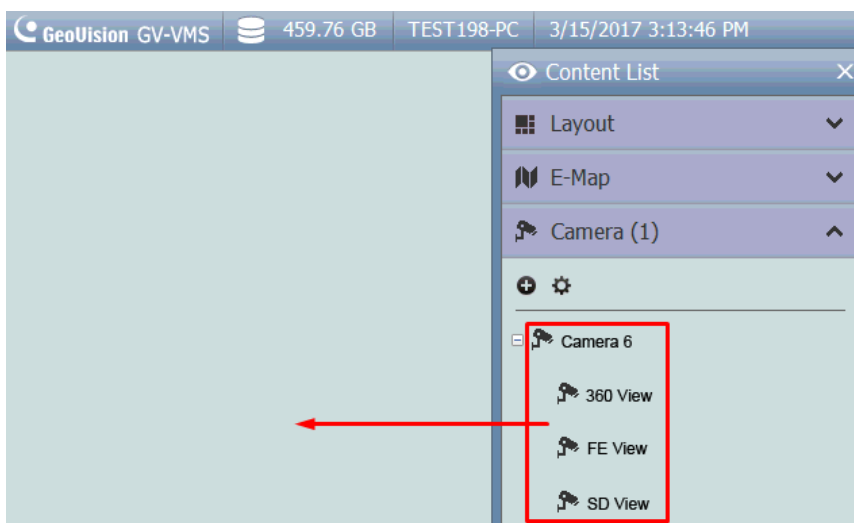

Figure 3-86

After creating the 3-division live view, go through the steps below to enable the object tracking options.

- To track moving objects, click **Home**, select **Toolbar**, and select **Content List**. The Content List appears.
- Right-click the GV-PPTZ7300 and select **PPTZ Setup**. The Fisheye Settings dialog box appears.

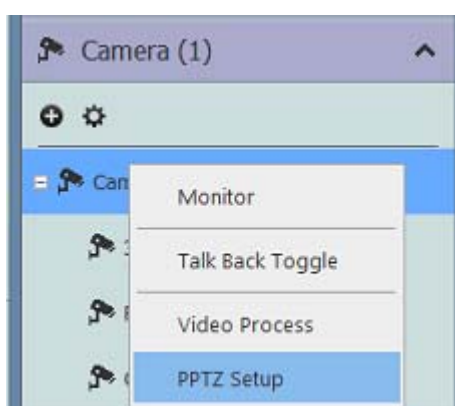

Figure 3-87

- Right-click on the Fisheye Settings dialog box and select **Fisheye Option > Camera Mode > 360 View**.

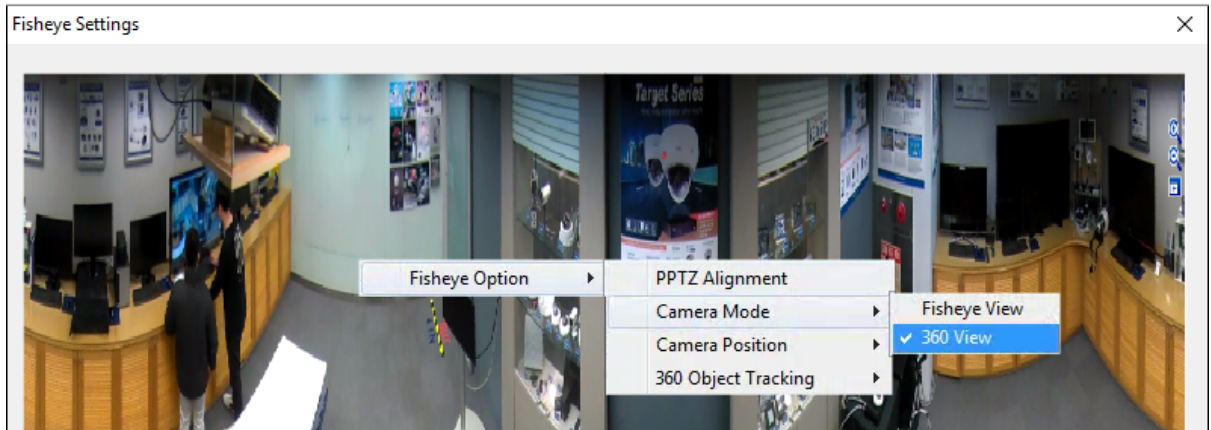

Figure 3-88

- Select **360 Object Tracking** and select **Advanced Settings** to customize object tracking. For details, see Step 4 in *Object Tracking, Fisheye View* earlier in this chapter.

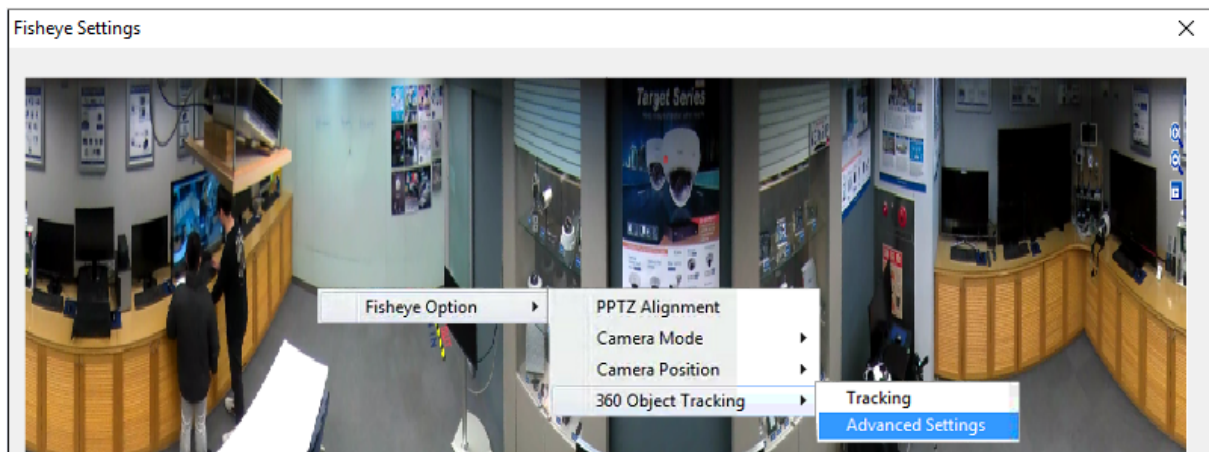

Figure 3-89

- Select **360 Object Tracking**, and select **Tracking** to enable the object tracking function.

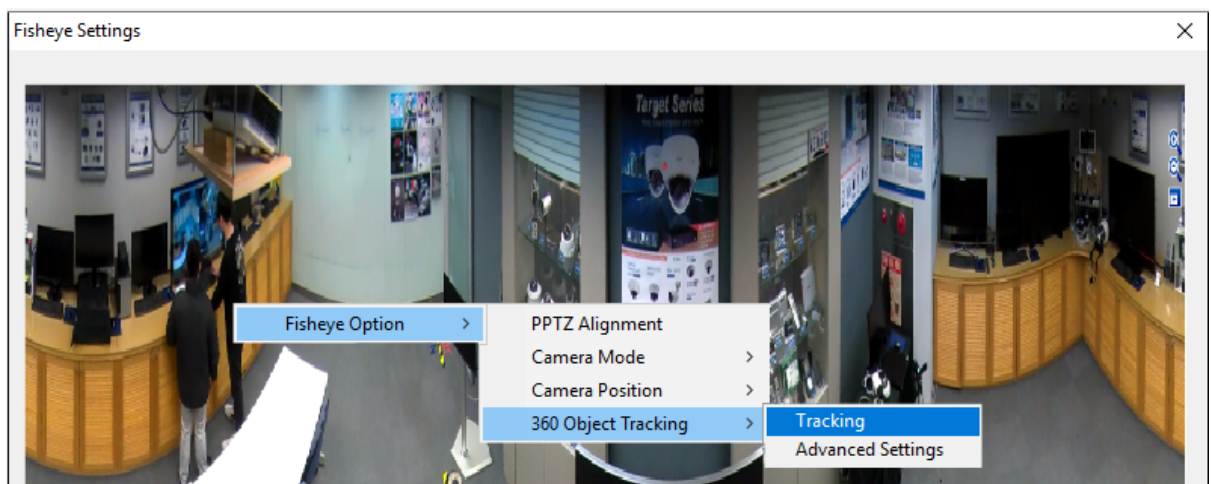

Figure 3-90

3.24 Specifications

Feature		Notes
Panorama View		<ul style="list-style-type: none"> 1 GB of RAM required at minimum 4 sets of panorama view for live view monitoring
Defogging		<ul style="list-style-type: none"> 35 MB of RAM required per channel at minimum Maximum of 64 channels
Stabilizer		<ul style="list-style-type: none"> 34 MB of RAM required per channel at minimum Maximum of 4 channels
Crowd Detection		<ul style="list-style-type: none"> Maximum of 16 channels
Advanced Scene Change Detection / Advanced Unattended Object Detection / Advanced Missing Object Detection		<ul style="list-style-type: none"> Maximum of 16 channels
Object Counting		<ul style="list-style-type: none"> 7 fps and 6 MB of RAM required per channel at minimum Maximum of 32 channels
Privacy Mask		<ul style="list-style-type: none"> 31 MB of RAM required per channel at minimum Maximum of 250 detection boxes can be set The overall size of detection boxes cannot exceed 102400 bytes.
Face Count		<ul style="list-style-type: none"> Maximum of 16 channels
Object Index / Object Monitor / Face Detection		<ul style="list-style-type: none"> 7 fps and 16 MB of RAM required per channel at minimum Maximum of 16 channels
Detection Box Color	Object Counting	Yellow
	Intrusion Alarm	Red
	Object Index	Blue
	Face Count	Green
	Crowd Detection	Blinking red and green
	Advanced Missing Object	Blinking red and green
	Advanced Unattended Object	Blinking red and green

Specifications are subject to change without notice.

Note: To use two or more of the following functions simultaneously, at least 2 GB of RAM is required: Advanced Video Analysis, Video Analysis, IP Camera and Pre-Record by Memory.

Chapter 4

Video Playback.....	173
4.1 Playing back on ViewLog.....	174
4.1.2 ViewLog Control Panel	176
4.1.2 Adjusting the Camera View.....	179
4.1.3 Bookmarking Video Events in ViewLog.....	180
4.1.4 Merging and Exporting Video	181
4.1.5 Saving, Printing & Copying Images	186
4.1.6 Adjusting Distorted Views	187
4.2 Object Search.....	188
4.3 Advanced Log Browser.....	190
4.3.1 Filter Settings	191
4.4 Remote ViewLog Service	192
4.4.1 Retrieving Recorded Videos from GV-VMS	192
4.4.2 Retrieving Images of Object Index.....	193
4.4.3 Recording Backup	193
4.4.4 Exporting and Importing Host List	194
4.4.5 Displaying Sub Stream.....	194
4.5 Single Player	195
4.5.1 Single Player Window.....	195
4.6 Specifications.....	196

Video Playback





Recorded videos can be played back using the following various software applications offered by GV-VMS. Below summarizes their main characteristic to help you decide which application to use under a given situation.

Application	Description
ViewLog	A full-function player to play back video, search a video event, merge and export video and etc. See <i>4.1 Playing Back on ViewLog</i> .
Object Search	A more convenient tool to search video files recorded on motion or alarm. See <i>Object Search</i> in this chapter.
Remote ViewLog Service	A software system to retrieve files from a remote GV-VMS and it supports most functions provided by the ViewLog player. See <i>Remote ViewLog Service</i> in this chapter.
WebCam Server	A server that remotely accesses live view and play back recordings on your Web browser without installing additional software. See <i>Remote Viewing</i> in Chapter 7.
Single Player	A player that plays back the backup recorded files with simple and easy playback functions. See <i>Single Player</i> in this chapter.

4.1 Playing back on ViewLog

ViewLog is a video player that plays back recorded videos without affecting the recording in process.

To launch ViewLog:

1. Select **ViewLog**  > **Toolbar**  > **Content List** . The Content List appears.
2. Select **Add**  > **Import from Live** to import current live views to the playback screen. For details on configuring the ViewLog layout, follow Step 2 to 5 of *Arranging Live View Layouts* in Chapter 1.

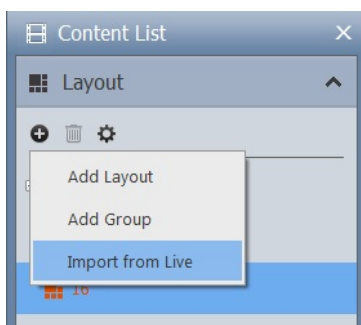

Figure 4-1

3. Optionally drag and drop more cameras from the Content List to the playback screen.
4. On the timeline, click the arrows or click on the date to select a date from a pop-up calendar.

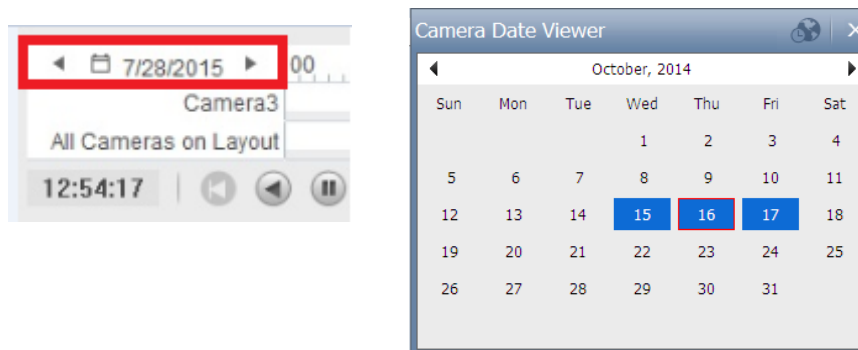



Figure 4-2

5. Click **Play**  to start playing back. For details on ViewLog control panel, see *ViewLog Control Panel* later in this chapter.

4.1.1 ViewLog Window

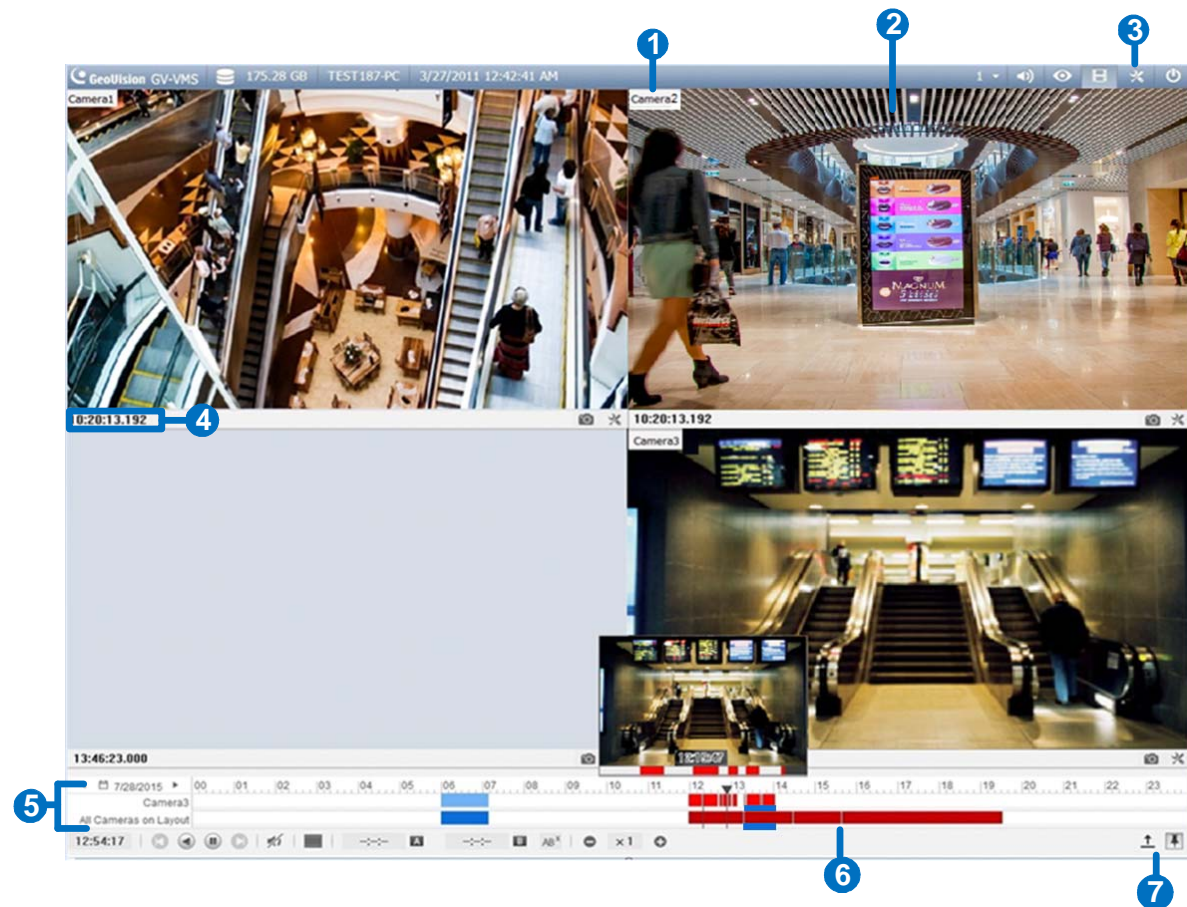

Figure 4-3

No.	Name	Description
1	Camera Name	Indicates the camera name.
2	Camera View	Displays the playback video.
3	Toolbar	Accesses the player's various settings, which are introduced in the following sections. From Setup (Toolbar > Configure), you can enable/disable text overlay and audio timeline during the playback, and configure the size of the Preview window (see <i>ViewLog Control Panel</i> later in this chapter).
4	Recorded Time	Indicates the time of recording.
5	Recording Timeline	Indicates the recording date and reflects video recordings. For details, see <i>ViewLog Control Panel</i> later in this chapter.
6	Playback Panel	Contains typical playback control buttons. For details, see <i>ViewLog Control Panel</i> later in this chapter.
7.	Display All Database	Displays the recording timelines of all camera channels.

4.1.2 ViewLog Control Panel

Preview Window

Move the cursor on the timeline to see a preview of recording. Click on the timeline to pause all channels at the selected time. To change the size of the preview, click **Toolbar** > **Configure** > **Setup**.

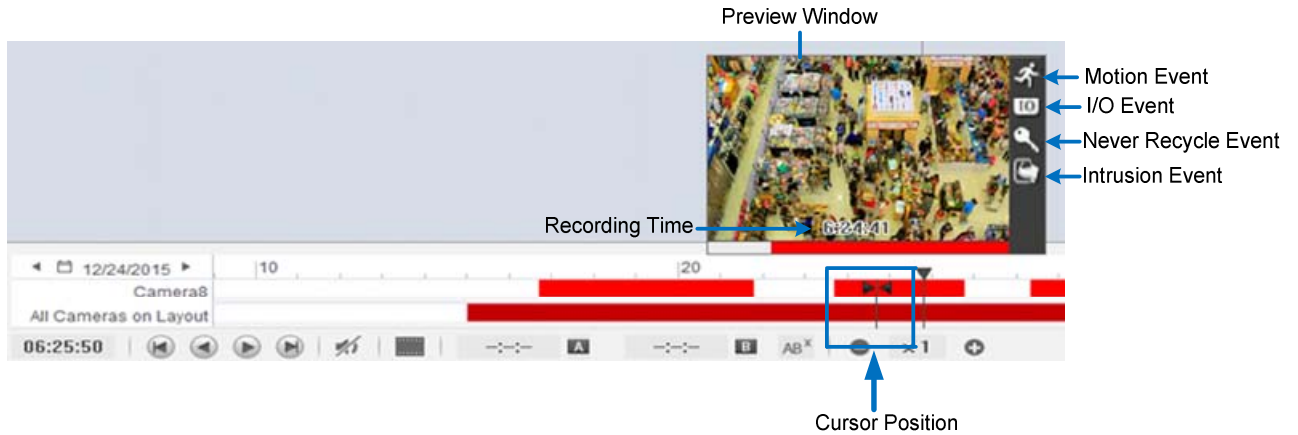

Figure 4-4

Timeline

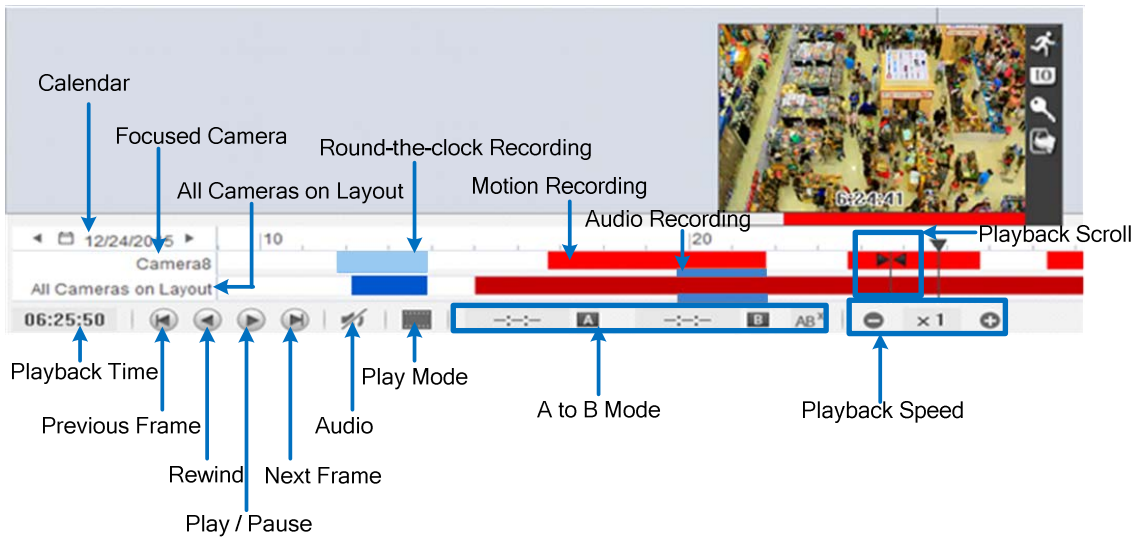



Figure 4-5

Note: Round-the-Clock events are shown as blue, except the following conditions:

1. If the function **Register Motion Event** or **Intrusion** is enabled, the timeline interval of the triggered event becomes red.
2. If the function **Webcam Service** is enabled, the timeline interval becomes red when users log onto GV-VMS remotely (such as using mobile applications).

Tip:

1. Right-click and drag on the timeline to have a quick access to various functions.
2. Click **Display All Database**  to access the timelines of all camera channels.

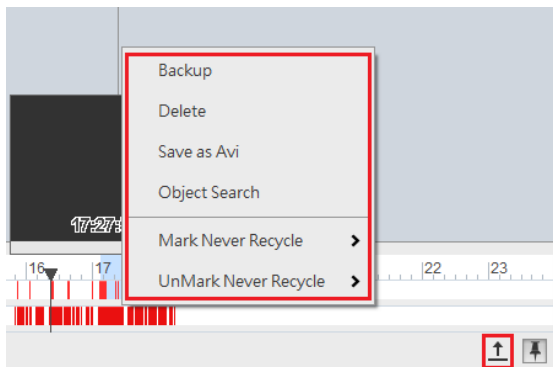
**Figure 4-6**

Playback Mode Option

By default, ViewLog is set to play back video in the Real Time mode. To change playback modes, click  on the ViewLog Control Panel.





- **Frame by Frame (without audio):** Plays back video frame by frame without audio; however, playback can be delayed depending on the bandwidth and computer performance.
- **Real Time:** Plays back video on real time. Despite saving rendering time, this method drops frames.

A to B Playback Mode

When playing video events, you can set a starting and an ending frame for auto-playing:

1. To set the starting frame A, click  and select a time by clicking the timeline. This icon changes to blue and the selected time appears on the ViewLog panel.

**Figure 4-7**

2. Click  and follow step 1 to set the ending point (frame B).
3. Click  ViewLog starts playing from frame A to B repeatedly.
4. To pause the playback, click . To cancel this playback mode, click .

Changing the Displayed Date on the Recording Timeline

You can directly drag the timeline to search and view recordings of a previous or next day with recorded events.

1. Scroll the mouse wheel forth to enlarge the timeline. The default display of the timeline is 24 hours.
2. Click and drag the timeline back and forth. The timeline jumps between the recording days.



Figure 4-7

4.1.2 Adjusting the Camera View

To adjust the image quality for the recorded videos, right-click on the camera view or click **Tools**  to access these settings:

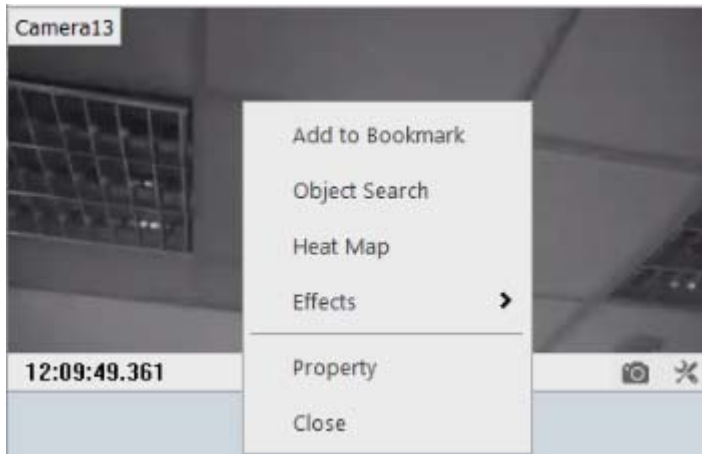



Figure 4-8

- **Object Search:** See *Object Search* later in this chapter.
- **Heat Map:** See *Accessing the Heat Map in Recordings*, in Chapter 3.
- **Effects:** Click to apply image effects.
 - ⊙ To take a snapshot of the current playback image, select **Copy** and then open a WORD or Paint file to paste and save the image.
 - ⊙ To undo the last enabled effect, click **Undo To Prev Action**. To restore to its original video settings, click **Undo All Effects**.
- **Property:**
 - ⊙ **Show Caption:** Enabled by default. Shows the camera name.
 - ⊙ **Keep Image Ratio:** Change the camera view to its original ratio.

4.1.3 Bookmarking Video Events in ViewLog

You can bookmark desired recordings on ViewLog player.

1. Right-click a camera view and select **Add to Bookmark**.
2. To access all the bookmarks, click **Toolbar**  > **Tools**  > **Bookmark**. Double-click any bookmark to move to the corresponding position on the timeline with Playback Scroll.

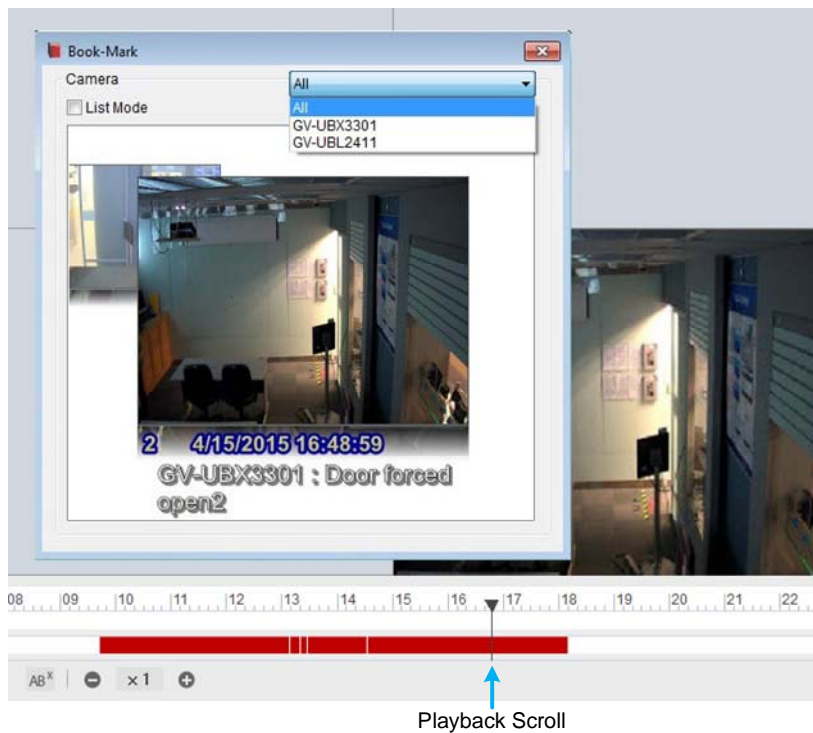

Figure 4-9

3. You can select **List Mode** to present all the bookmarks in a list.

Note: The bookmarked video events will be marked as Never Recycle in ViewLog.

4.1.4 Merging and Exporting Video

You can merge several videos into a single AVI or EXE file and export it to the local computer.

Note: The maximum size of the exported file is 2 GB. Any file exceeding 2 GB will be split into another file. A maximum of 16 channels are supported for merging and exporting multiple videos.

1. Click **ViewLog**  > **Toolbar**  > **Tools**  > **Save as Avi**. This dialog box appears.

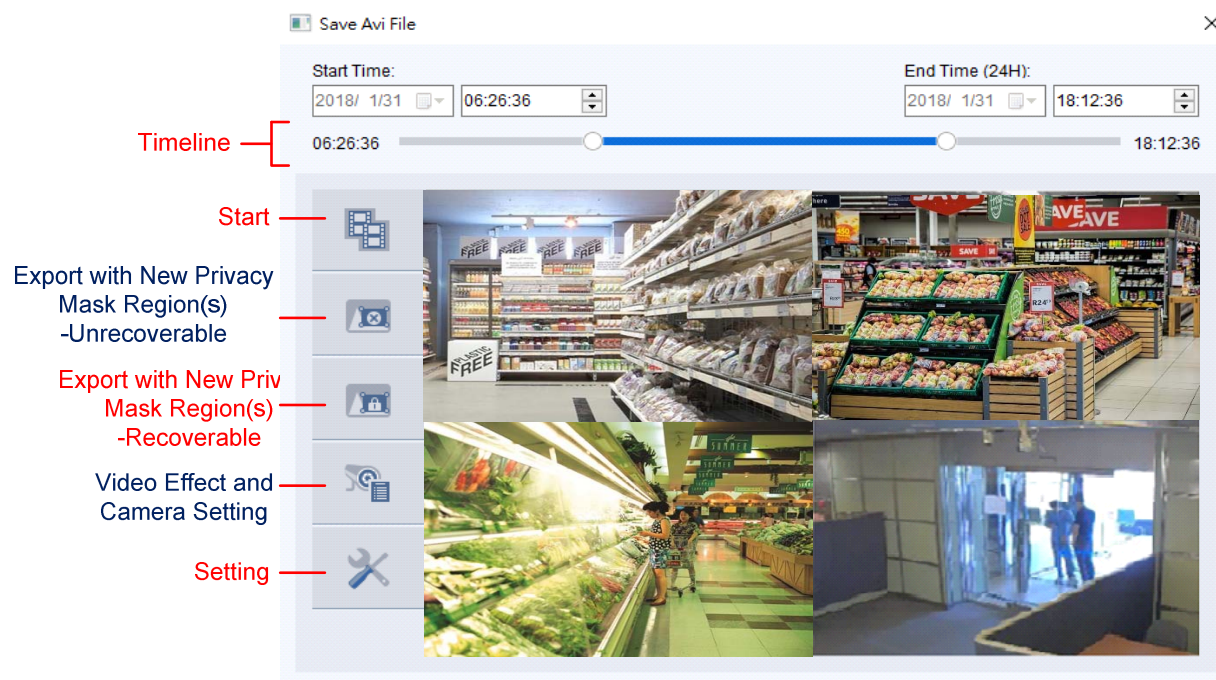



Figure 4-10

2. Click **Video Effect and Camera Setting** to select the camera channel(s) you wish to export.
3. Drag the timeline to define a starting and ending time of the video(s) to be exported.

4. To configure the saving path and format of the exported video, click **Setting** . This dialog box appears.

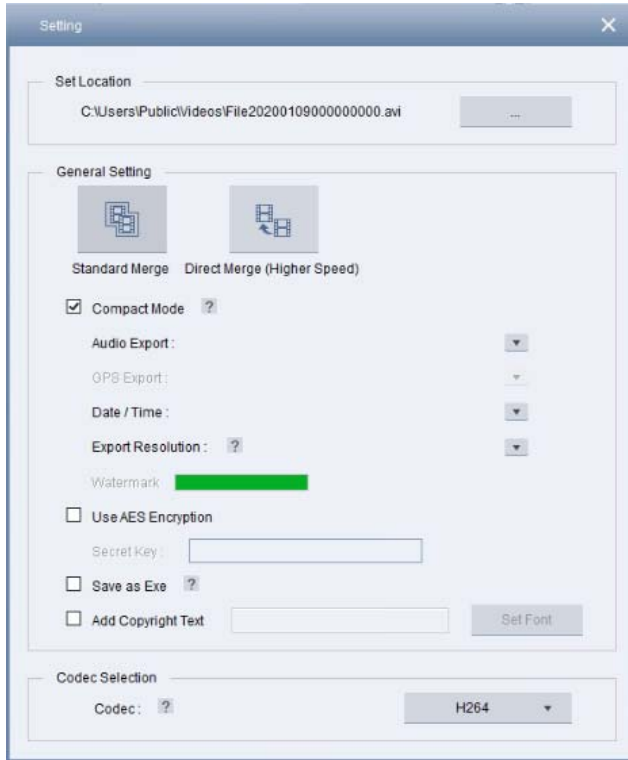

Figure 4-11

[Set Location] Click [...] to assign a saving path.

[General Setting]

- **Standard Merge:** Save a full-length video, containing the images of a single camera or multiple cameras within ViewLog, with recorded and non-recorded periods. A blank blue screen will be displayed during the non-recorded periods. By default, **Compact Mode** is selected to merge only the periods with recorded images.
- **Direct Merge (Higher Speed):** Only available when exporting the videos of one channel. It speeds up the video merging process and saves the video files in the codec in which it was originally recorded. By default, **Compact Mode** is selected to save compact video files by only exporting the key frames.

Note: When using **Direct Merge (Higher Speed)**, the conversion time is significantly reduced, but you will not be able to customize the following settings: codec selection, privacy mask recoverability and digital watermark.

- **Audio Export:** Select **Denoise** to remove audio noises from the video, or select **Channel** for audio exporting.
- **Date / Time:** Select whether to show date and / or time stamps. You can also select the stamp position, font type and size and text color on the images.
- **Export Resolution:** Select a resolution for the exported video.
- **Watermark:** Only available when the watermark is applied to the recorded video. Select to include the watermark in the exported video.
- **Use AES Encryption:** Select and type a 16-digit **Secret Key**, containing only letters and numbers, to add additional security protection for the exported video.
- **Save as Exe:** Select to save files in EXE format to auto-play the files with any third-party player. Enable this feature to play back video at the computer without installing GeoVision codec.
- **Add Copyright Text:** Only available on GV-VMS V18.1 or later, select to stamp user-defined copyright texts to the recording being exported.
 - ⊙ **Set Font:** Click to set the font type and size as well as the position of the copyright text on the recording image.

[Codec Selection]

- **Geo H264:** A codec created by GeoVision which provides better image quality, higher frame rates and smaller file size than other standard codecs. When selected, the GeoVision codec must be installed on the computer playing the exported video. Otherwise export the files in EXE format to play the video at any computer.
- **WMV9 or H.264:** A codec widely used and allowing users to play the video with Windows Media Player or other third-party video players without using GeoVision codec. When selected, the Privacy Mask you created in **Save as AVI** will be disabled.

5. Click the **Start** icon  to start exporting.

To optionally include other features in the exported video, refer to the following:

Configuring Privacy Mask

To configure the Privacy Mask settings for the exported files, click **Setting** and change the Codec to **Geo H264**.



Figure 4-12

- **Unrecoverable privacy mask:** The block-out area(s) marked in black will not be retrievable in the exported files.
- **Recoverable privacy mask:** The block-out area(s) marked in red can be retrievable with the administrator's ID and password.

To set up the block-out area(s), click and drag on the image and select **Add** or **Delete**.

Combining Special Effects

To combine special effects to the exported video, click the **Video Effect + Camera Setting** icon and select the desired effects for each of the cameras selected.

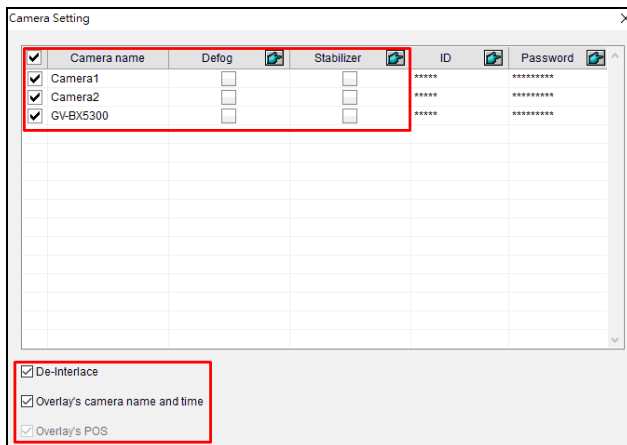

Figure 4-13

Retaining Recoverable Block-out Areas

For recorded videos with Privacy Mask settings, by default, you can see the recoverable block-out area(s) created in Main System when logging in with the administrator account. To retain the block-out area(s) before exporting recorded videos, type a random ID and password in the fields or leave the fields blank. For details on Privacy Mask, see *Privacy Mask Protection* in Chapter 3.

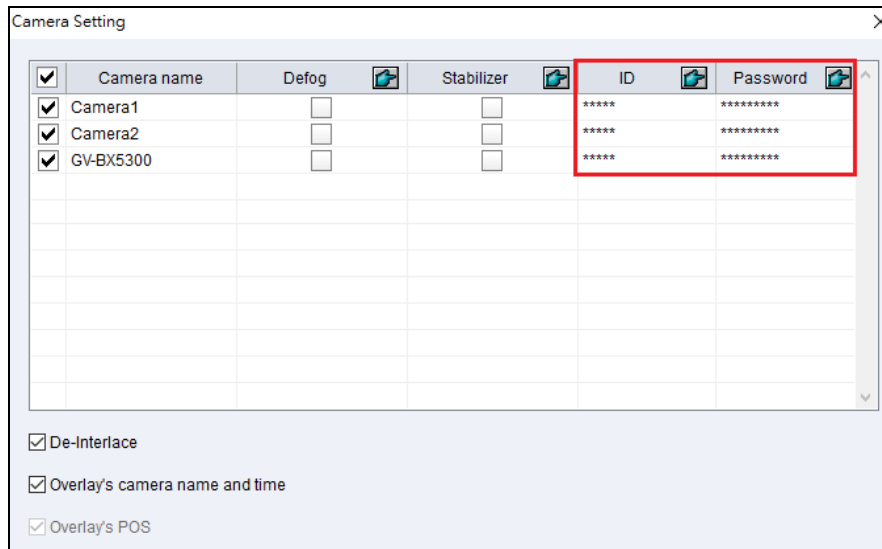

Figure 4-14

Note: Only the administrator can set up the ID and password to retrieve or retain the recoverable block-out area(s). To grant access right to Power Users and Users, see *Granting Access Privileges to Recoverable Areas* in Chapter 3.

4.1.5 Saving, Printing & Copying Images

You can take a snapshot and save, print or copy the current camera view as an image while the recorded video is being played back.

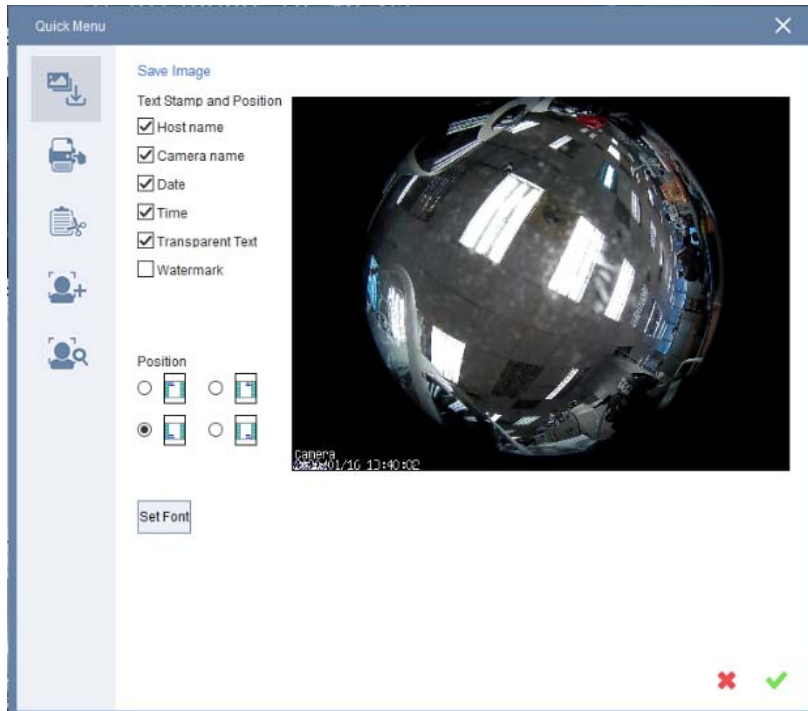







Figure 4-15

1. Click  from a camera channel on ViewLog. The Snapshot Quick Menu appears.
2. Select the **Save Image** , **Print**  or **Copy Image**  tab, to respectively save, print or copy the snapshot captured.





[Stamp Text on the Image] Select to add text(s) to the image. Selecting **Transparent Text** will create the stamps in transparent text.

[Position] Select a desired position, upper-left, upper-right, bottom-left or bottom-right, where the texts will be added to the image saved.

[Set Font] Click to adjust the font style and/or size of the texts to be added.
3. Click .
 - A. For saving image, type a desired name, select a file format, assign the location to save the image file and click **Save**.
 - B. For printing, optionally add a template or change the size of the image and its position on the page.

4.1.6 Adjusting Distorted Views

When viewing videos on the ViewLog player, images may be curved near the corners. Correct this distortion using the Wide Angle Lens Dewarping feature.

1. Click **ViewLog**  > **Toolbar**  > **Configure**  > **Effect** > **Wide Angle Lens Dewarping**.
2. Select the cameras to apply Wide Angle Lens Dewarping.
3. To adjust the degree of adjustment, click the  button. This dialog box appears.

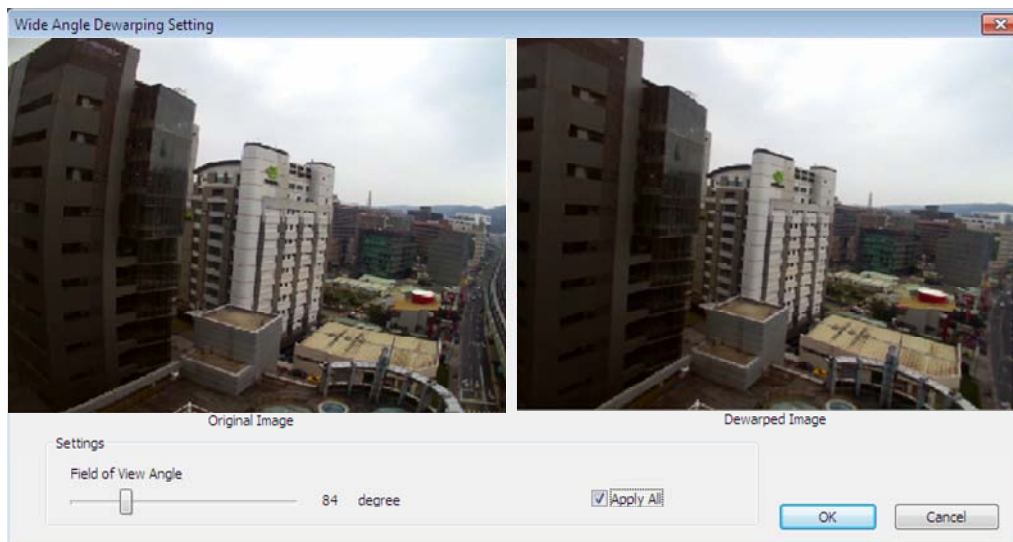





Figure 4-16

4. Move the slider to adjust the degree of warping. The adjusted view is shown on the right.
5. Select **Apply All** to apply the setting to all the cameras selected.
6. Click **OK**. The cameras are immediately dewarped.

4.2 Object Search

Object Search allows you to perform two functions: 1. Detect motion, missing objects or unattended objects to the recorded videos of a camera within a selected day. 2. Perform the counting function to the recorded videos of a camera within a selected day. The following instruction is an example of how to detect unattended events in the recorded files.

1. Select **ViewLog** , click the desired channel and select **Toolbar**  > **Tools**  > **Object Search**. This window appears.

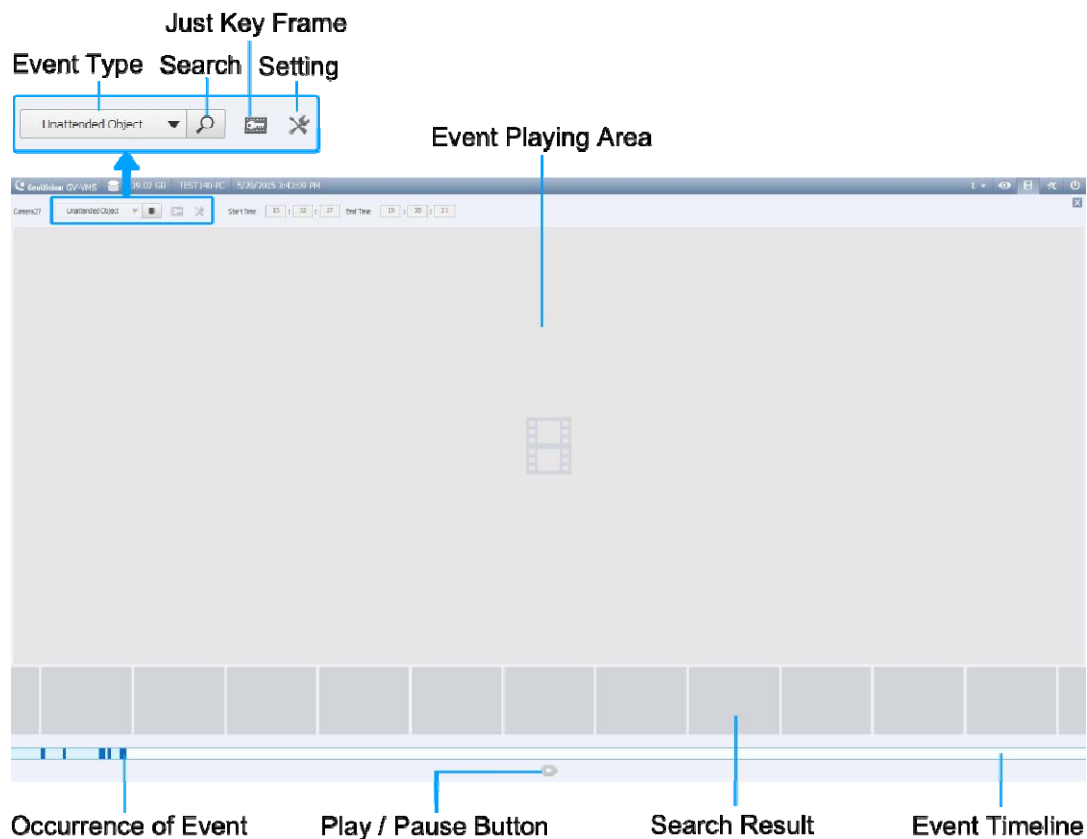



Figure 4-17

2. Select an event type from the drop-down list .
3. Click **Setting** .
 - a. Select to detect objects by region or object size.
 - b. Draw an area on the right image to define the detection zone and object size.
 - c. Adjust the **Sensitivity** if needed.

d. Click **OK**.

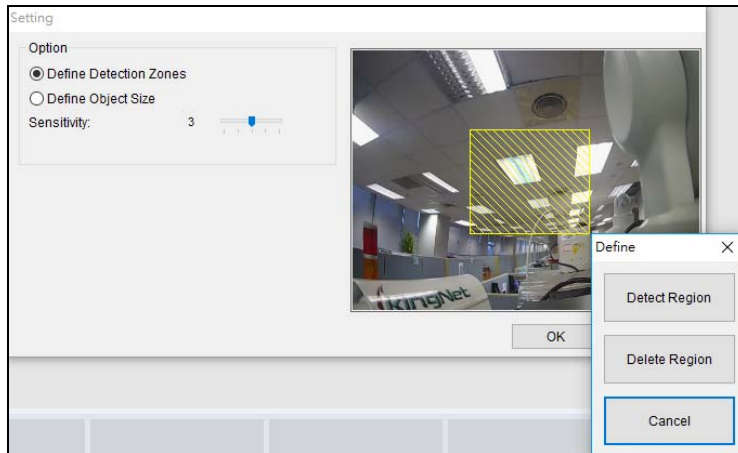

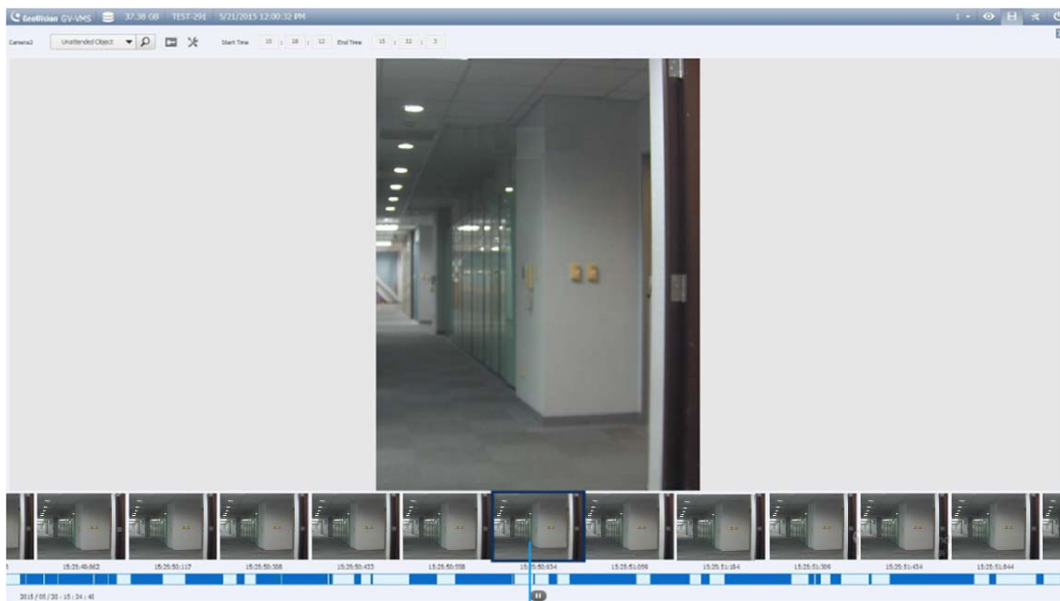

Figure 4-18

4. Click **Just Key Frame**  to search only key frames if necessary. Click **Search**  and the search results are shown in blue on the event timeline below.
5. Move the cursor on the timeline to find a desired result. Double-click an event or click the **Play** button to view the event.



Corresponding Search Result

Figure 4-19

4.3 Advanced Log Browser

With the Advanced Log Browser, you can search for log data of monitored events, system activities, user activities, and Object Counting events. For details on the log types, see *System Log* in Chapter 1.

1. Click **ViewLog** > **Toolbar** > **Tools** > **System Log** > **Advanced**. The Open Database dialog box appears.
2. Specify a time range and click **OK**. All events within the specified range are displayed on the Advanced Log Browser window.

Controls on the Advanced Log Browser

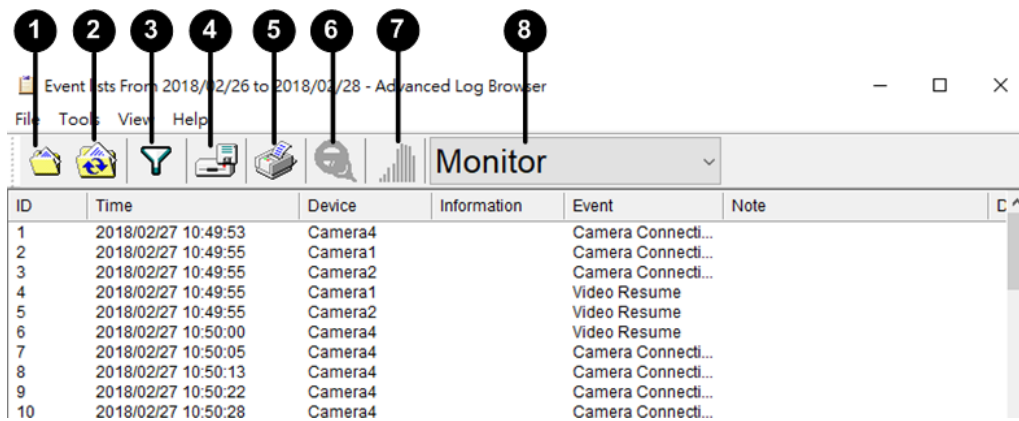

Figure 4-20

No.	Name	Description
1	Open	Opens an event log.
2	Reload	Select Reload All Table or Reload Current Table to refresh loaded data.
3	Filter	Defines the search criteria. See <i>Filter Settings</i> later in this chapter.
4	Backup	Select All Tables to back up all log data, or selects Current Table to back up the current log table you are at. By default, audio and video are enabled for backup.
5	Print	Prints the current log table.
6	Filtering / Cancel Filtering	Only available when filtering starts. Click to cancel the filtering. After the filtering is complete, this icon appears dimmed.
7	Counter Table	Only available when selecting Counter as the Log Type. Click to display the sums of the In and Out counting numbers of cameras with counting function.
8	Log Type	Select to display log of the following type: monitor, login, system, counter, merge, delete, backup, I/O, notifications, playback, CMS, and POS.

4.3.1 Filter Settings

You can define filter criteria to search the desired log data. You can also import pre-defined filter settings for log search, or save current filter settings for future use.

1. On the toolbar, click the desired log table button (Monitor, System, Login or Counter), click the **Filter** button (No. 3, Figure 4-20), and select **Default Filter**. This dialog box appears.

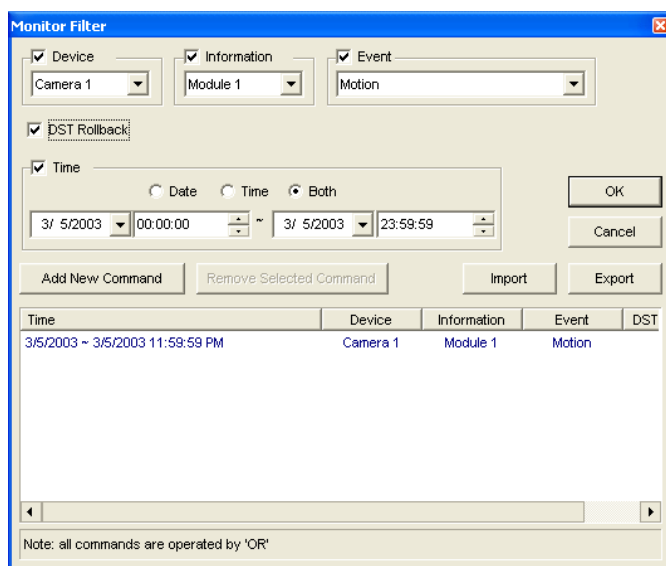

Figure 4-21

2. Define the filter criteria, such as a specific camera and a period of time.
3. To search the log data recorded during the Daylight Saving Time period, select **DST Rollback**.
4. To add more filter criteria, click **Add New Command** and repeat Step 2.
5. You can click **Export** to save the current settings to another location, or **Import** to apply other filter settings.
6. Click **OK** to display the filter results.

Tip: Next time when you want to use the same exported settings, just click the **Filter** button, select **Favorites**, and select the name of the export file.

Note: The default Export path is **:GV folder\Syslog_Favorites\Monitor**. If you change the saving path, the name of the export file will not be listed in the **Favorites** option.

4.4 Remote ViewLog Service



You can retrieve the files from a remote GV-VMS through the network using the Remote ViewLog Service.

GV-Remote ViewLog V2:

- supports most of the functions provided by ViewLog, such as Backup, Save as AVI, Object Search, Database Files Backup. For details on how these functions might work, refer to the configurations of ViewLog in the earlier sections of this chapter.
- is capable of disabling camera connections under heavy network load
- can back up recordings from a remote GV-VMS

Note: GV-Remote ViewLog V2 has enhanced user interfaces compared to previous GV-Remote ViewLog. Currently, not all the features in GV-Remote ViewLog are available on GV-Remote ViewLog V2.



4.4.1 Retrieving Recorded Videos from GV-VMS

1. Download **GV-Remote ViewLog V2** to a computer from [GeoVision's website](#).
2. On GV-VMS, click **Home**  > **Toolbar**  > **Network**  > **Control Center Server** > **Remote ViewLog Service** to allow remote access.
3. Execute GV-Remote ViewLog and create a Remote ViewLog account. After creating an account, the Add New Host dialog box will appear.
4. In the Host Type, select **DVR / NVR / VMS**.
5. Type the **Location Name** (for reference), **IP Address**, **Account** and **Password** of the GV-VMS. Only modify the default port 5552 if necessary.
6. Click **OK**.

When the connection is established, you will see the events from the remote GV-VMS appearing on the Event List. Then you can use ViewLog features for playback.

4.4.2 Retrieving Images of Object Index

The images of Object Index include the **Object Index**, **Face Detection** and **Video Snapshot**. With the Remote ViewLog Service, you can retrieve all the Object Index images from a GV-VMS through the network.

1. On the toolbar, select **Tools**  > **Search Object Index**.
2. On the Object Index Search window, select the desired camera and file date for playback.
3. Click the **Refresh** button  to refresh the date and time.
4. To play images with the ViewLog player, double-click the desired frame on Object Index List.

4.4.3 Recording Backup

Using the Remote ViewLog Service, you can back up files from a remote GV-VMS. When the file transfer is interrupted by a network error, you can even resume backup.

1. To back up the recordings, on the toolbar, select **Tools**  > **Backup**. See *Backing Up Recorded Files* in Chapter 5 for related backup settings.
2. When the backup is interrupted, this message will appear: *There are x file(s) couldn't be backup. Do you want to keep a log file and backup them later?*
3. Click **Yes**. You will be prompted to save the partial backup file as *lv format.
4. To resume backup, click the **Resume** button at the bottom of the Backup dialog box and locate the partial backup file to continue.

For details on backing up files, see *Backing Up Recorded Files* in Chapter 5.

4.4.4 Exporting and Importing Host List

You can export and import the host list to and from another GV-Remote ViewLog. Click the **Tools** button under Camera List to access these functions.

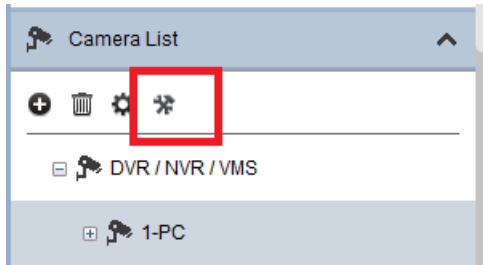



Figure 4-22

4.4.5 Displaying Sub Stream

To reduce network latency when playing back multiple channels, you can choose to display the sub stream of smaller image size from the connected hosts if the dual-stream recordings are available. To do so, on the toolbar, click **Display**  > **Display Dual Stream First**.

4.5 Single Player

When backing up the recorded files, you can choose to include the player of ViewLog or Single Player (see *Backing up Recorded Files* in Chapter 5). Compared to ViewLog, the Single Player provides simpler and easier playback functions. To play back the recorded videos using the Single Player, open the backup folder and run **GVSinglePlayer.exe**.

4.5.1 Single Player Window

Click **Files** > **Open File** to select the file you wish to play back. To play back multiple recorded files together in up to 16 screen divisions, click **Files** > **Open Folder** to select the folder that collects several camera recordings.

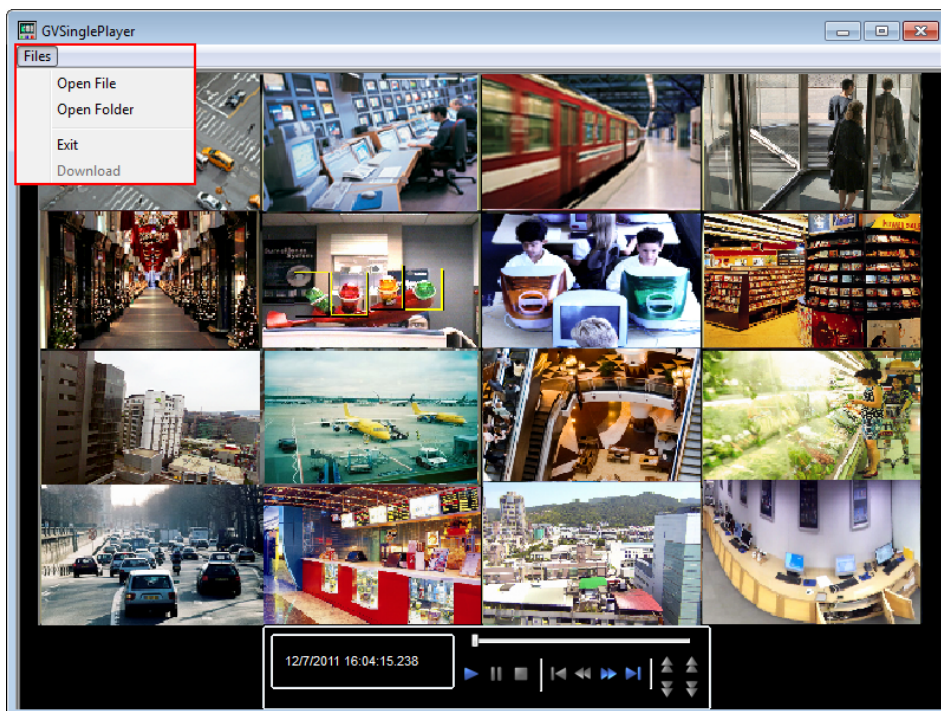

Figure 4-23

4.6 Specifications

Feature	Notes
Support for Defogging	Yes (64 channels)
Support for Stabilizer	Yes (64 channels)
Support for PIP View	Yes
Support for PAP View	Yes
Support for Panorama View	Yes (4 sets of Panorama View)
Videos Exported as .AVI Files	Yes
Object Search	Yes
Support for Fisheye View	Yes

Chapter 5





Backup, Deletion and Repair.....	198
5.1 Backing up Log Data	198
5.2 Backing up Recorded Files	199
5.3 Deleting Recorded Files.....	202
5.4 Repairing Damaged File Paths.....	203
5.5 Repairing Damaged Video Files.....	204

Backup, Deletion and Repair

This chapter explains how to back up and delete video/audio files on the hard disk. Video files can be copied to external storage media, such as CD-R, DVD, MO, or ZIP drives.

5.1 Backing up Log Data

Using the System Log, you can back up all log data or filtered data based on criteria.

1. Click **ViewLog**  > **Toolbar**  > **Tools**  > **System Log > Advanced**. The Open Database dialog box appears.
2. Specify a time range and click **OK**. Events recorded during the specified range are displayed on the Advanced Log Browser window.
3. Click **Backup**  on the toolbar. The Customer Database Export dialog box appears.
[Table Option] Select **All Tables** to back up all log data or **Current Table** for the log table you are currently at.
[Export with Video/Audio data] Backs up video/audio attachments with log data.
4. Click **OK**. The Backup dialog box (Figure 5-1) appears.
5. In the Media section, select the method and destination to back up the log files and click **OK** to back up.

Note:

1. To back up the filtered data, use the **Filter** function to define search criteria first. See *Filter Settings, Advanced Log Browser* in Chapter 4.
 2. To open the backup data, run **EZSysLog.exe** from the backup file.
-

5.2 Backing up Recorded Files

1. Click **ViewLog**  > **Toolbar**  > **Tools**  > **Backup**. This dialog box appears.

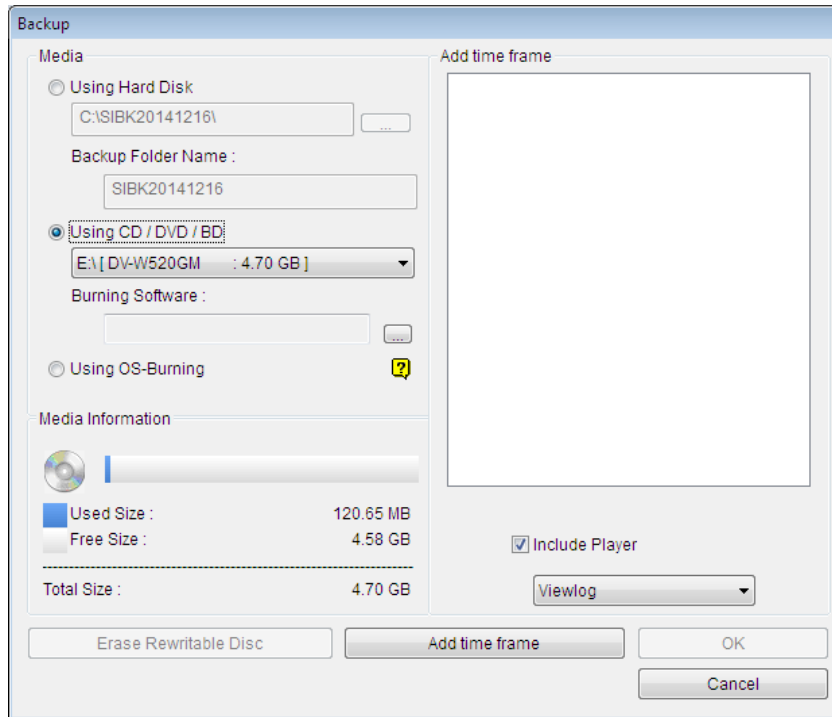

Figure 5-1

2. Select a destination media to back up files.

[Media]

- **Using Hard Disk:** Click the [...] button to select the desired hard disk.
- **Backup Folder Name:** Type a desired name for the backup folder.
- **Using CD/DVD/BD:** Click to back up files to the CD or DVD media using the third-party software.
 - Click the [...] button to assign the desired burning software (.exe file). After clicking **OK** on the Backup dialog box (Figure 5-1), the system will ask you to paste the backup files to the CDR-Writer program, and call up the assigned burning software for you to paste and backup files.
 - If Nero software of version 6.6.0.14 or later is installed, you can directly burn the files onto CD/DVD without assigning the burning software and pasting the backup files to the CDR-Writer program.
 - If Nero software of version 7.0 or later is installed, you can directly burn the files to blu-ray disc.

- **Using OS-Burning:** It burns files using the inbuilt software of the operation system onto the DVD, CD or blu-ray disc. Note that your hard disk needs at least 1 GB buffer space.

[Media Information] Indicates free and used space on CD/DVD media or the local disk.

3. Click the **Add Time Frame** button to define a time period and which files to back up.

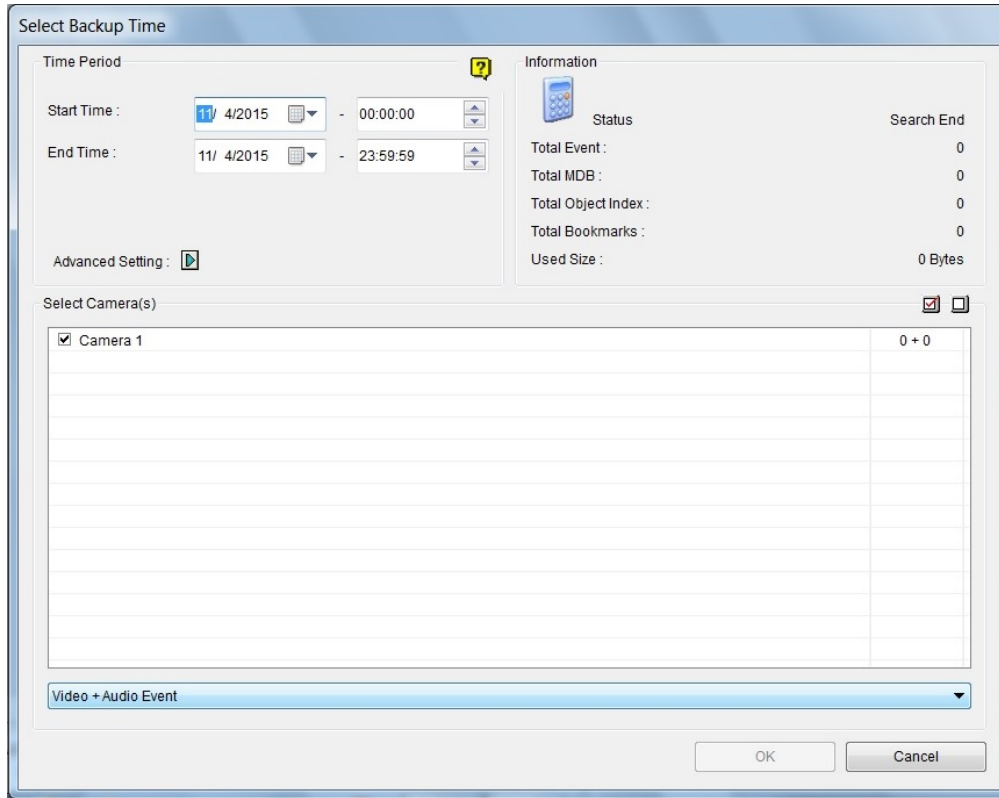



Figure 5-2

[Time Period] Specify the time periods for backup.

[Information] Indicates the number of backup files and their total size. (Total MDB refers to the System Log files.)

[Advanced Setting]: Click  to choose which files to back up:

- **Database Files:** Backs up the files from System Log.
- **Object Index Files:** Backs up the Object Index files.
- **Never-Recycle Events only:** Only backs up the never-recycle events.
- **Unmark these events to be recycled after the backup is complete:** After the backup is complete, the never-recycle events will be unmarked for recycling.
- **Include daylight saving rollback events:** Backs up the events recorded during Daylight Saving Time.
- **Bookmarked files:** Backs up the bookmarked files.

[Select Camera(s)] Select the camera(s) for backup. The number of video and audio files of each camera is indicated respectively, e.g. "Camera 1 1+0" means Camera 1 has 1 video file and 0 audio file.

■ **Video + Audio drop-down list:** Select the types of video events for backup.

4. Click **OK** to add the schedule. You can repeat step 3 to create up to 10 periods of time.
5. To include the player to the backup files, select **Include Player** at the right bottom of the Backup dialog box and select **ViewLog** or **Single Player**. By default, **ViewLog** is selected. If no player is selected, you can only play the backup files at the computer installed with GeoVision codec.
6. Click **OK** on the Backup dialog box to start the backup.

Note:

1. If you are unable to record a CD, make sure the CD recording is enabled in your CD burner: open **My Computer**, right-click the CD Drive icon, click **Properties**, click the **Recording** tab, and check **Enable CD recording on this drive**.
 2. For details on ViewLog and Single Player, see *Chapter 4 Video Playback*.
-

5.3 Deleting Recorded Files

1. To delete files using ViewLog, click **ViewLog**  > **Toolbar**  > **Tools**  > **Delete**. This dialog box appears.

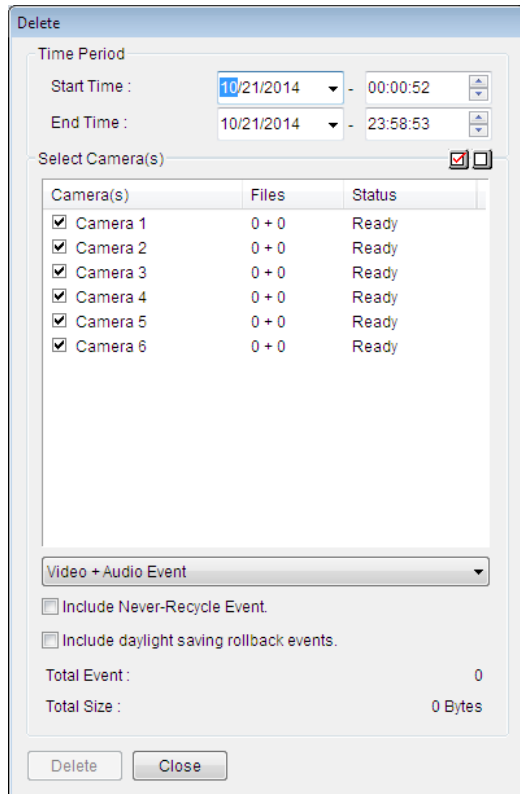





Figure 5-3

2. Define the time period for file deletion.
3. Uncheck the cameras, which you don't want to delete the files of.
4. Use the drop-down list to select the types of events to be deleted, e.g. video, audio or both together.
5. To delete the never-recycle events, select **Include Never-Recycle Event**.
6. To delete the events recorded during the Daylight Saving Time period, select **Include Day Light Saving Time Rollback Event**.
7. Click the **Delete** button.

Note:

1. To view the history of file deletion, click **ViewLog**  > **Toolbar**  > **Tools**  > **System Log > Monitor Table**, and click the **Delete** tab.
 2. To view the storage path and total file size of a camera, right-click the camera and select **Event View** on the Delete dialog box.
-

5.4 Repairing Damaged File Paths

Use GV-VMS' Delete function (see *Deleting Recorded Files* earlier in this chapter) to correctly delete video and audio files. If you move or delete a video file using Windows Explorer or Windows File Manager, GV-VMS will not be able to detect this change. In this case, use Repair Database Utility to repair misplaced or missing recorded files that are not identified by the ViewLog player. As long as these files are still stored on the hard drives and are detectable by Windows operating system, the Utility can restore these recorded files back to their default paths and allow them to appear under ViewLog. This Utility comes with the installation of Main System. Follow these steps to repair the paths:

1. Go to the **Windows Start** menu > **All Programs** > **GV-VMS folder** > **Repair Database Utility**. A valid ID and password are required.
2. When the Select Camera for Repair Database dialog box appears, select the cameras that require database repair and click **OK**. This dialog box appears.

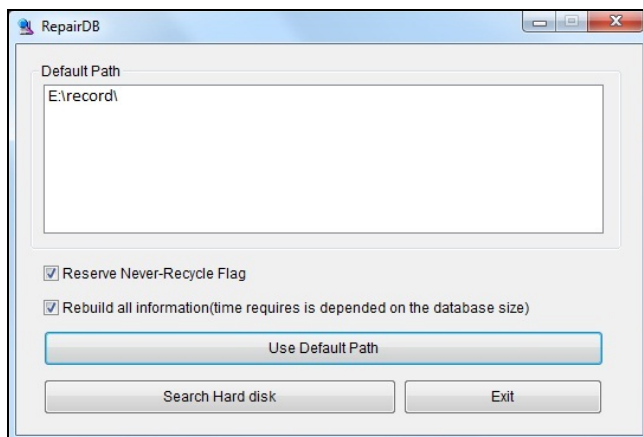

Figure 5-4

3. If your recorded files exist only in the predefined recording path, click the **Use Default Path** button to rebuild the file path in the predefined recording hard drive only.
4. If your recorded files scatter across different hard drives, click the **Search Hard Disk** button to allow more time to rebuild these file paths in all hard drives connected to the GV-VMS.

Note:

1. The repair and the search function will not apply to the files that have been renamed manually.
 2. Use this Utility to repair your database if any of the following scenarios applies to the ViewLog:
 - a. A question mark appears right before a video file in the Video Event list.
 - b. When you select a file and click the **Playback** button, no video is displayed.
-

5.5 Repairing Damaged Video Files

If the computer has been shut down improperly, e.g. due to power failure, use this function to repair the damaged video files.

Tip: When a computer has been shut down improperly, the first thing you do before starting the GV-VMS is to run **Repair Database Utility**. After running the Utility, go back to ViewLog and view Video Events. You should be able to play back all video files at this step. However, if you only see a question mark after clicking on the file, the problem may be that the recording process was interrupted. To repair the file, run the AVI Repair Utility and follow the steps below.

1. Double-click **AVIRepairAPI.exe** in the GV folder. This dialog box appears.

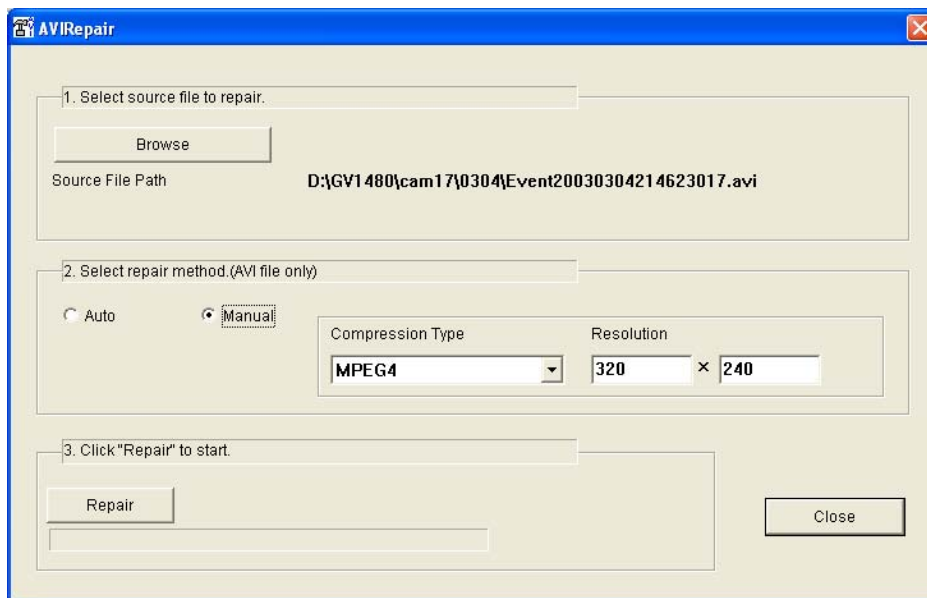

Figure 5-5

2. Click the **Browse** button to find the damaged video file.
3. If you know the codec and resolution of the file, select **Manual**, select **Compression Type** and type **Resolution**. Alternatively, select **Auto** but it takes longer time to repair with this selection.
4. Click the **Repair** button to start.

5. You may see the distorted image or **No Image** on view screen if an incorrect codec and resolution were chosen. Click **No** for the next combination until a complete image appears.

Distorted Image

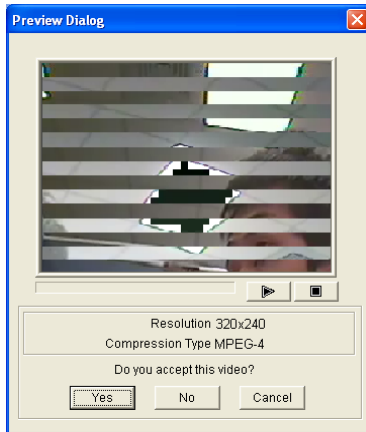

Figure 5-6

No Image

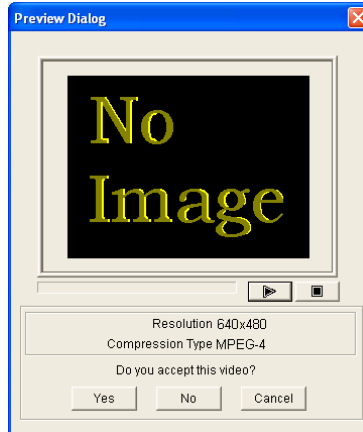

Figure 5-7

Complete Image

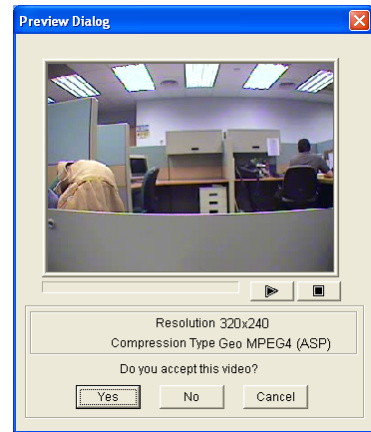

Figure 5-8

6. When a complete image is displayed, click the arrow button to preview the file.
7. Click **Yes** to start the repair.
8. Click **Yes** to overwrite or **No** to save this file to another path. Note if you choose **No** in this step, remember to run **Repair Database Utility** again after exiting this program.

Chapter 6

I/O Applications	207
6.1 Setting I/O Devices	207
6.1.1 Adding I/O Devices	208
6.1.2 Setting the Input and Output Devices	209
6.1.3 Latch Trigger	210
6.1.4 Keeping Last Toggle Status	212
6.1.5 Setting PLC I/O devices	214
6.2 Advanced I/O Applications	216
6.2.1 Setting up Actions upon Input Trigger	217
6.2.2 Moving PTZ Camera to Preset Points upon Input Trigger	218
6.2.3 Setting Momentary and Maintained Modes	219
6.2.4 Deactivating Alarm and Alert upon Input Trigger	220
6.2.5 Other I/O Application Functions	221
6.3 I/O Devices in Content List	222
6.4 Visual Automation	223

I/O Applications

This chapter discusses how you can set up and control the I/O devices connected to GV-VMS. I/O applications include these features:

- Record video, send e-mail notification and trigger output upon input trigger
- Move PTZ camera to a preset location on input trigger
- Support access control systems of Momentary and Maintained modes
- Visual automation to intuitively trigger an output by clicking on the camera view

6.1 Setting I/O Devices

To connect the I/O device to the computer of GV-VMS, you may need additional devices: GV-Net, GV-Net Card, GV-NET/IO Card or GV-I/O Box. For details, visit [GeoVision website](#).

To set up I/O devices on the GV-VMS, click **Home**  > **Toolbar**  > **Configure**  > **Accessories** (if available) > **I/O Device** (if available) > **I/O Device Setup**. This window appears.

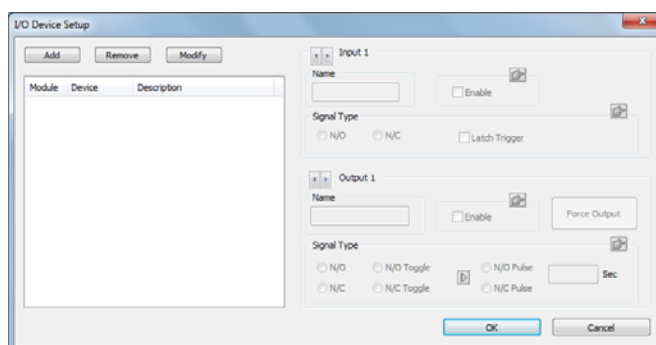

Figure 6-1

Note: The **Accessories** option only appears when GV-Keyboard or GV-Joystick has been set up on the GV-VMS. The **I/O Device** option only appears after at least one I/O device has been added.

6.1.1 Adding I/O Devices

To add an I/O device to GV-VMS, click the **Add** button in I/O Device Setup dialog box.



Figure 6-2

There are three ways to add an I/O device:

- **IO Box (USB):** Select if GV-VMS is connected to the GV-I/O Box through USB connection.
 1. Select the type of **Device** connected.
 2. Select the **COM port** used to connect the device.
 3. Assign an **Addr.** number to the device. Start by setting the first device to 1, and then assign a different address for every new device added.

- **GV IP Device:** GV-VMS can remotely control the I/O devices connected to GV-IP Devices through TCP/IP connection. Select the GV-IP Device with I/O devices installed and click the  button.

- **IO Box (IP):** GV-VMS can remotely control the I/O devices connected to GV-I/O Box through TCP/IP connection.
 1. Click the **Search** button to search for available devices under LAN or click the **Add** button to manually type the connection information of the device.
 2. Select the device and click the  button. Type the **User Name** and **Password** if needed.

6.1.2 Setting the Input and Output Devices

After adding the I/O device, enable the input and output device. For GV-I/O Boxes connected through USB, you can configure the signal type on GV-VMS. For GV-IP Devices and GV-I/O Boxes connected through TCP/IP, you will have to configure the signal type on the device's Web interface.

[Input X] Click the **Arrow** buttons to select the input device and click **Enable**.

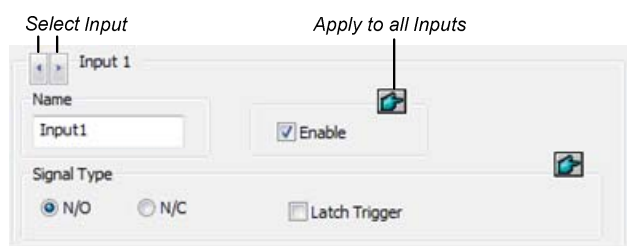

Figure 6-3

- **Name:** Specifies a name for the input device.
- **Signal Type:** Select a signal type for your input device: NO (normally open), NC (normally close) or Latch Trigger. For details on Latch Trigger, see *Latch Trigger* later in this chapter.

[Output X] Click the **Arrow** buttons to select the output device and click **Enable**.

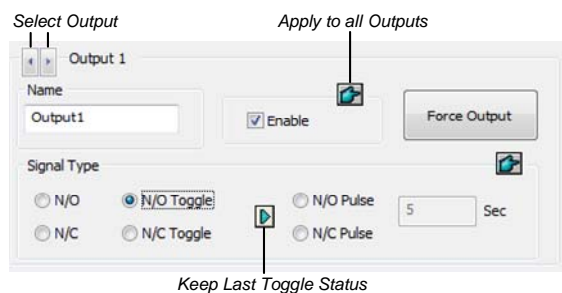

Figure 6-4

- **Name:** Specifies a name for the output device.
- **Force Output:** Click to test signal to the selected device.
- **Signal Type:** Select a signal type: N/O (Normal Open), N/O Toggle, N/O Pulse, N/C (Normal Closed), N/C Toggle, and N/C Pulse. For **Toggle** output type, the output continues to be triggered until a new input trigger ends the output. For **Pulse** output type, the output is triggered for the amount of time you specify in Sec field.
- **Keep Last Toggle Status:** See *Keeping Last Toggle Status* later in this chapter.

Note: PTZ camera and I/O devices cannot be assigned to the same port at the same time.

6.1.3 Latch Trigger

Instead of constant output alarm in N/O and N/C during the input trigger, the Latch Trigger option provides a momentary output trigger.

Setting up Latch Trigger

In the I/O Device dialog box (Figure 6-1), select **Latch Trigger**.

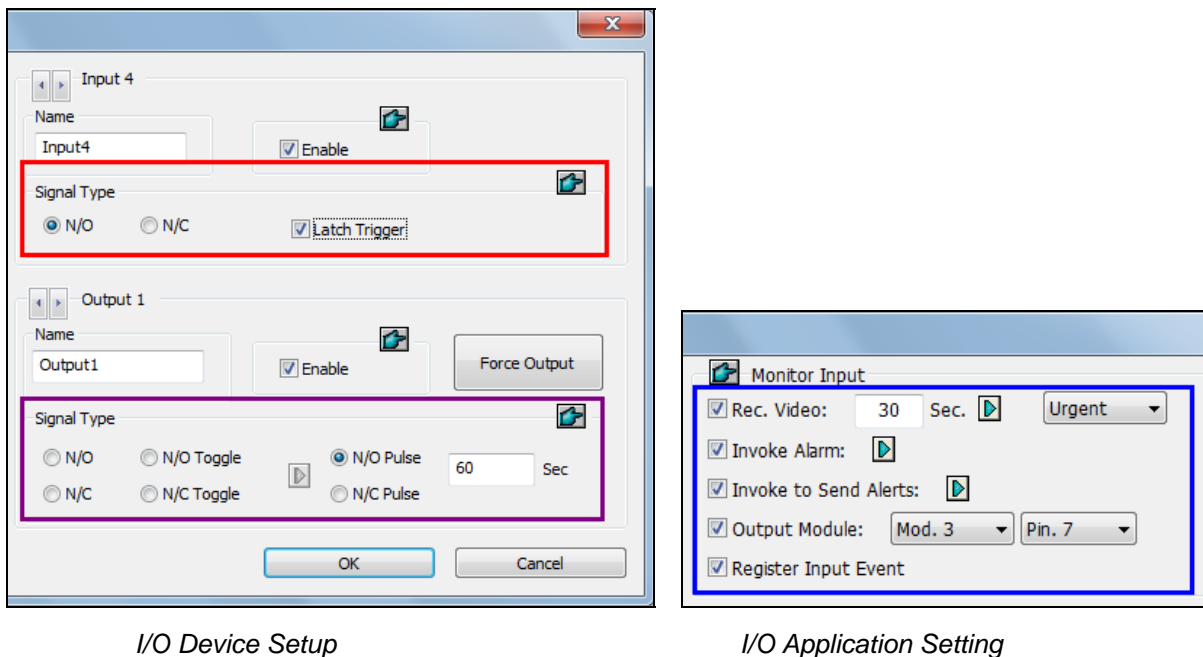

Figure 6-5

Application Example

In the above scenario, Input 4 is set to N/O and Latch Trigger. When Input 4 is triggered:

- The camera starts recording for 30 seconds using the frame rate settings for Urgent Event and stops itself when the next input trigger (see the Rec Video option in the blue box).
- Computer Alarm sounds once (see the Invoke Alarm option).
- The output (Module 3, Pin 7) is triggered simultaneously based on the Latch Trigger mode (see the illustrations below).

The following illustrations can help you understand different output signals (see purple square in the above dialog box) working with the Latch Trigger option.

1. N/O (Normal Open) + Latch Trigger

Once the input triggers the output, the output will be triggered for a short moment and then turn off itself.

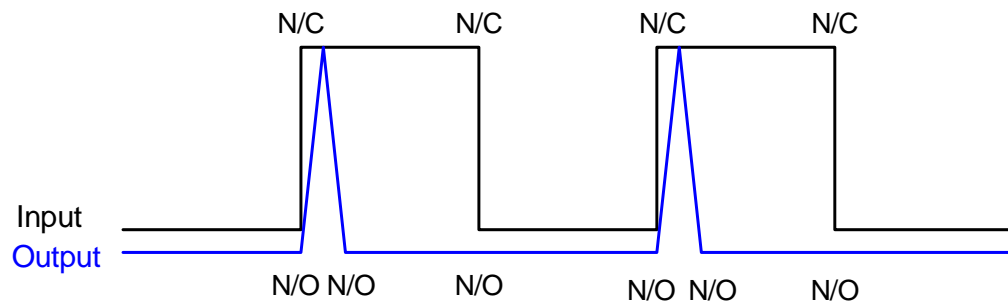

2. N/O Toggle + Latch Trigger

Once the input triggers the output, the output will keep triggering until a new input trigger.

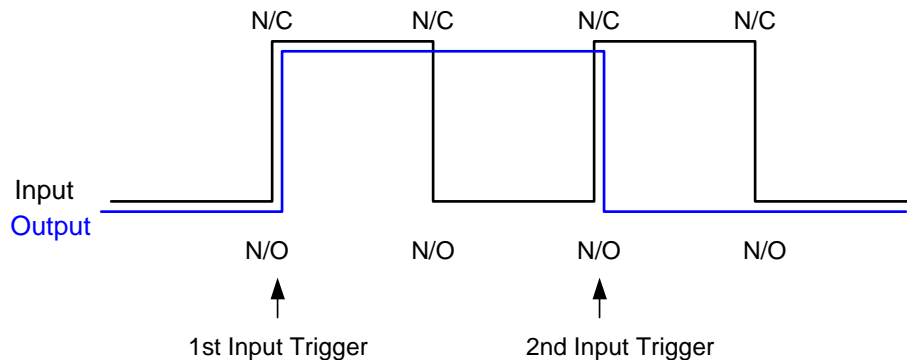

3. N/O Pulse + Latch Trigger

Suppose you set the Pulse time to 60 seconds. Once the input triggers the output, the output will remain ON for 60 seconds before turning off itself.

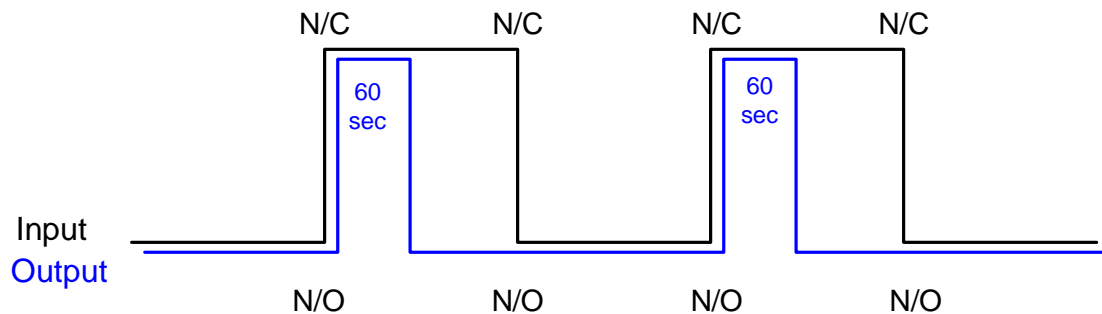

6.1.4 Keeping Last Toggle Status

This feature can memorize the current output state when the monitoring is stopped or the system is restarted. For example, if the output device is a light, the triggered light will remain ON when you stop monitoring.

Setting up “Keep Last Toggle Status”

In the I/O Device dialog box (Figure 6-1), select **N/O Toggle** or **N/C Toggle**, and click the **Arrow** button on the right to select **Keep Last Toggle Status**.

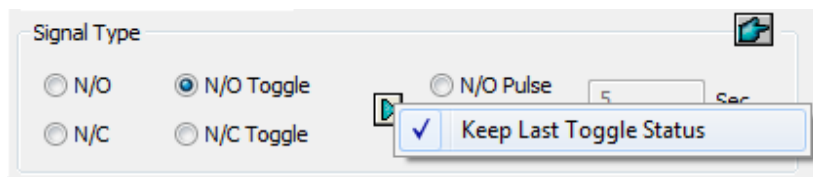

Figure 6-6

Application Example

The following two illustrations explain how the input works with the output set to **Keep Last Toggle Status**.

1. Input (N/O) + Output (N/O Toggle + Keep Last Toggle Status)

The triggered output remains ON even when you stop monitoring or restart the system.

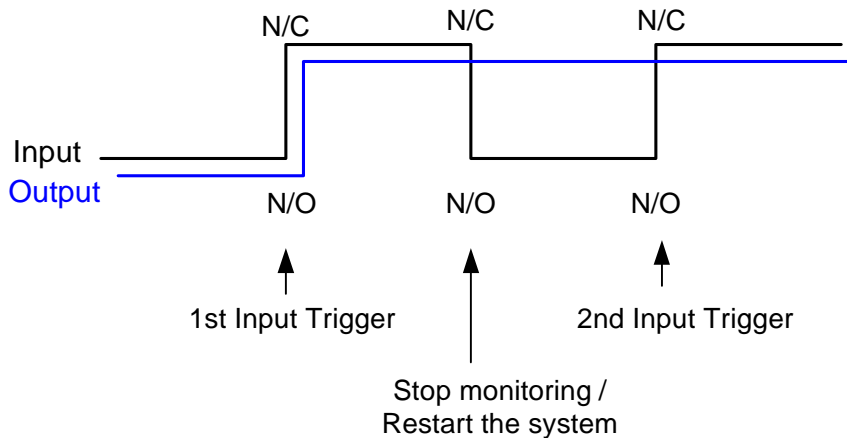

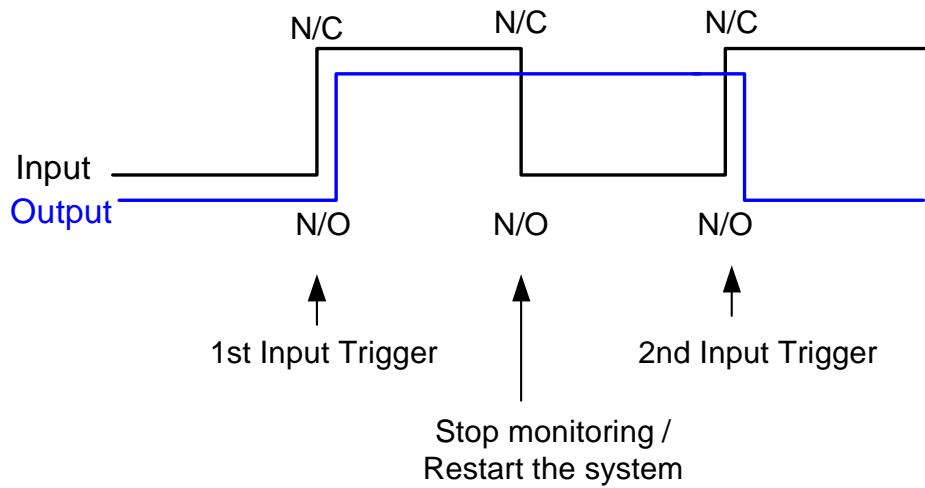

2. Input (N/O + Latch Trigger) + Output (N/O Toggle + Keep Last Toggle Status)

When “Latch Trigger” works with “Keep Last Toggle Status”, the output only has a momentary trigger but also needs to remain ON even when you stop monitoring or restart the system. Therefore under the two conditions, the output turns off when a new input triggers.



6.1.5 Setting PLC I/O devices

1. To connect a PLC I/O device to the GV-VMS, click **Home**  > **Toolbar**  > **Configure**  > **Accessories** > **PLC Device Setup**. This window appears.

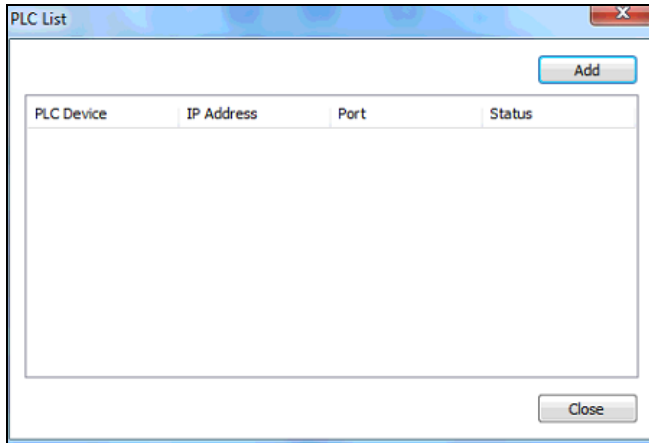





Figure 6-7

2. Click the **Add** button to type the name, **IP Address**, **Port**, **Password**, **M-Pin Range** and select the **Connection Type** of the PLC Device. The M-Pin Range supports up to 999999 pins
3. To bind the M-pins, click **Home**  > **Toolbar**  > **Configure**  > **Accessories**, and select **I/O Device Setup**, When the I/O Device Setup dialog box appears, select the PLC device, click the **Add** button and select **PLC I/O**.

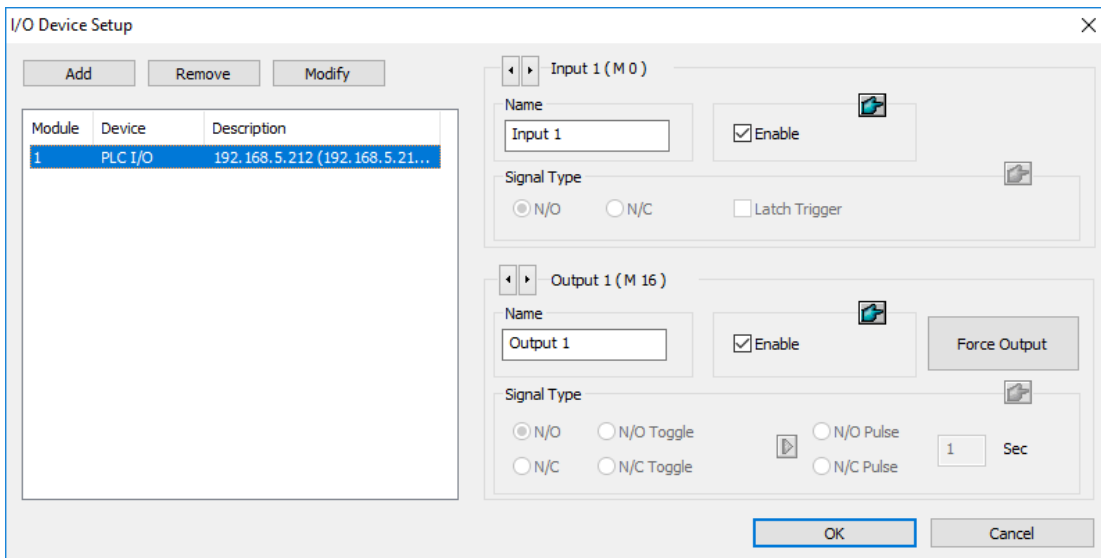

Figure 6-8

4. In the PLC I/O Module Configuration Dialog, drag the pins on the left-hand side to the I/O module on the right-hand side.

Note: Every Input/Output module can only support up to 16 pins. To use other pins, add more I/O modules.

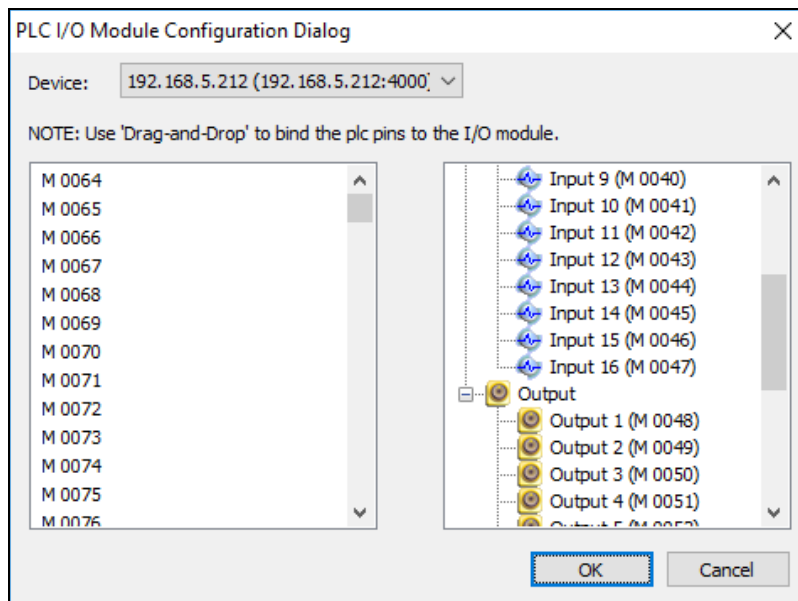

Figure 6-9

6.2 Advanced I/O Applications

After adding I/O devices to GV-VMS, you can configure advanced I/O applications, such as setting alarm notification, defining a PTZ camera movement upon input trigger, setting momentary or maintained mode, and deactivating alarm and alert settings.

Click **Home**  > **Toolbar**  > **Configure**  > **Accessories** (if available) > **I/O Device** (if available) > **I/O Application Setting**. This dialog box appears.

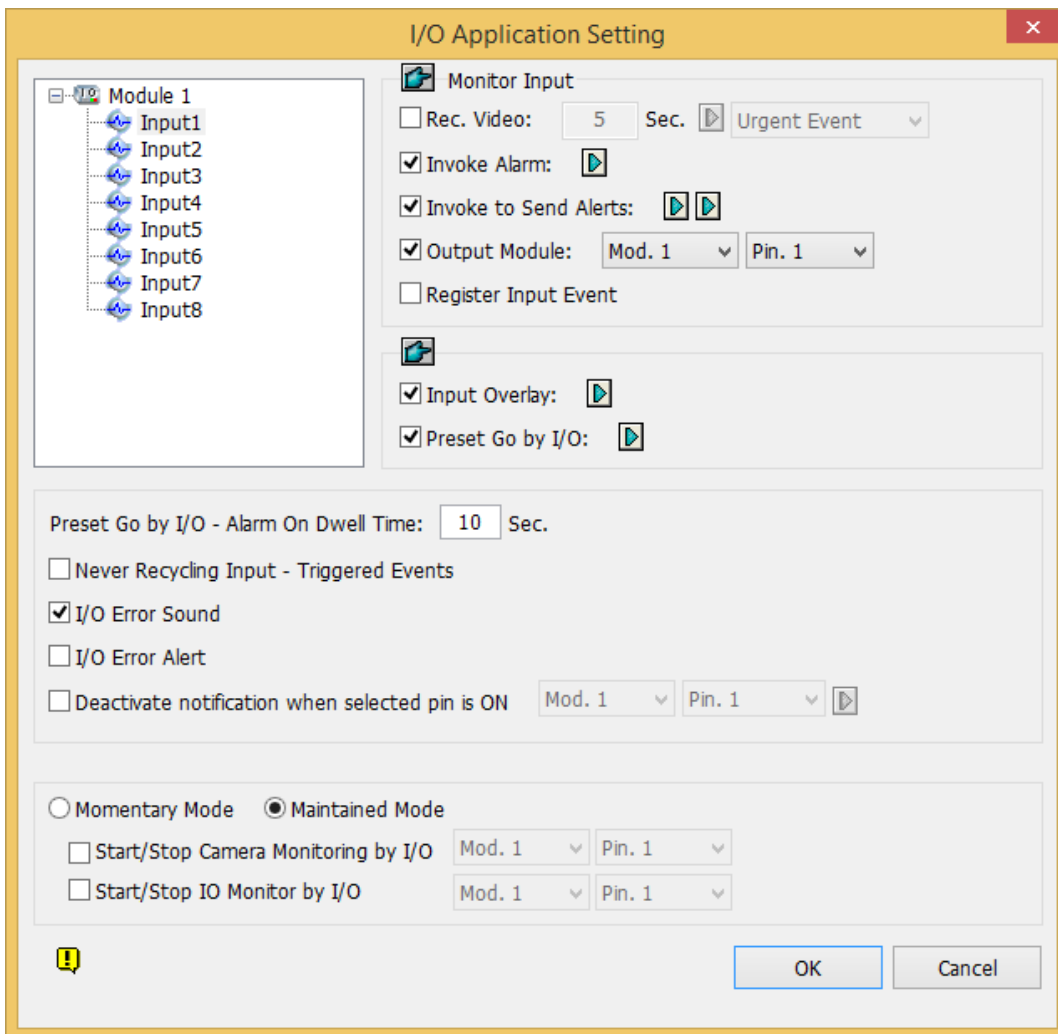



Figure 6-10

Note: The **Accessories** option only appears when GV-Keyboard or GV-Joystick has been set up on the GV-VMS. The **I/O Device** option only appears after at least one I/O device has been added.

6.2.1 Setting up Actions upon Input Trigger

You can set up the actions to take after the input device is triggered. Select an input on the left and clicking the Finger button  will apply the same settings to all inputs.

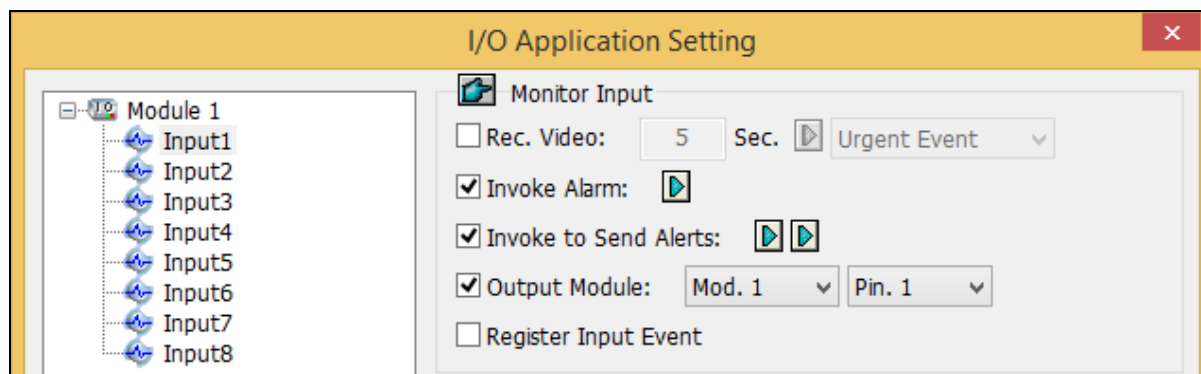

Figure 6-11

[Monitor Input]

- **Rec Video:** Select to record one or multiple cameras upon input trigger. Specify the recording duration and click the **Arrow** button to select which camera to record upon input trigger. Use the drop-down list to select whether to use the frame rate settings for Urgent Event or General Event. For details on setting up Urgent and General Event, see *Configuring General Setting* in Chapter 2.
- **Invoke Alarm:** Select to activate computer alarm when the input is triggered. You can select the alarm sound from the drop-down list.
- **Invoke to Send Alerts:** Select to send out E-mail notification when the input is triggered. Click the **First Arrow** button to select the camera(s). Click the **Second Arrow** button to specify the recipient's email address. For e-mail alerts, see *E-Mail Notification* in Chapter 1.
- **Output Module:** Triggers the specified output module when the input is activated. Use the drop-down lists to select the output module and pin number.
- **Register Input Event:** Registers the I/O trigger events into System Log. Each event is labeled with ID, time, device name (camera or I/O input), corresponding module of the device, and event for later retrieval. For details on System Log, see *System Log* in Chapter 1.

6.2.2 Moving PTZ Camera to Preset Points upon Input Trigger

This feature allows you to move the PTZ camera to preset points when an input is triggered. Select an input number to be set up.

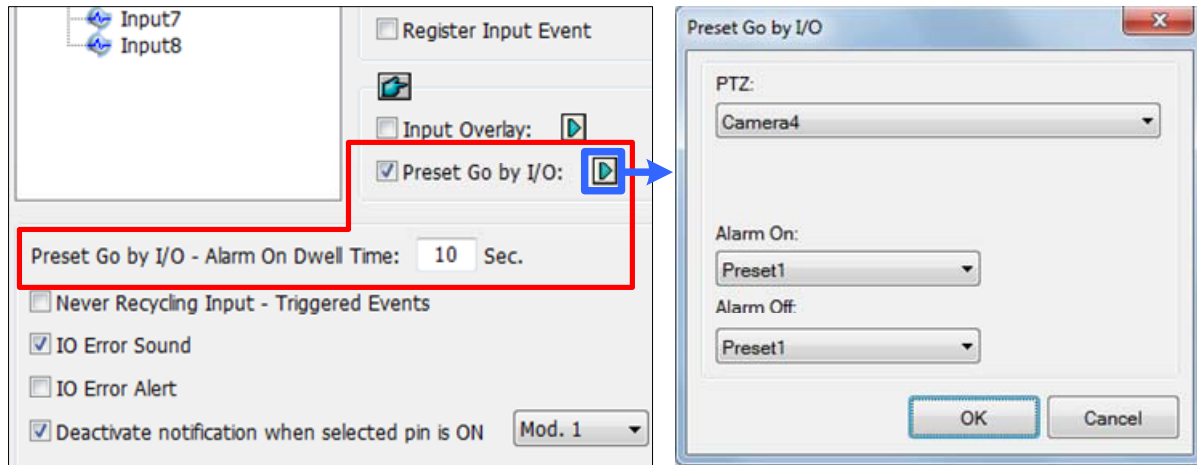

Figure 6-12

- **Preset Go by I/O:** Enable the option and click the **Arrow** button to select your PTZ camera from the drop-down list.
- **Alarm On:** Moves the PTZ camera to a preset point when the input is triggered.
- **Alarm Off:** Moves the PTZ camera to a preset point when the triggered input is off.
- **Preset Go by I/O - Alarm On Dwell Time:** Specify the amount of time the PTZ camera stays at “Alarm On” preset point, before returning to the “Alarm Off” preset point.

Note: Depending on the capability of the PTZ camera, up to 256 PTZ preset points (ranging from 1 to 256) and addresses (ranging from 0 to 255) can be programmed.

6.2.3 Setting Momentary and Maintained Modes



Momentary Mode Maintained Mode
 Start/Stop Camera Monitoring by I/O Mod. 1 Pin. 1
 Start/Stop IO Monitor by I/O Mod. 1 Pin. 1

Figure 6-13

[Momentary Mode] Push button switches that are normally open and stay closed as long as the button is pressed. Momentary switches allow turn-on or turn-off from multiple locations.

For example, certain premises have a designated entry/exit door. When the staff enters the entry door, the system starts monitoring. When the staff leaves from the exit door, the system stops monitoring.

[Maintained Mode] Push-on/push off button switches that stay open until thrown, and then stay closed until thrown again. Maintained switches are convenient for only one switch location.

For example, in the business hour when the door is opened, the system stops monitoring; in the non-business hour when the door is closed, the system starts monitoring.

6.2.4 Deactivating Alarm and Alert upon Input Trigger

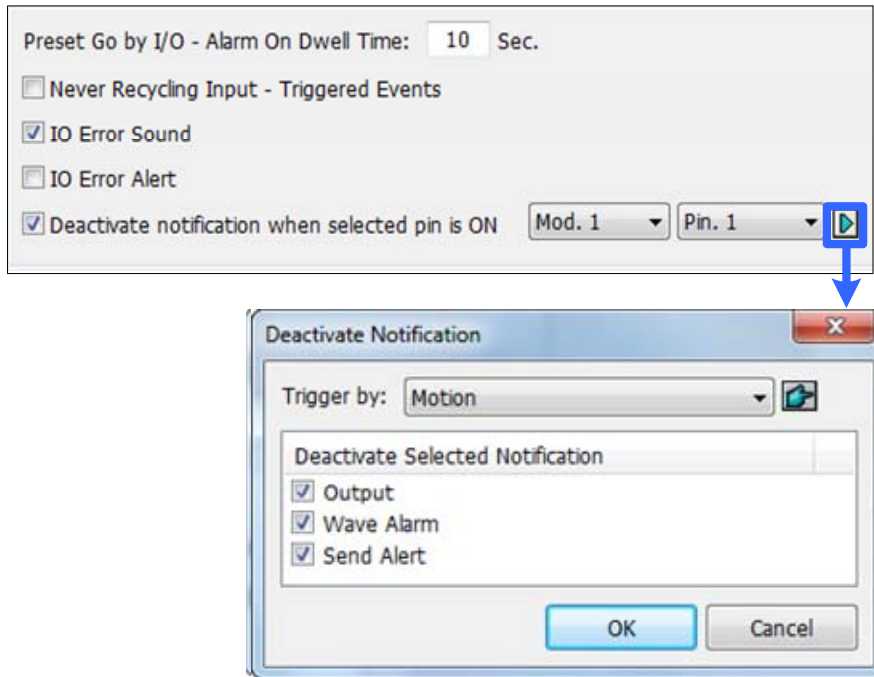

Figure 6-14

[Deactivate notification when selected pin is ON] When an assigned input module is activated, all designated alarms and alerts will be disabled. Assign an installed input module and a pin number for the application.

[Deactivate Notification] Click the **Arrow** button to select the alert to deactivate.

- **Triggered by:** Select an alert condition from the drop-down list for the application. For example, if you choose Motion, all designated alarms and alerts upon motion detection will be deactivated when the assigned input module is activated.
- **Deactivate Selected Notification:** Select the alarms and alerts you want to be deactivated, such as Output, Wave Alarm and/or Send Alert, when the assigned input module is activated.

6.2.5 Other I/O Application Functions

In the I/O Device Application dialog box, you can also set up Input Overlay on live view, alert for I/O errors, and whether to recycle input-triggered events. Select an Input number to be set up.

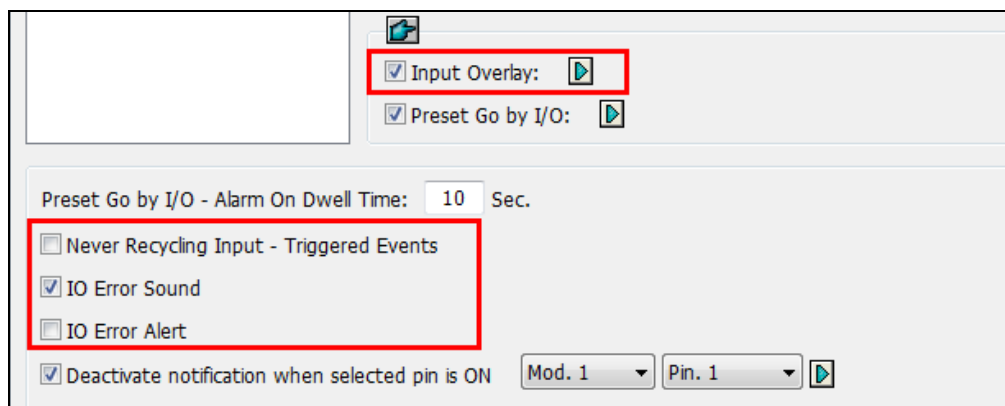



Figure 6-15

[Input Overlay] Select to overlay the name of an input device on live video for alert or save the name to video files upon the input trigger. Click the **Arrow** button to select the camera to overlay input name.

To overlay the name of a triggered input on live video, click **Home**  > **Toolbar** > **Configure**  > **Video Process**. In the dialog box that appears, select **Text Overlay** in the Video Analysis drop-down list, select the camera, and click **Setting**. Select **Print on screen (Only for I/O alarm)** and/or **Print on video file**. Up to 5 input names can be stamped on one camera channel when inputs are triggered.



[Never Recycling Input-Triggered Events] When selected, the files recorded upon input trigger won't be recycled by the system when disk space is full.

[IO Error Sound] When enabled, the computer alarm will sound when GV-VMS fails to detect the connected I/O device.

[IO Error Alert] When enabled, an e-mail notification will be sent when GV-VMS fails to detect the connected I/O device. Remember to set up e-mail notifications. See *Email Notification* in Chapter 1.

6.3 I/O Devices in Content List

When an I/O device is added to the system, the I/O device will appear in the Content List.

1. To display the Content List, click **Home**  > **Toolbar**  > **Content List** .
2. Click **I/O Device** to see the I/O devices added to GV-VMS. When an input or output is triggered, its icon will light up in the I/O Device list.

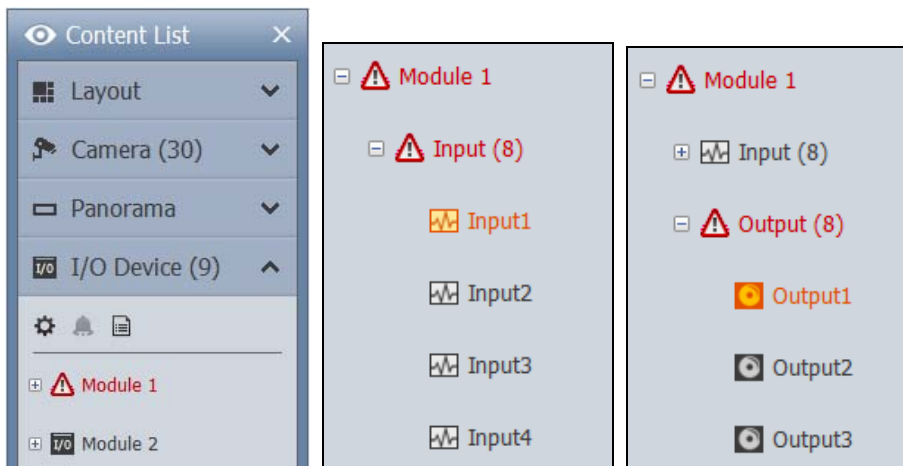





Figure 6-16

3. You can force the output device to be triggered by clicking its icon . Another way to trigger an output is to select an output and click the **Force Output** button .
4. To manually turn off a triggered output, right-click the triggered output in the list and click **Reset**.

6.4 Visual Automation

The Visual Automation helps you automate any electronic device by triggering the connected output. You can then intuitively click on the image of the electronic device, a light for example, to change its current state, e.g. turning the light on.

1. On the main screen, click **Home**  > **Toolbar**  > **Configure**  > **Accessories** (if available) > **I/O Device** (if available) > **Visual Automation Setting**. This dialog box appears.

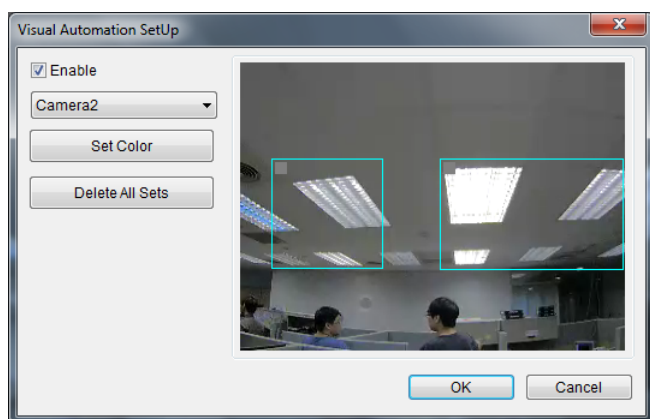

Figure 6-17

2. Select a camera from the drop-down list, and check **Enable**.
3. Drag the region on the camera view. A dialog box appears.
4. Select the connected module and output device. Type a **Note** to help you identify the device.
5. To change the frame color of the set region, click the **Set Color** button.
6. To test the output trigger, click the region on the camera view drawn in Step 3.

To use Visual Automation, on the main screen, move the cursor to the camera view with Visual Automation, click **Tools**  and select **I/O Automation**. Next, click the region you set to trigger the connected output device. You can right-click the camera view and select **Show all** to see all Visual Automation regions if needed.



Figure 6-18

Chapter 7

Remote Viewing.....	225
7.1 Remote Viewing using a Web Browser	226
7.2 WebCam Server Settings	229
7.2.1 General Settings	229
7.2.2 Server Settings.....	230
7.2.3 Video Settings.....	231
7.2.4 Audio Settings.....	232
7.2.5 JPG Settings.....	233
7.2.6 UPnP Settings	234
7.2.7 Network Port Information.....	235
7.2.8 Mobile Service	236
7.3 Single View Viewer	237
7.3.1 Adjusting Video Quality	239
7.3.2 Control Panel.....	240
7.3.3 Configuring Single View Viewer Options.....	241
7.3.4 PTZ Control Panel.....	244
7.3.5 Visual PTZ Control	245
7.3.6 I/O Control	246
7.3.7 Visual Automation	247
7.3.8 Picture-in-Picture View.....	248
7.3.9 Picture-and-Picture View	249
7.4 Multi-Window Viewer	250
7.5 JPEG Image Viewer.....	251
7.6 Playing Back Events.....	252
7.6.1 Event List Query.....	252
7.6.2 Remote Playback	253
7.7 Remote ViewLog	254
7.8 Download Center	255
7.9 GV-Edge Recording Manager.....	256
7.10 Mobile Phone Applications	257
7.11 Web Browsers on Smartphones	257

Remote Viewing

With Microsoft Internet Explorer, you can remotely view live video, download and play back video files, manage systems within the security network, and control PTZ camera and I/O devices through the WebCam Server.

The remote computer used to access live video must meet the following minimum requirements:

OS	32-bit	Windows XP / Vista / 7 / 8 / 8.1 / 10, Windows Server 2008
	64-bit	Windows 7 / 8 / 8.1 / 10, Windows Server 2008 R2 / 2012 R2
CPU		Core 2 Duo, 3.0 GHz
Memory	Windows XP	2 x 1 GB Dual Channels
	Windows Vista / 7 / 8 / 8.1 / 10 / Server 2008 / 2012	2 x 1 GB Dual Channels
Hard Disk		80 GB
Graphic Card		AGP or PCI-Express, 800 x 600 (1280 x 1024 recommended), 32-bit color AGP or PCI-Express, 1024 x 768, 32-bit color (for Multi View Viewer only)
Network		TCP/IP
Web Browser		IE 7.0 or later
DirectX		9.0c

Non-IE browsers, exemplified below, only support single-window remote live view, remote video playback and JPEG image viewer, and system / event log (but unable to play back events from event log). Users can also download **Web Viewer** program from the non-IE browsers to access the complete features as those of Internet Explorer through the program.



Google Chrome	V38.0.2125.111 or later
Mozilla Firefox	V30.0 or later
Microsoft Edge	V20 or later

7.1 Remote Viewing using a Web Browser

The GV-VMS has a built-in WebCam Server that allows you to remotely view and manage the camera images from GV-VMS using a Web browser. Different browsers have slightly different user interfaces.

Note:

1. For Internet connection, the GV-VMS must have an IP address or domain name from ISP. If the IP address is dynamic, you may use the DDNS service to directly change IP addresses to the GV-VMS. For the service, see *Dynamic DNS* in Chapter 9.
2. Make sure the remote PC used to access the GV-VMS meets the recommended system requirements mentioned above.
3. If a router or firewall is installed with the GV-VMS server, ensure the following communication ports required by WebCam Server are open: Command Port (4550), Data Port (5550), Audio Port (6550) and HTTP Port (80).

-
1. To enable the WebCam Server on GV-VMS, click **Home**  > **Toolbar**  > **Network**  > **WebCam Server**. The Server Setup dialog box appears. You can click **OK** to close the dialog box for now and modify the default configurations later.
 2. On a remote computer, open a Web browser and type the IP address or domain name of the GV-VMS. The Webcam Login dialog box appears.

Note: If the default HTTP port 80 has been changed, type a colon and the port number after the IP address, for example, **Http://192.168.3.199:81**.

3. Type the user ID and password of the GV-VMS.

4. Click **Login**. When accessing remote viewing for the first time, you will need to download and install different files for different browsers.

a. For **Internet Explorer**, click the bar at the top of the browser and install plugin.

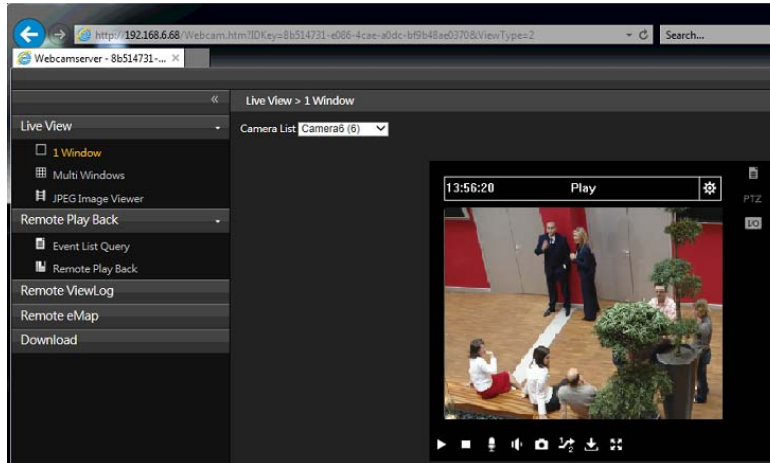

Figure 7-1

b. For **Google Chrome, Microsoft Edge or Mozilla Firefox**, download and run **Web Viewer** from the left menu. After the connection is established, the viewer's user interface is the same as that of Internet Explorer.

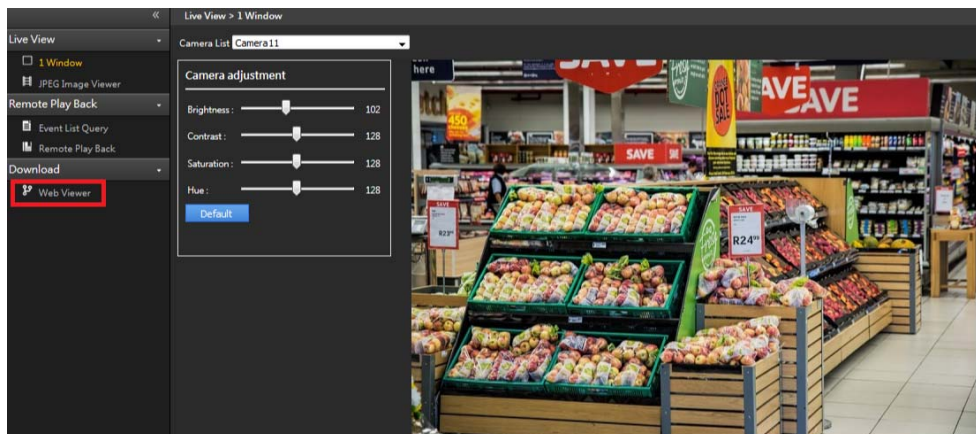





Figure 7-2

The following WebCam Server features are ones that are available on Internet Explorer. For the features available on non-IE browsers, see *Remote Viewing* at the beginning of the chapter.

WebCam Server Features on IE Browser

Name	Description
Live View	Accesses different types of live view viewers. See <i>Single View Viewer</i> , <i>Multi-Window Viewer</i> and <i>JPEG Image Viewer</i> later in this chapter.
Remote Play Back	Accesses remote playback options. See <i>Playing Back Events</i> later in this chapter.
Remote ViewLog	Accesses the Remote ViewLog. See <i>Remote ViewLog</i> later in this chapter.
Remote eMap	Accesses E-Maps remotely set up at the GV-VMS. See <i>E-Map Application</i> in Chapter 8.
Download	Accesses the Download Center. This function offers optional viewing programs to be downloaded to the local PC. See <i>Download Center</i> later in this chapter.

7.2 WebCam Server Settings

To enable and configure the GV-VMS's built-in WebCam Server, click **Home**  > **Toolbar**  > **Network**  > **WebCam Server**.

7.2.1 General Settings

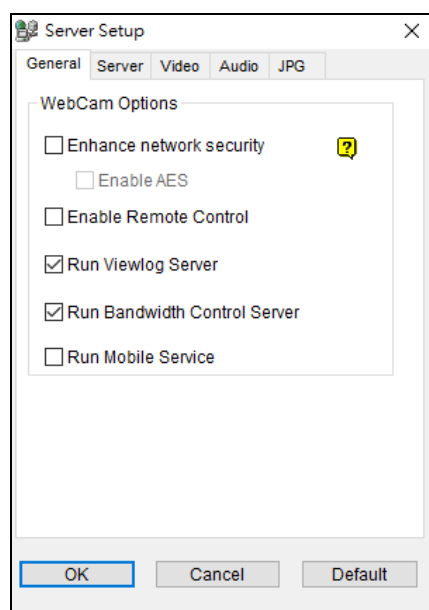

Figure 7-3

- **Enhance network security:** If enabled, a word verification step is required for each WebCam Server's login.
 - ⊙ **Enable AES:** Select to add an additional security protection for live streaming between the GV-VMS and WebCam Server.
- **Enable Remote Control:** Select to remotely configure the I/O devices through the WebCam Server.
- **Run Viewlog Server:** Select to remotely play back video files through the WebCam Server.
- **Run Bandwidth Control Server:** Select to enable the **Bandwidth Control Server**. For details, see *Bandwidth Control Application* in Chapter 9.
- **Run Mobile Service:** Select to enable the mobile function to connect to GV-Eye and GV-Edge Recording Manager (MAC Version).

Note: When **Enhance network security** is enabled, JPEG/Mobile applications will be disabled.

7.2.2 Server Settings

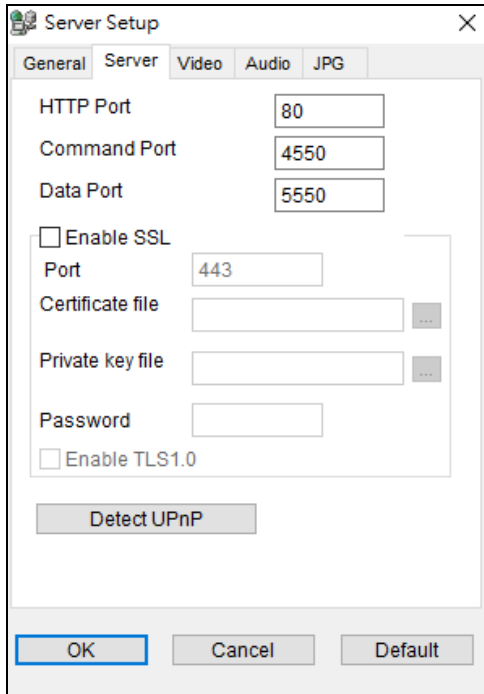

Figure 7-4

- **HTTP Port:** Used to access the Internet. By default, it is 80.
- **Command Port:** Used to access WebCam. By default, it is 4550.
- **Data Port:** Used to transfer data over the Internet. By default, it is 5550.
- **Enable SSL:** Enable the Secure Sockets Layer (SSL) protocol to ensure the security and privacy of Internet connection. To use your own generated Certificate and Private Key or ones verified by SSL authority, click the [...] buttons and select the files stored at your computer. Note that the system will enable both SSL 2.0 and SSL 3.0 as its default; to further enable TLS 1.0 protocol when using SSL protocol, select **Enable TLS 1.0**.
- **Detect UPnP:** For details, see *UPnP Settings* later in this chapter.

Note: If you want to enable SSL 3.0 on a computer running Windows Vista, it is required to upgrade your system to Service Pack 1 or Service Pack 2.

7.2.3 Video Settings

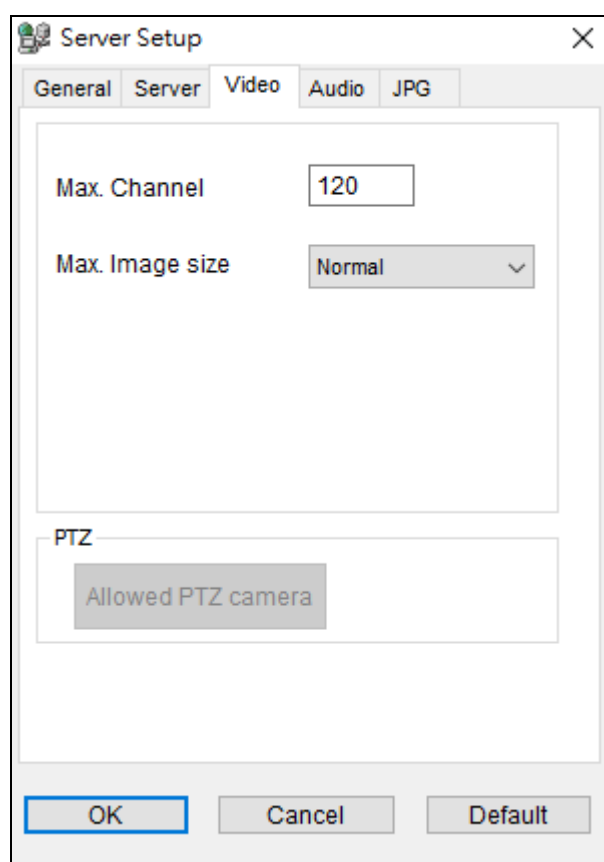

Figure 7-5

- **Max. Channel(s):** Specify the number of channels allowed to access the WebCam Server, with the upper limit of 200 channels.
- **Max. Image size:** Select a maximum resolution allowed for remote access. The default resolution on the WebCam is **Normal** (320 x 240). The other options are **Large** (640 x 480 or 704 x 480) and the **Actual Size** of that IP camera.
- **Allowed PTZ camera:** Controls PTZ cameras at a remote computer. Click the button and select the desired PTZ cameras to allow for remote access.

Note: To specify the time length allowed for a guest user to access the WebCam Server, click the account ID at the top of the main page, click **Password Setup**, and select **Local Account Edit**. In the WebCam tab, select the **Limit Connection Time** option and specify the time length. The time range is between 10 and 3600 seconds.

7.2.4 Audio Settings

Connecting Audio Devices

Through the WebCam Server, you can access live audio at a remote site and talk to the server site when necessary. Before using this feature, make sure all the necessary hardware are in place:

1. To record audio, check the connected IP camera has built-in audio function or an external microphone connected.
2. Check your sound card is already inside the computer. Connect a multimedia speaker to the audio output of your computer's sound card for receiving audio from the remote site.
3. Connect a desktop microphone to the input of the audio extension card (or cable line) for sending audio to the remote site.

Audio Setup

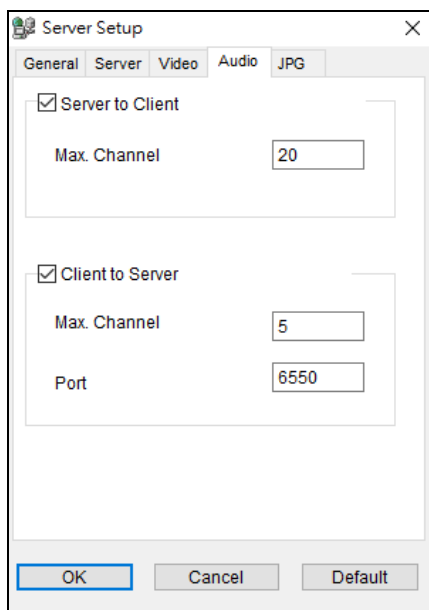

Figure 7-6

[Server to Client] Allows a remote computer to access live audio from the GV-VMS server.

- **Max. Channel(s):** Enter the maximum number of channels allowed to access live audio, with the upper limit of 40 channels.

[Client to Server] Allows a remote computer to speak to the GV-VMS server.

- **Max. Channel(s):** Enter the maximum number of channels allowed to speak to the server site, with the upper limit of 20 channels.
- **Port:** The default audio port is 6550.

7.2.5 JPG Settings

These settings allow you to send JPEG or GIF files over the Internet.

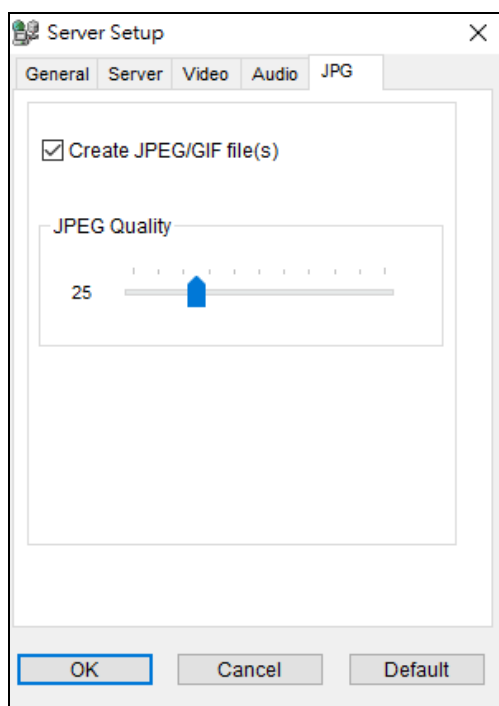





Figure 7-7

- **Create JPEG/GIF file(s):** You can access the JPEG images through WebCam Server, and adjust the image quality. Bigger number results in better image quality and bigger image file size.

7.2.6 UPnP Settings

WebCam Server supports UPnP technology (Universal Plug and Play) to allow automatic port configuration to your router. UPnP must be enabled both on your operating system and your router.

Enabling UPnP on the WebCam Server:

1. On the main screen, click **Home**  > **Toolbar**  > **Network**  > **WebCam Server**. The Server Setup dialog box appears.
2. Click the **Server** tab and click **Detect UPnP**. This dialog box appears.

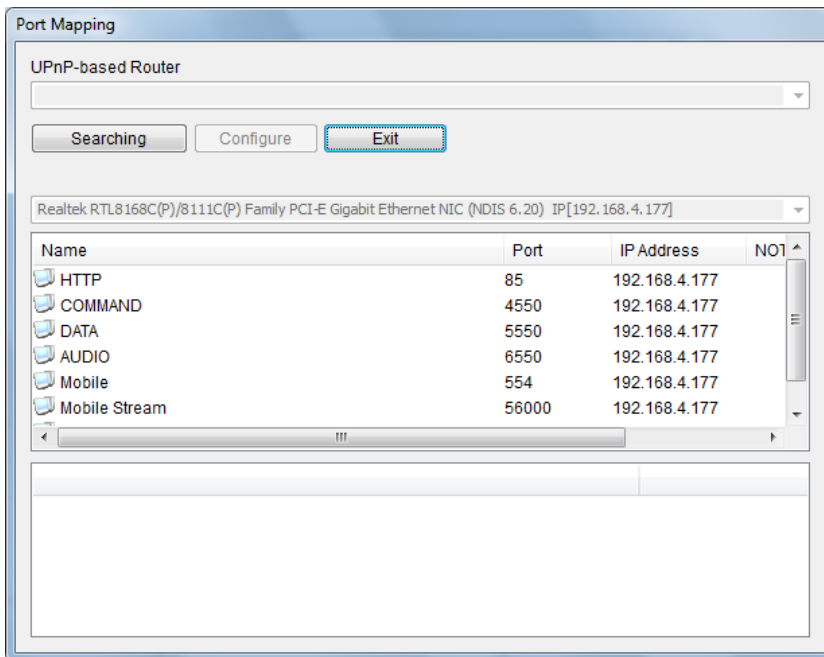

Figure 7-8

3. Click **Searching** to search the UPnP-enabled routers.
4. If your server is installed with multiple routers, select one from the UPnP Router drop-down list.
5. If your server is installed with multiple network adapters, select one from the drop-down list under the Searching button.
6. Click **Configure** to automatically configure the communication ports on the router.

Note: If you don't use the default ports, modify the related ports in the Server Setup dialog box (Figure 7-4) and then click **OK**. Re-open the dialog box and follow the above steps to configure your router.

7.2.7 Network Port Information

The Network Port Information is designed for users to view and manage all network ports of remote applications.

On the main screen, click **Home**  > **Toolbar**  > **Network**  > **Network Port Information**. This dialog box appears.

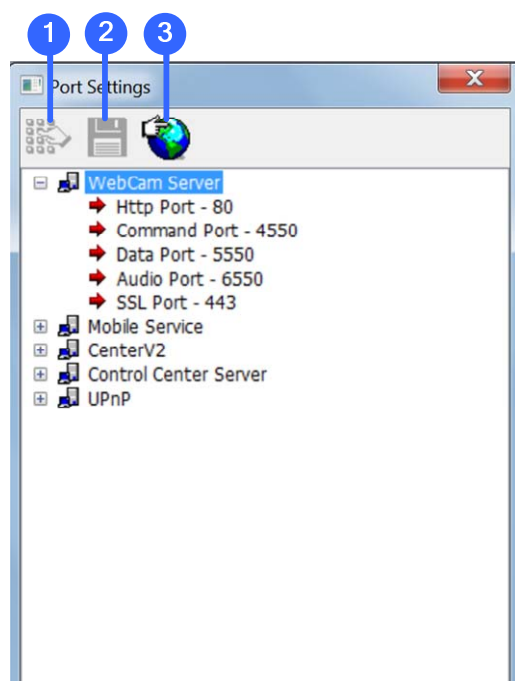

Figure 7-9

The controls on the Port Settings:



No.	Name	Description
1	Modify	Changes the port settings.
2	Save	Saves the port settings.
3	Port Mapping	Employs UPnP technology (Universal Plug and Play) to allow automatic port configuration to the router.

7.2.8 Mobile Service

Mobile Service allows remote connection and video streaming from GV-VMS by other applications, namely GV-Eye, GV-Edge Recording Manager – Mac version and the multicast of GV-Control Center. You can also optionally add additional security protection for live streaming between GV-VMS and the connected applications by enabling AES Encryption.

For details on configuring multicast on GV-Control Center, see *Multicast Setting*, Chapter 9, in *GV-Control Center User's Manual*.

To add AES Encryption:

1. After connecting to GV-Edge Recording Manager / GV-Control Center / GV-Eye, on the main screen of the GV-VMS host, click **Home**  > **Toolbar**  > **Network**  > **Mobile Service**.
2. Select **Enable AES Encryption**.

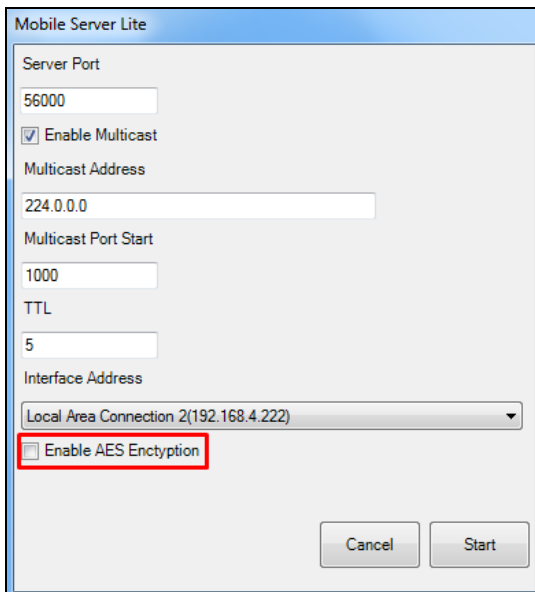

Figure 7-10

Note: The function of enabling AES Encryption is only compatible with

- GV-Edge Recording Manager V1.3.0.0 or later
 - GV-Control Center V3.5.0.0 or later
 - GV-Eye V2.5 or later
 - WebCam Server V17.1 or later
-

7.3 Single View Viewer

After logging into the WebCam Server successfully, you can see the single live view from the GV-VMS.

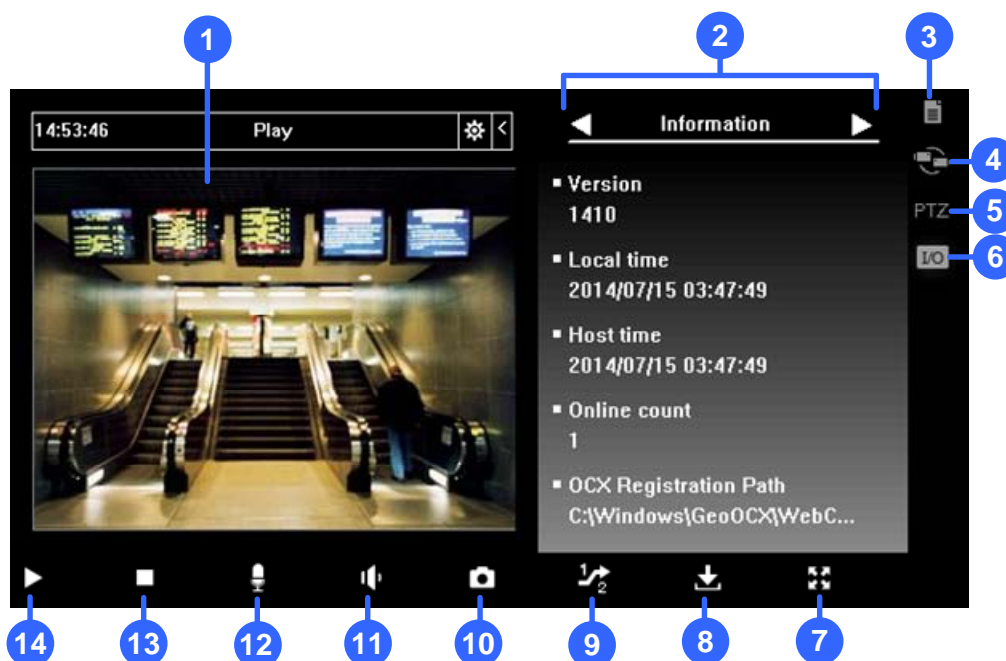

Figure 7-11

The controls in the Single View Viewer:

No.	Name	Description
1	Live Video	Right-clicking on live video allows you to instantly access some useful functions. The Resolution option can display a resolution indicator at the bottom right corner of the video.
2	Control Panel	See <i>Control Panel</i> later in this chapter.
3	Options	See <i>Alarm Notification</i> , <i>Video and Audio Configuration</i> , <i>Server List</i> , <i>Show Camera Name</i> and <i>Image Enhancement</i> later in this chapter.
4	Change Camera	Selects the desired camera for display.
5	PTZ Control	See <i>PTZ Control</i> and <i>Visual PTZ Control Panel</i> later in this chapter.
6	I/O Control	See <i>I/O Control</i> later in this chapter.
7	Full Screen	Switches to full screen view. The maximum video resolution configured on the WebCam Server will be applied. See <i>Video Settings</i> in <i>WebCam Server Settings</i> earlier in this chapter.
8	File Save	Saves video to a local computer in AVI format.

9	Change Quality	See <i>Adjusting Video Quality</i> later in this chapter.
10	Snapshot	Takes a snapshot of the displayed live video.
11	Speaker	See <i>Video and Audio Configuration</i> later in this chapter.
12	Microphone	See <i>Video and Audio Configuration</i> later in this chapter.
13	Stop	Terminates the connection to the remote GV-VMS.
14	Play	Connects to the remote GV-VMS.



Displaying Full-Screen Live View on Other Monitors

Using the IE browser, you can display up to 10 full-screen channels with multiple monitors installed. Right-click the live view and select a designated monitor to bring full-screen live view. The full-screen live view appears on the designated monitor immediately.

Note: The full-screen display closes at the designed monitor if its Web interface window is minimized.

7.3.1 Adjusting Video Quality

To adjust the live view quality to have megapixel resolution in the Single View Viewer:

1. Select **Actual Size** on the GV-VMS. Click **Home**  > **Toolbar**  > **Network**  > **WebCam Server** > the **Video** tab > select **Actual Size** in the Max. Image Size option.

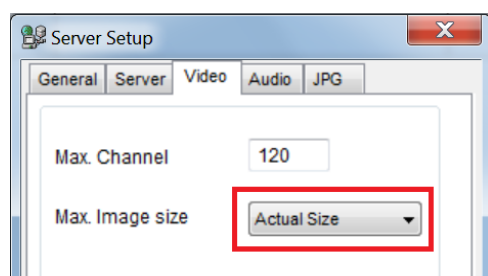

Figure 7-12

2. On the Single View, click the **Change Quality** button (No. 9, Figure 7-11). You will have the option of megapixel resolution now.

Note:

1. Streaming live view in Actual Size requires a lot of bandwidth. It is highly recommended to enable this function in a LAN environment.
 2. To have fisheye dewarping view, you must first follow the steps above to set fisheye camera to megapixel resolution. Next, right-click the camera view and select **Geo Fisheye**. For details on the fisheye settings, see *Fisheye View* in chapter 3.
-

7.3.2 Control Panel

A control panel can be opened next to the live view by clicking the **Menu** button and selecting any of the options. To change the pages of the control panel, use the right and left arrow buttons on the panel, or click the **Menu** button to directly make selection.

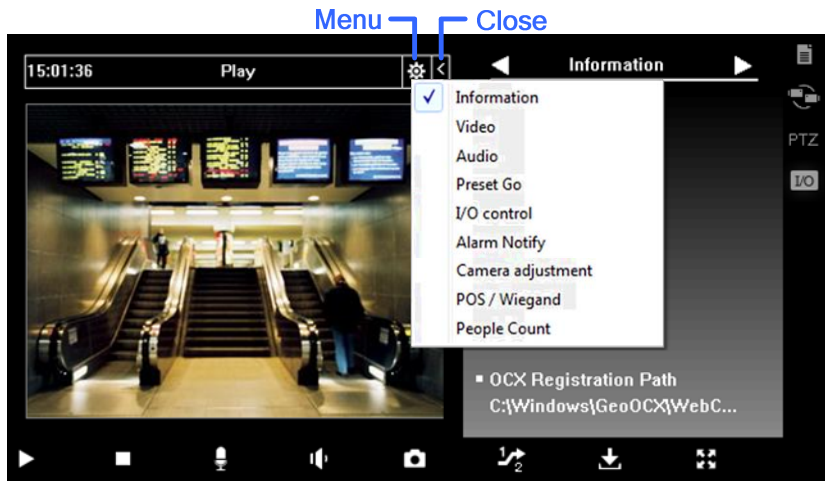

Figure 7-13

Name	Description
Information	Displays the current version, local time, host time and number of channels currently accessing WebCam.
Video	Displays the current video codec, resolution and data rate.
Audio	Displays audio data rates when the microphone and speaker devices are enabled.
Preset Go	Allows you to remotely move the PTZ to the preset points.
I/O Control	Provides a graphic display of the input and output devices from the GV-VMS.
Alarm Notify	Displays the captured images by sensor triggers and/or motion detection. See <i>Alarm Notification</i> later.
Camera Adjustment	Remotely adjusts image quality by moving the slider to the desired values.
POS/Wiegand	Not functional.
People Count	Views the counts of Object Counting along with live view. Once the counts are logged into the GV-VMS, In and Out counts will become zero and the system will start counting those numbers again.

7.3.3 Configuring Single View Viewer Options

To access the Single View Viewer options, click the **Option** button located on the right of the live view.

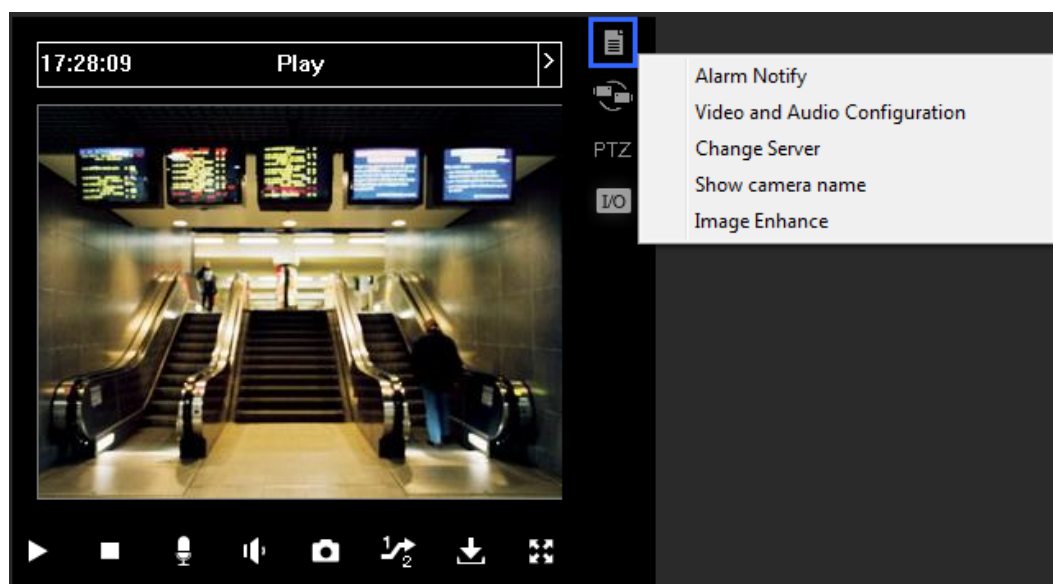

Figure 7-14

Alarm Notification

Up to four captured images can be shown in the control panel upon motion detection or input trigger.



Figure 7-15

1. Click the **Option** button, and select **Alarm Notify**. The Alarm Notify dialog box appears.
 - **Motion Notify**: The captured images are displayed in the control panel of the Single View upon motion detection.
 - **I/O Alarm Notify**: The captured images are displayed in the control panel of the Single View upon input-triggered detection.

- **Alert Sound:** Activates the computer noise alarm on motion and input-triggered detection.
- **Auto Snapshot:** The program will take a snapshot every 5 seconds on motion and input-triggered detection.
- **File Path:** Assigns a path to save the snapshots.

2. Click **OK** to apply the above settings.

Video and Audio Configuration

To change the video and audio configurations of the connected camera, click the **Option** button, and select **Video and Audio Configuration**.

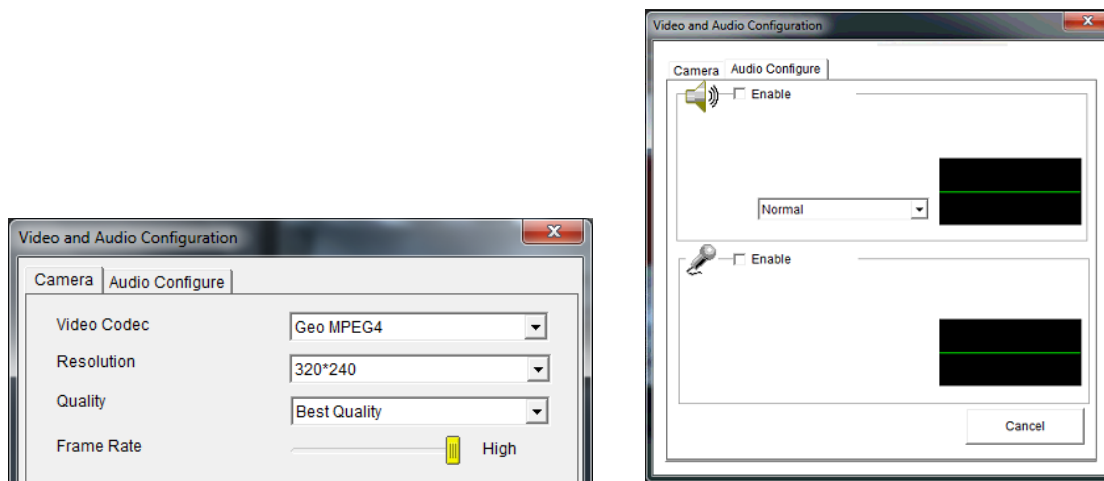

Figure 7-16

[Camera] Change the video codec, quality and frame rate. The resolution options depend on the maximum image size set on the connected GV-VMS. For details, see *Video Settings* in *WebCam Server Settings* earlier in this chapter.

[Audio Configure] Enable the microphone and speaker for two-way audio communication. Select **Speaker** to access live audio from the server site, and select **Microphone** to speak to the server site. Ensure the speaker and microphone are properly installed in the local computer, and the audio settings (Figure 7-6) are activated on the WebCam Server too. There are three options for audio quality:

- **Real Time:** Transmits simultaneously audio and video but may create sound interruption, depending on your network condition.
- **Smooth:** Has a smooth sound quality but without audio and video synchronization.
- **Normal:** The default value which has the audio and video effects between Real-Time and Smooth.

Server List

You can add the connection information of multiple GV-VMS to the WebCam Server for quick access later. Click the **Option** button, and select **Change Server** to display the following dialog box.

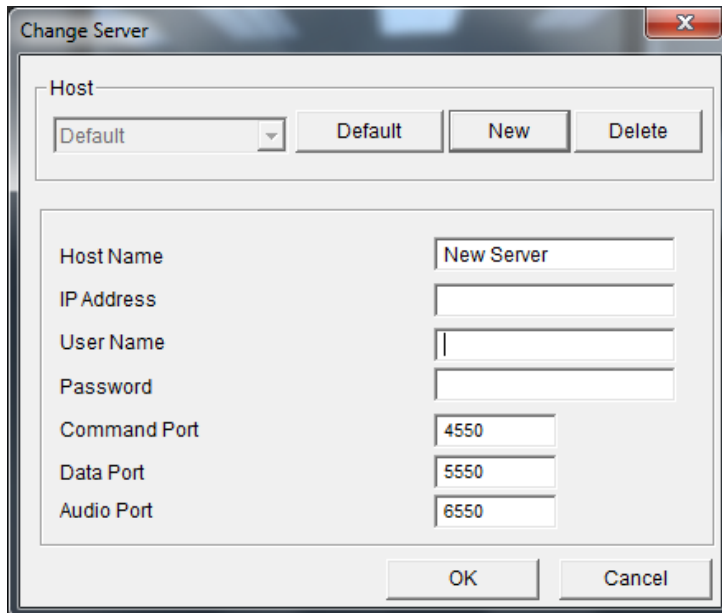

Figure 7-17

To add a server to the drop-down list, click the **New** button. In Host Name field, type a name to identify the GV-VMS. Type the IP address or domain name of the GV-VMS. Type a valid username and password to log onto the GV-VMS. Leave all port settings as defaults at **4550**, **5550**, and **6550** respectively unless otherwise necessary. Click the **OK** button. Then the created GV-VMS will appear in the Host drop-down list.

Show Camera Name

To show camera name on top-left corner of the live view, click the **Option** button and select **Show Camera Name**.

Image Enhancement

To enhance the image quality of live video, click the **Option** button and select **Image Enhance**.

- **De-Interlace:** Converts the interlaced video into non-interlaced video.
- **De-Block:** Removes the block-like artifacts from low-quality and highly compressed video.
- **Enable DirectDraw:** Enabled by default. Some VGA cards might not support DirectDraw and can produce distorted frames. Clear this option to disable the DirectDraw function.

7.3.4 PTZ Control Panel

Click the **Camera Select** button to select one PTZ camera, and click the **PTZ Control** button (No. 7, Figure 7-14) to bring up the PTZ control panel.

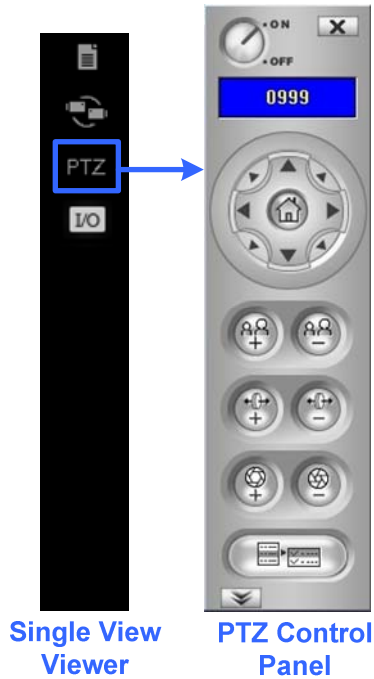



Figure 7-18

One PTZ camera can only be controlled by one user at a time. If several users are trying to control the same PTZ camera at the same time, the Single View viewer will give the priority to the first logon user and then to the next user in queue.

Each user will be given 60 seconds to control the PTZ camera. The Timer at the upper right corner informs the user of the remaining time of control or the total waiting time. The supervisor is given 666 seconds, which the highest priority to control the PTZ camera.

Click the  button to access additional PTZ functions. The functions available vary, depending on the PTZ models.

7.3.5 Visual PTZ Control

Other than the PTZ control panel, you can enable the Visual PTZ Control functions. Right-click the live view and select **Visual PTZ**. Next, click the green **PTZ** button on the top left corner of the PTZ control window to have these options:

- **Random Move:** You can move the camera view to any direction by clicking on a desired direction. When you place the mouse cursor on the live view, a circular PTZ control panel appears. See *PTZ Control Panel and Auto Functions* in Chapter 1 for details on the circular PTZ control panel.

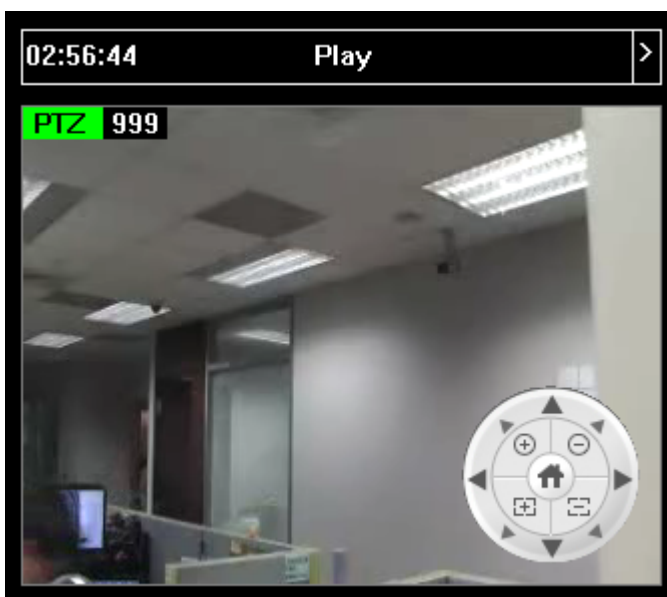
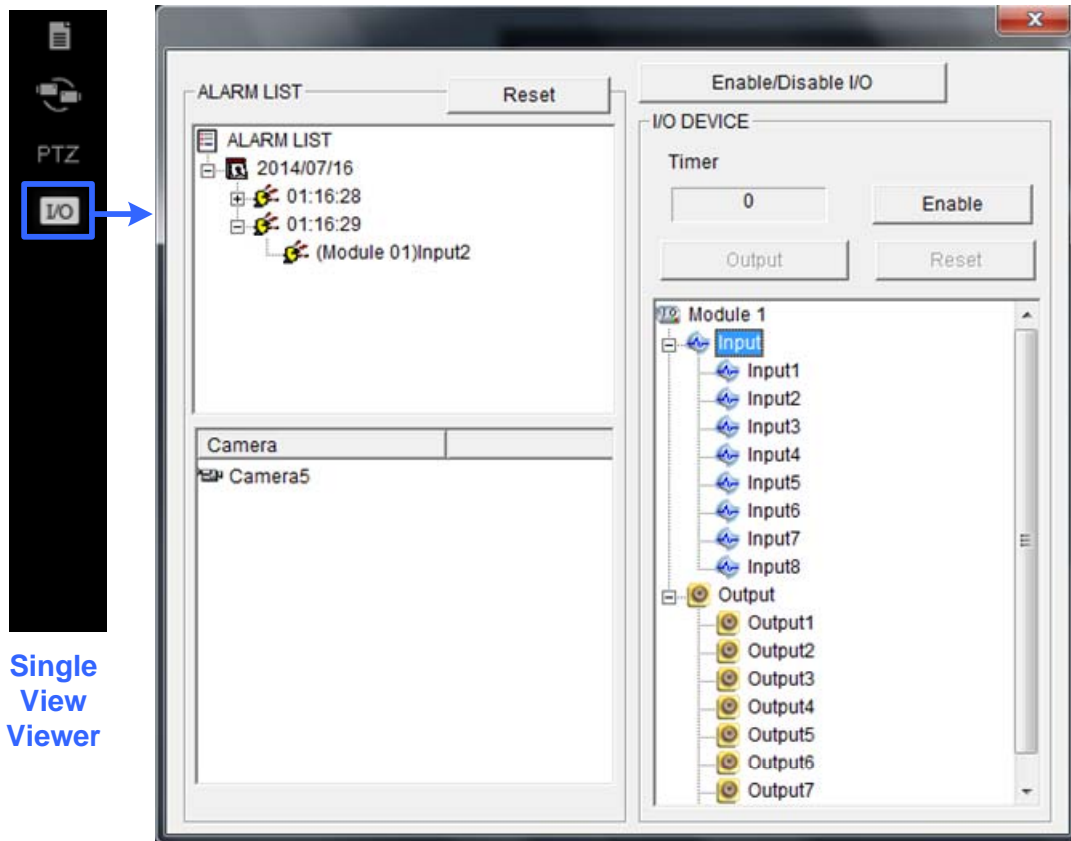

Figure 7-19

- **Center Move:** Only for GV-SD220, you can zoom in and out using the mouse scroll or by drawing a block directly on the live view.

7.3.6 I/O Control

The I/O control panel shows the I/O status and alarm event. Additionally, you can force output, as well as enable and disable I/O devices to the remote GV-VMS. Click the **I/O Control** button at the right of the live view to bring out the I/O control panel.



I/O Control Panel

Figure 7-20

The alarm status shows the triggered inputs. Clicking the **Reset** button will clear the alarm list.

To force to trigger an output device, click the **Enable** button, highlight an output and then click the **Output** button. The Timer functions the same as in the PTZ control panel. Each user will be given 60 seconds of control time while the supervisor has 999 seconds. Clicking the **Stop** button will stop the operation and turn over the control privilege to the next user waiting online.

If you want to enable or disable I/O devices to the remote GV-VMS, click the **Enable/Disable I/O** button. Note that the **Enable Remote Control** option must be enabled in the WebCam Server Setup dialog box (Figure 7-4)

7.3.7 Visual Automation

If the Visual Automation function is enabled on the GV-VMS, you can remotely trigger the connected output by simply clicking on a designated spot on the live view. For details on setting up Visual Automation, see *Visual Automation* in Chapter 6.

1. To access this feature, right-click the live view and select **Visual Automation**. A green I/O icon appears in the corner.
2. To see where the designated visual automation spots are located, right-click the live view again, select **Visual Automation** and select **Show All**.
3. Click the alert areas on the image to force the outputs to be triggered remotely.

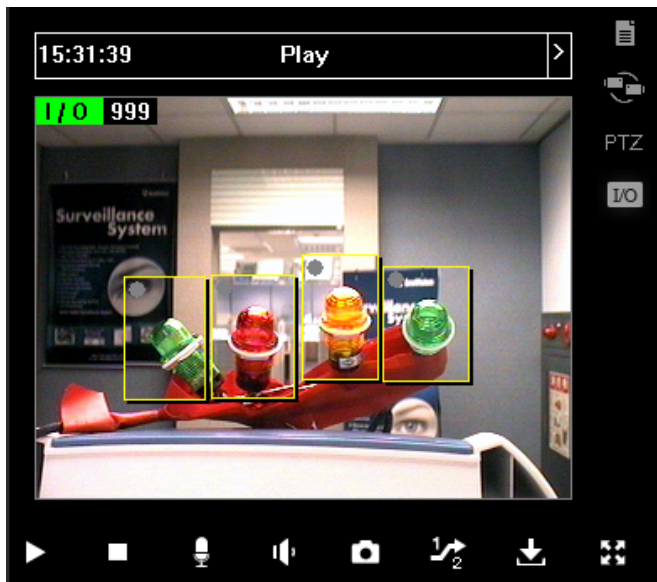

Figure 7-2

7.3.8 Picture-in-Picture View

With the Picture in Picture (PIP) view, you can crop the video to get a close-up view or zoom in on the video. This function is useful in providing clear and detailed images of the surveillance area.

1. Right-click on the screen and select **PIP**. An inset window of the camera view appears in the live view.



Figure 7-22

2. Move the navigation box around in the inset window to have a close-up view of the selected area. You can adjust the size of the navigation box if needed.
3. Drag the inset window to adjust its location on the live view if needed.
4. To exit the PIP view, click the camera name and click **PIP View** again.

7.3.9 Picture-and-Picture View

With the Picture and Picture (PAP) view, you can create a split video effect with multiple close-up views on the image. A total of 7 close-up views can be defined. This function is useful for megapixel resolution that provides clear and detailed images of the surveillance area.

1. Right-click on the live view and select **PAP**. A row of three inset windows appears on the bottom of the screen.
2. Draw a navigation box on the image, and this selected area is displayed in one inset window. Up to seven navigation boxes can be drawn on the image. You can adjust the size and the location of the navigation box if needed.



Figure 7-23

3. To exit the PAP view, right-click the live view and select **PAP** again.

7.4 Multi-Window Viewer

The Multi Windows displays up to 16 channels at a time and supports up to 64 channels.

To access the Multi Windows, click **Live View** on the left panel of the Webcam Viewer page, and select **Multi Windows**.

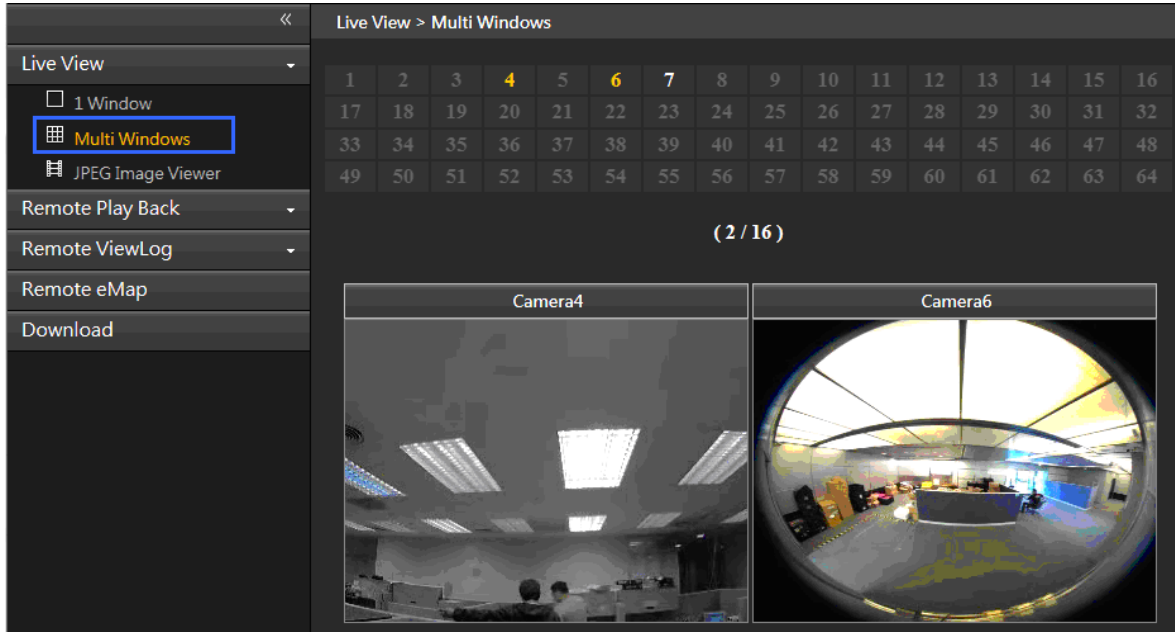





Figure 7-24

7.5 JPEG Image Viewer

JPEG Image Viewer is a cross-platform viewer, compatible with Mac OS and Microsoft IE browsers. Continuously receiving JPEG images from the GV-VMS and limited to the single camera view, the viewer is an ideal tool for the users with limited Internet bandwidth.

Note: To enable the JPEG Image Viewer, Java needs to be installed on the local PC.

To enable the viewer:

1. Click **Home**  > **Toolbar**  > **Network**  > **WebCam Server**.
2. Disable **Enhance Network Security** under the General tab (Figure 7-4), and enable **Create JPEG/GIF File(s)** under the JPG tab (Figure 7-7).
3. Access the GV-VMS using a Web browser.
4. On the left panel of Singe View page, click **Live View** and select **JPEG Image Viewer**. The JPEG Image Viewer appears.

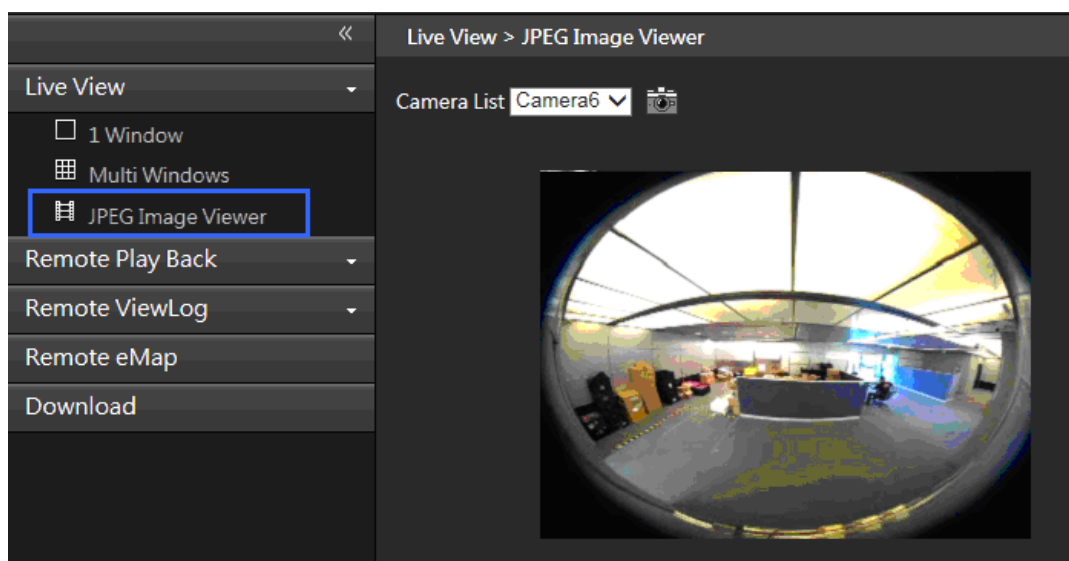

Figure 7-25

7.6 Playing Back Events

7.6.1 Event List Query

The Event List Query function on the WebCam Server allows you to remotely search for an event by defining event type and time. The search results can be displayed in text form or in a chart. You can also play back events instantly from the search results.

To allow remote access to GV-VMS and remotely play back events,

- Ensure the WebCam Server with the **Run ViewLog Server** function (Figure 7-3) is activated on GV-VMS.
- Ensure that the **Register Event** options are selected under the events you want to access. For example, the Register Motion Event option needs to be selected to access motion events.

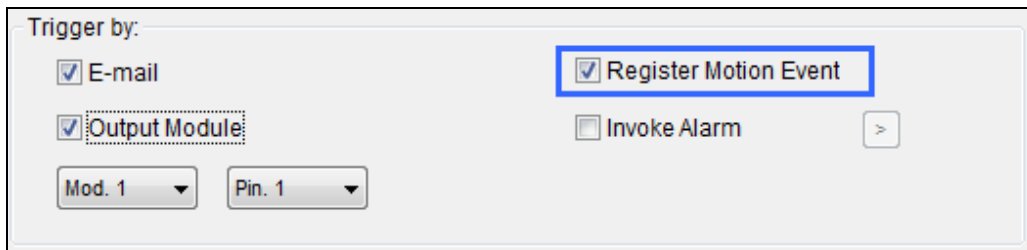

Trigger by:

E-mail

Output Module

Register Motion Event

Invoke Alarm

Mod. 1 Pin. 1

Figure 7-26

1. On the left panel of the Single View page, click **Remote Play Back** and select **Event List Query**. The Query window appears.
2. On the top, select one of the following search categories: **Monitor, System, Login, Counter, Merge, Backup** and **Delete**. Note that the above categories are based on those of System Log in the Main System, so you can also locate the same event recorded in System Log.
3. Define the search criteria such as Event Type, Device, Information, Date and etc. The selection of search criteria may vary, depending on search categories.

4. Click **Submit Query**. The search results will be displayed in the text form.

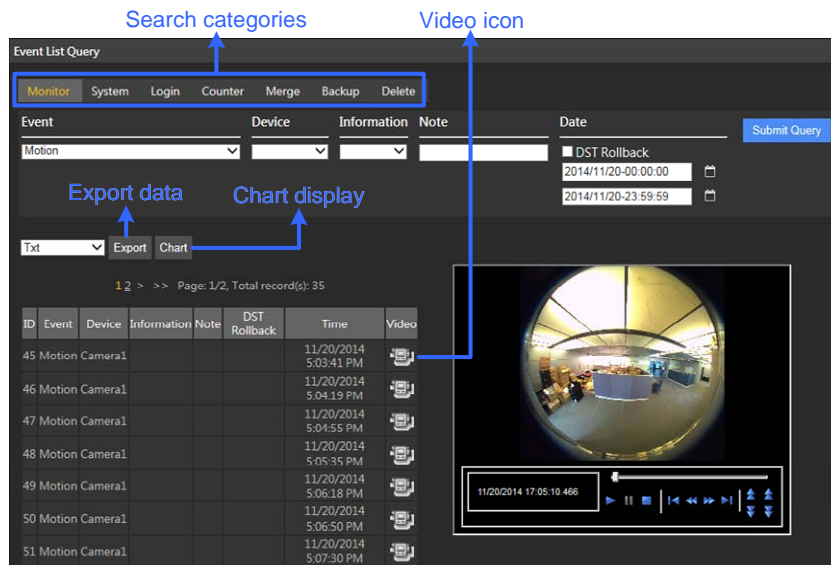

Figure 7-27

5. To play back the attached video, click the **Video** icon. For more playback features, right-click on the video image.
6. To graph the search results, click the **Chart** button.
7. To export the search results, select one of the formats and click the **Export** button.

7.6.2 Remote Playback

With the Remote Playback (RPB) function on the WebCam Server, you can play back the recorded files of the connected GV-VMS.

1. To allow remote access to GV-VMS, ensure the WebCam Server with the **Run ViewLog Server** function (Figure 7-3) is activated on GV-VMS.
2. On the left panel of the Single View page, click **Remote Play Back** and select **Remote Play Back**. The Remote Play Back appears.
3. Select the desired camera, date and time-segment file.
4. Click the **Play** button to start.
5. For additional playback features, right-click on the image to have the options of **Play Mode**, **Render** and **Tools**.

7.7 Remote ViewLog

Through WebCam Server, you can remotely play back the recorded files by using the ViewLog player.

1. To allow remote access to GV-VMS, ensure the WebCam Server with the **Run ViewLog Server** function (Figure 7-3) is activated on GV-VMS.
2. On the left panel of the Single View page, click **Remote ViewLog**. Remote ViewLog will be installed on your PC if it is not already.

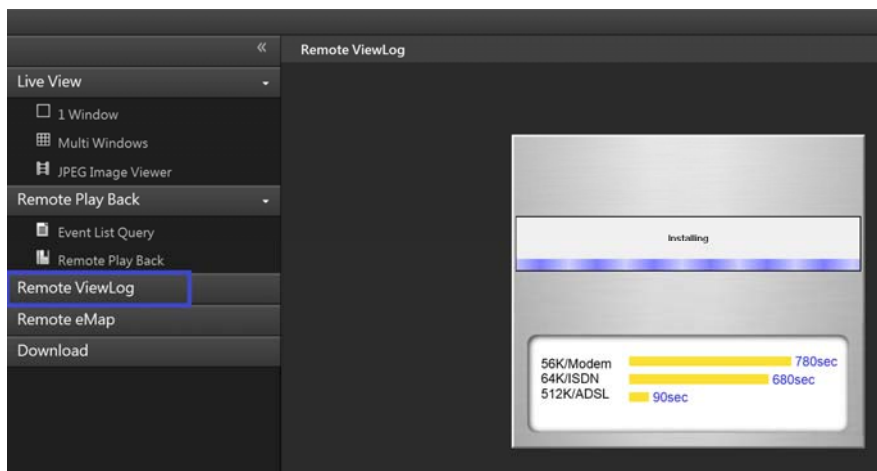

Figure 7-28

3. Execute GV-Remote ViewLog and create a Remote ViewLog account on the Add Remote Viewlog Account dialog box.
4. After creating an account, the Add New Host dialog box appears.
5. In the Host Type, select **DVR / NVR / VMS**. Type the **Location Name**, **IP Address**, **Account** and **Password** of the GV-VMS. Only modify the default port 5552 if necessary.
6. Click **OK**. The events available will be listed in the Event List.

For details on ViewLog player functions, see Chapter 4.

7.8 Download Center

The Download Center allows you to download Remote ViewLog, Remote eMap and GV-Edge Recording Manager.

1. Click **Download** in the left panel of the Single View page. This page appears.

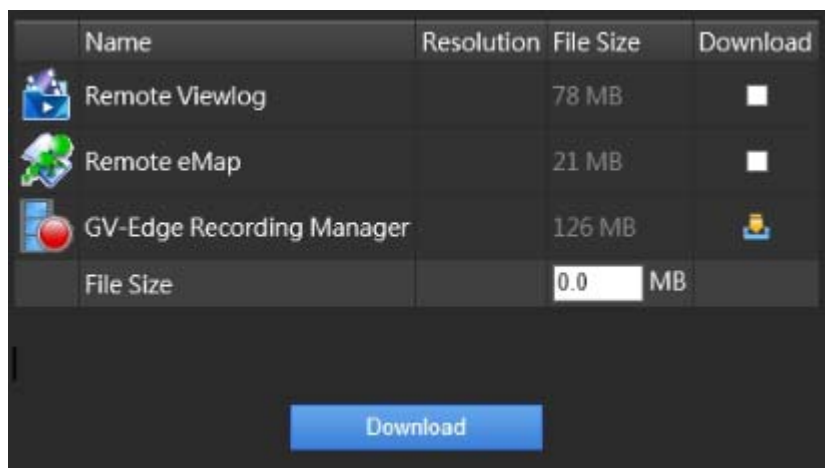

Figure 7-29

2. Check the desired programs. The **File Size** field will display the total file size of the selected programs.
3. Click **Download** and follow the on-screen instructions to install the programs. When the installation is complete, the message "*Install Complete*" will be displayed.

7.9 GV-Edge Recording Manager

GV-Edge Recording Manager is a remote viewer for live view display and video playback from GV-IP cameras and the video channels connected to GV-Video Server, GV-VMS, GV-System, GV-Recording Server and GV-SNVR.

For details on GV-Edge Recording Manager, please visit our website:

- [GV-Edge Recording Manager \(Windows Version\)](#)
- [GV-Edge Recording Manager \(MAC Version\)](#)
- **GV-Edge Recording Manager (Windows Version):** Make sure that **Control Center Service** and **Remote ViewLog Service** are enabled on GV-VMS.
- **GV-Edge Recording Manager (MAC Version):** Make sure that **Webcam Server** and **Mobile Service** are enabled on GV-VMS.

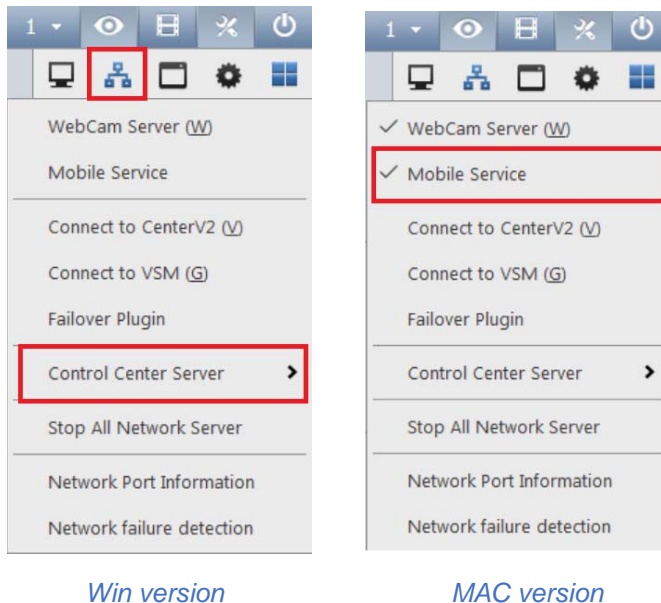

Figure 7-30

Note:

1. **Mobile Service** has the exact function as that of **Run Mobile Service** (WebCam Server > General Tab).
 2. To optionally add additional security protection of the live streaming between GV-VMS and GV-Edge Recording Manager through AES encryption, see *Mobile Service* earlier in this chapter.
-

7.10 Mobile Phone Applications

With a smartphone, you can receive live videos from GV-VMS using mobile app GV-Eye. The GV-Eye can be downloaded from App Store or Android Market.

For details on accessing live view, playing back recording and other functions, refer to [GV-Eye Installation Guide](#)

7.11 Web Browsers on Smartphones

Using the browser on your smartphone, you can watch live view, control PTZ live views, and play back recordings from a GV-VMS. By connecting to the WebCam Server, no extra application is required.

Note:

1. Make sure the Mobile function is enabled on the WebCam Server.
 2. Live view control is only available for supported PTZ cameras.
-

In the following steps, we use the Android smartphone as an example to log onto the GV-VMS:

1. Open the browser on your Android device and type the IP address of the GV-VMS to log on.

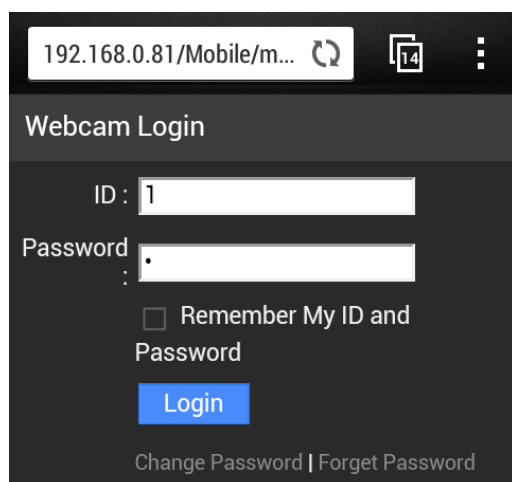

Figure 7-31

2. Click **Login**. The cameras on the GV-VMS appear.

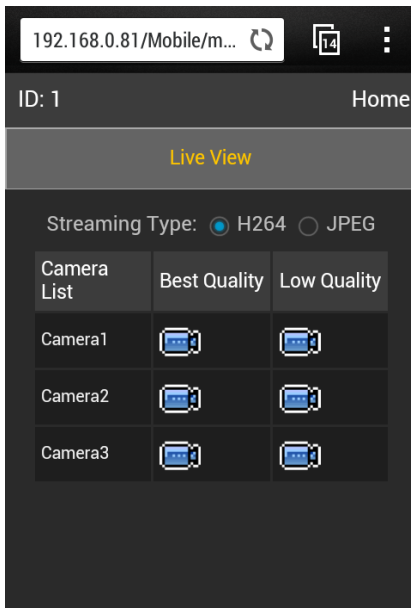



Figure 7-32

3. To watch live view, keep **H.264** as **Streaming Type**, and tap a **video** icon . Stream 1 will be displayed when Best Quality is selected and Stream 2 will be displayed when Low Quality is selected.
4. To access the PTZ functions, tap **JPEG** as **Streaming Type**. This page appears. You can control the live view with the direction arrows, zoom in/out and home position buttons.

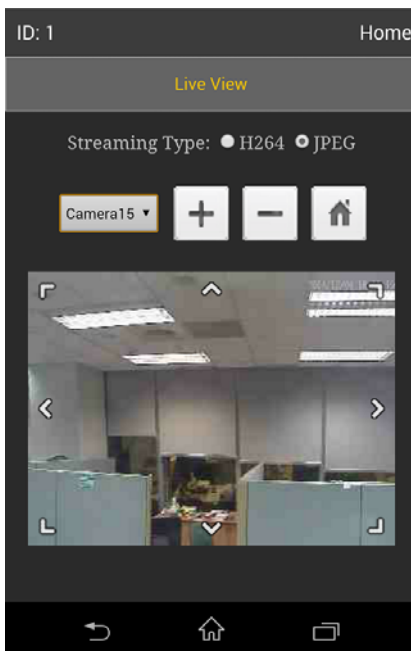

Figure 7-33

Chapter 8

E-Map Application.....	260
8.1 The E-Map Editor.....	260
8.1.1 The E-Map Editor Window	261
8.1.2 Creating an E-Map.....	262
8.1.3 Creating an E-Map for a Remote Host.....	265
8.2 Starting E-Map	266
8.2.1 Setting up the Pop-up Map	267
8.3 3D E-Map Display	268
8.3.1 3D E-Map Display.....	268
8.3.2 Utilizing the 3D E-Map Icons	269
8.4 Remotely Accessing E-Map	270
8.4.1 The Remote E-Map Window	271
8.4.2 Accessing E-Maps of Multiple Hosts	272
8.4.3 Configuring the Remote E-Map.....	273
8.4.4 Viewing Event List and Playing back Videos	275
8.5 E-Map Server	275
8.5.1 Installing E-Map Server	275
8.5.2 The E-Map Server Window	276
8.5.3 Setting up E-Map Server	277
8.5.4 Connecting to E-Map Server	277

E-Map Application

The E-Map displays the monitoring area on an electronic map, by which the operator can easily locate the cameras, sensors and alarms triggered by motion or I/O devices.

The application is available through two programs: **E-Map Editor** which comes with the installation of GV-VMS, and **E-Map Server** applicable on a designed server.

8.1 The E-Map Editor

The E-Map Editor allows you to import a floor plan in BMP, GIF or JPEG formats, and use the icons of cameras and I/O devices to customize a map.

8.1.1 The E-Map Editor Window

The E-Map Editor comes with the installation of GV-VMS. Click the Windows **Start** menu, find **Programs**, select **GV folder** and click **E-Map Editor**. The E-Map Editor window appears.

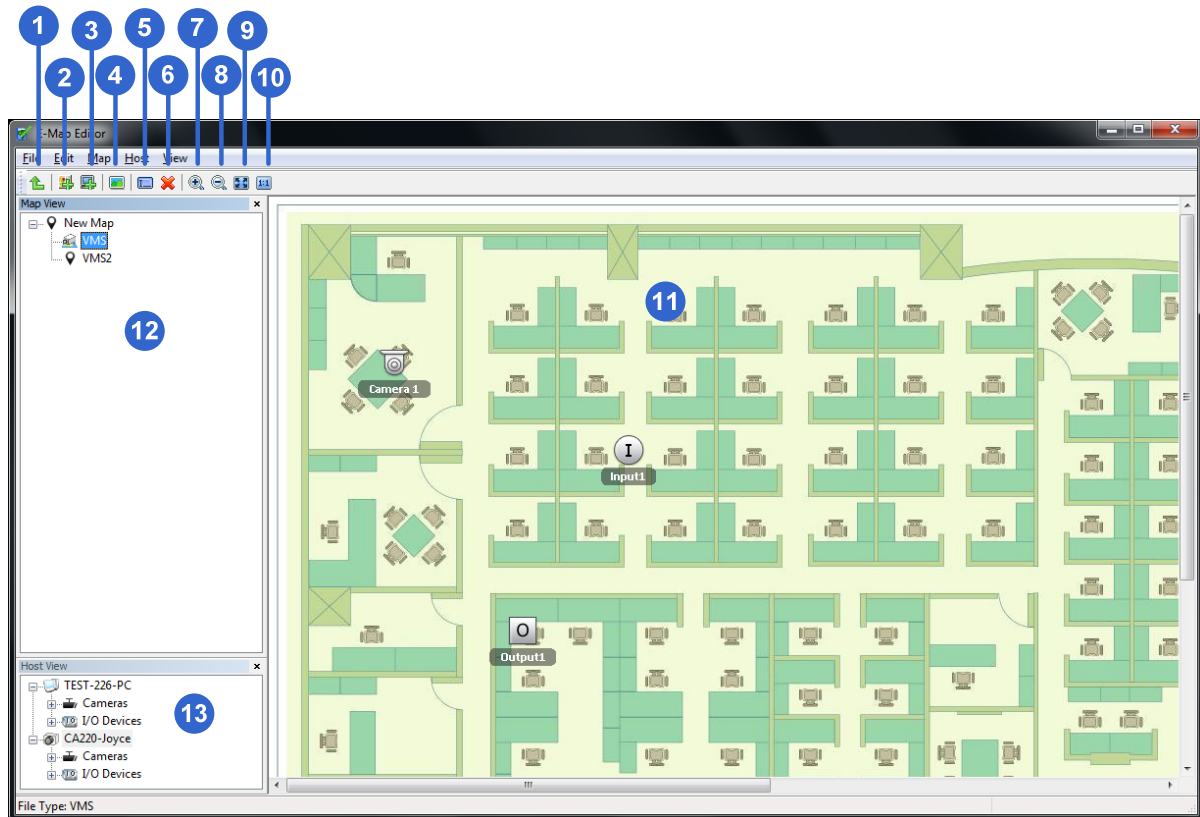



Figure 8-1

The controls in the E-Map Editor window:

No.	Name	Description
1	Up	Returns to the previous E-Map file.
2	Add Map	Adds an E-Map file.
3	Add Host	Adds a host folder in the Host View.
4	Load Map	Imports a floor map.
5	Rename	Renames an E-Map file and/or folder.
6	Delete	Deletes an E-Map file and/or folder.

No.	Name	Description
7 & 8	Zoom In / Out	Enlarges / Diminishes the Map View.
9	Fit to Screen	Adjusts the Map View to fit the current size of the window.
10	Actual Size	Displays the actual size of the imported graphic file.
11	Floor Plan	The view of imported graphic file.
12	Map View	Tree view of E-Map files.
13	Host View	Tree view of hosts

8.1.2 Creating an E-Map

1. To create an E-Map, click **Add Map**  on the toolbar. A New Map file is created.
2. Right-click **New Map** under Map View and select **Load Map** to import a graphic file. The file opens in the Floor Plan window (No. 11, Figure 8-1).

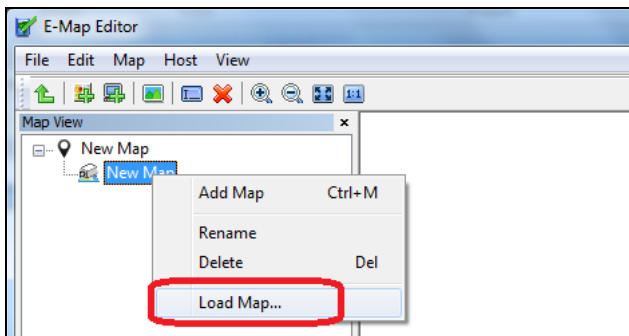

Figure 8-2

3. Double-click the local server folder in Host View (No. 13, Figure 8-1). The program automatically detects all of the cameras and I/O devices installed on the server and display their icons.

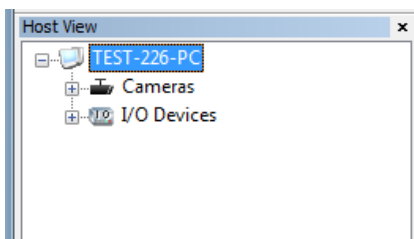

Figure 8-3

4. Drag and drop these icons from Host View to the map in the Floor Plan window.
5. Click **File** in the window menu and select **Save to VMS** to save the file to the GV-VMS folder, or select **Save to File** to save the file to a desired path.

Advanced Settings

Optionally, you can have the following settings on your created E-Map.

Note: The changes in the orientation of camera icons will not be reflected on the 3D E-Map.

A. Camera Icons

1. To set the orientation of camera icons, right-click any camera icon and select a desired direction.

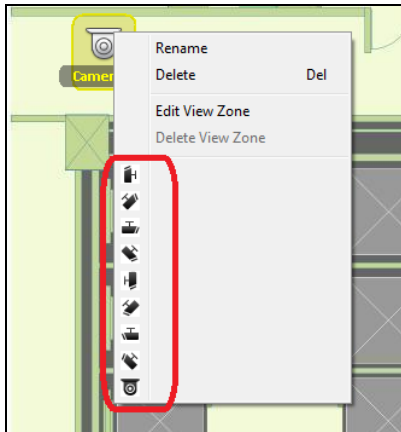

Figure 8-4

2. Optionally set up a view zone to highlight the area monitored by the camera:
 - A. Right-click any camera icon and select **Edit View Zone**. A fan-shaped view zone appears.

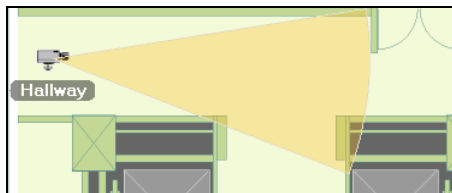

Figure 8-5

- B. Move the mouse to adjust the length and direction of the view zone.
- C. Scroll the mouse to adjust the width of the view zone.
- D. Right-click the map and select **Finish** to finalize the zone.

B. I/O and Camera Icons

Optionally change the icons of any cameras and/or I/O devices by right-clicking on it and select **Change Icon**. This dialog box appears.

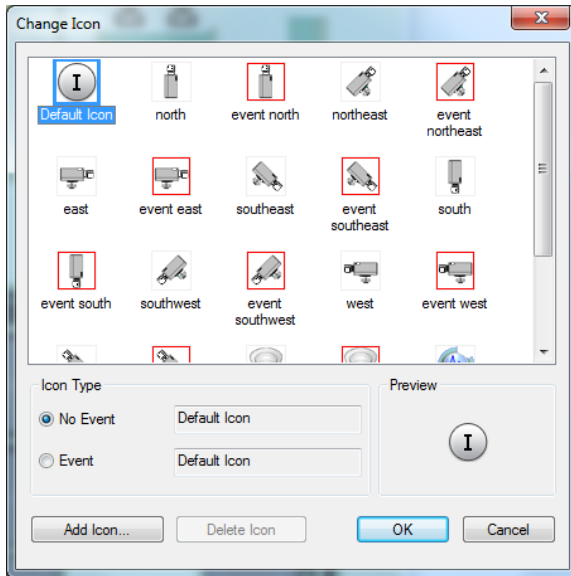

Figure 8-6

- **No Event:** Specifies the icon of the device when it hasn't been triggered. Optionally click **Add Icon** to import your own icon.
- **Event:** Specifies the icon of the device when it's been triggered. Optionally click **Add Icon** to import your own icon.

Note: The size of imported icon must be 32 x 32 pixels.

C. Polygonal Map

Optionally create a Polygonal Map within the E-Map, which flashes when any device within its region is triggered:

1. In E-Map, right-click the desired map icon and select **Edit Polygonal Map**.
2. Click on the map to draw a polygonal area with yellow dotted lines.

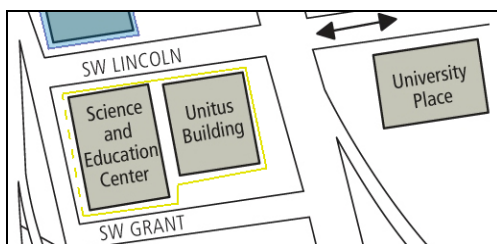

Figure 8-7

3. Once finished, right-click on the map and select **Finish**.

The enclosed area is colored in blue. When any device within the area is triggered, it will flash red.

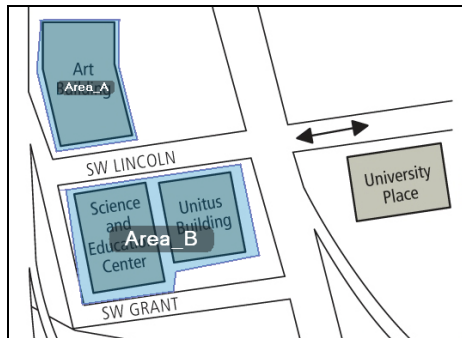



Figure 8-8

8.1.3 Creating an E-Map for a Remote Host

Aside from for the local host (GV-VMS), E-Maps can also be created for remote host(s). Through the Remote E-Map function, these E-Maps can be accessed and monitored through a Web browser. For how to remotely access E-Maps, see *Accessing E-Maps of Multiple Hosts* later in this chapter.

Note: The supported hosts for E-Map include GV-DVR / NVR / VMS, GV-IP Devices, GV-Video Server and GV-Compact DVR.

1. Click **Add Host**  on the toolbar and select the type of host. A new host is added in Host View.
2. Right-click the created host and select **Host Settings**. This dialog box appears, which varies depending on the host.

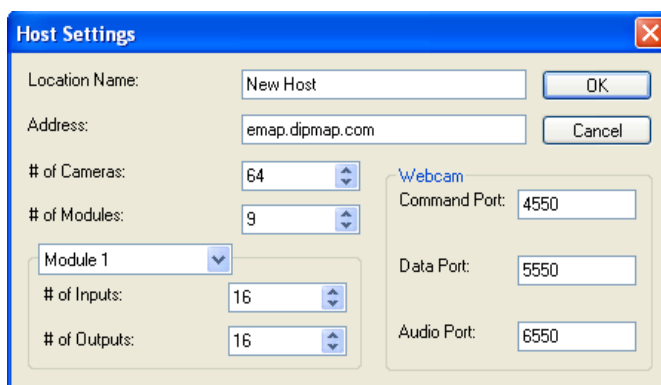

Figure 8-9

3. Type the necessary information, such as IP address and the number of cameras, and click **OK**.
4. Follow the instructions in *Creating an E-Map* earlier in this chapter to create an E-Map for the remote host.

8.2 Starting E-Map

After an E-Map is created, you can start the E-Map on GV-VMS and monitor through the E-Map. When any camera and/or I/O device on it is triggered, the corresponding icon will blink as an alert.

1. On the **Content List** of GV-VMS, expand the **E-Map** folder and drag the created E-Map to the live view grid. The E-Map is displayed.



Figure 8-10

2. When any camera or I/O device on the E-Map is triggered, its corresponding icon will blink red. Hover the cursor over the icon to see a live image of the event or click the icon to see the full view.

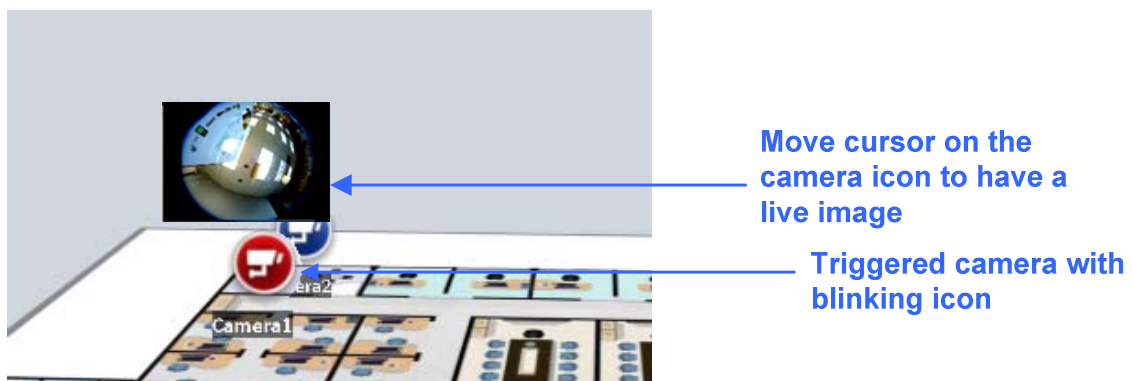

Figure 8-11

Note: If you have created the E-Maps for multiple hosts, you can also see these map files in the Content List. However, these map files won't function on the GV-VMS but only work on Remote WebCam through a Web browser. See *Accessing E-Maps of Multiple Hosts* later in this chapter.

8.2.1 Setting up the Pop-up Map

When multiple E-Maps are being monitored simultaneously, the pop-up function can be enabled for monitoring convenience. Once any camera or I/O device is triggered, its corresponding E-Map will pop up, replacing the current E-Map.

1. In the Content List, click the **Configure** button under E-Map.

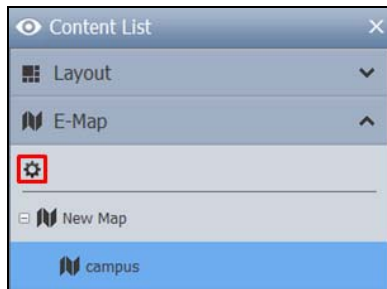



Figure 8-12

2. Select the desired cameras and input devices for the application, and specify **Interrupt Interval** for the duration between event triggers. Any event trigger will be ignored by the system during the interval to avoid frequent map pop-up.
3. At the bottom of the E-Map grid, click **E-Map Auto Pop-up**  to enable the function.

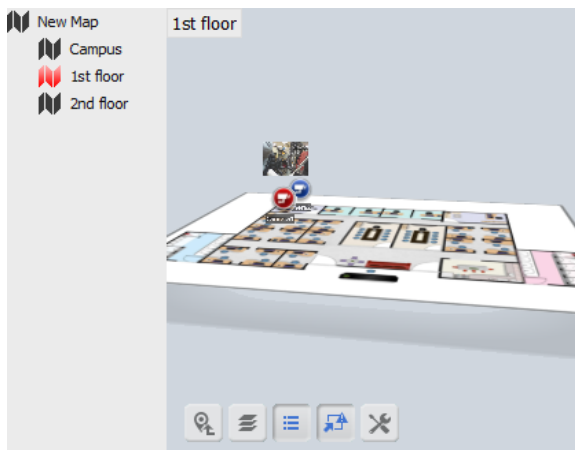

Figure 8-13

8.3 3D E-Map Display

Note the 3D E-Map function are only applicable to GV-VMS V16.10.3.0 or later.

8.3.1 3D E-Map Display

The E-Map can display the monitoring area in 3D view, meaning you can zoom in and out with the mouse wheel, and rotate the view as you wish.

1. Create an E-Map by following the instructions in *Creating an E-Map* earlier in this chapter. To build multiple layers of maps, create another subfolder under the E-Map folder, as illustrated below.

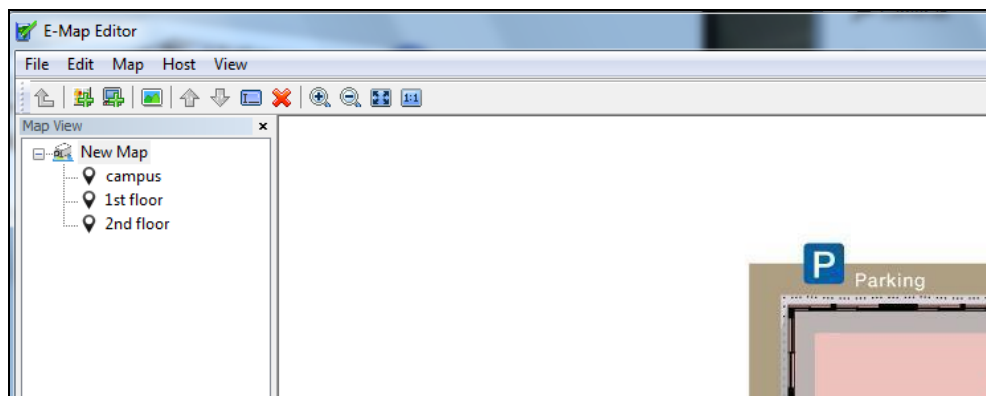

Figure 8-14





2. After creating an E-Map, click **Home > Toolbar > Content List** on GV-VMS.
3. Expand the **E-Map** folder and drag the created E-Map to the live view grid
4. To zoom in / out of the monitoring area, simply scroll the mouse wheel up or down.
5. To adjust the angle of view, click and hold on the E-Map and move in any direction as desired.
6. To move up or down the building view (No 2, Figure 8-15), right-click on the E-Map and scroll the wheel.

8.3.2 Utilizing the 3D E-Map Icons

The 3D E-Map display comes with a set of icons for settings and control. Place the mouse cursor on the E-Map to see the icons below.







Figure 8-15

No	Icons	Functions
1	Move Up 	Move to the main folder of the current E-Map.
2	Building View 	Switch the floor plan to 3D view mode of the building.
3	Map List 	Display the E-Map list.
4	E-Map Auto Popup 	Enable this function to automatically pop up the related map whenever any device on it is triggered. See <i>Setting Up the Pop-up Map</i> earlier in this chapter.

5	Tools 	<p>Includes the following options:</p> <ul style="list-style-type: none"> ■ Auto Rotate: Automatically rotates the E-Map anticlockwise. ■ Icon Options: <ul style="list-style-type: none"> ➤ Always Show Live Video: When selected, the received camera live view will always be displayed on the E-Map. ➤ Show Device Name: Display the device name on the E-Map. This option is enabled by default. ➤ Large Icons: Change to large icons of cameras. By default, the large icons are used. ➤ Small Icons: Enable this option if you want to use small icons. ■ Properties: Show the E-Map name on the upper-left corner and change the font size of the E-Map name. ■ Close: Remove the E-Map display.
---	---	---

8.4 Remotely Accessing E-Map

You can remotely access and view E-Maps with a Web browser.

1. To remotely access E-Maps through a Web browser, click **Home**  > **Toolbar**  > **Network**  > **WebCam Server** on GV-VMS. The Server Setup dialog box appears.
2. Click **OK** to start the WebCam server.
3. Open the Web browser and type the address of the GV-VMS. Once the connection is established, the Single View page appears.
4. On the left panel, click **Remote E-Map**. The Login dialog box appears.
5. Type the login info of the GV-VMS and click . The Remote E-Map window is displayed.

8.4.1 The Remote E-Map Window

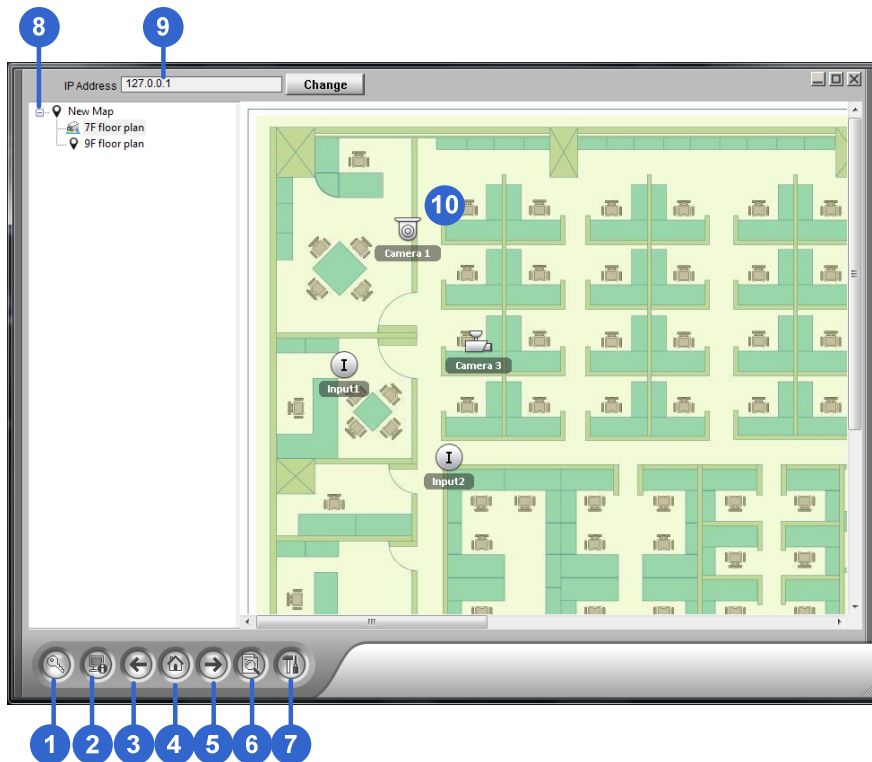

Figure 8-16

The controls in the window:

No.	Name	Description
1	Login	Logs up to 500 hosts.
2	Host Information	Views the information of incoming events upon motion detected and I/O devices triggered.
3	Previous	Goes to the last selected E-Map file.
4	Home	Goes back to the top of the tree view.
5	Next	Goes to the next E-Map file.
6	ViewLog	Accesses the Remote ViewLog function. For details, see <i>Remote ViewLog Service</i> in Chapter 4.
7	Configure	Configures the advanced settings.
8	Tree List	Displays all created E-Map files and folders.
9	IP Address	Displays the IP Address of the connected host. When events occur, the corresponding icons will blink red.
10	Camera / Input / Output Icon	Camera icon: Move the cursor over the icon to view a live image. Click the icon to open a control panel for the camera. Output Icon: Click the icon to manually trigger the output device. .

Note: By default, E-Maps opened with Remote E-Map are displayed in 3D. To display the E-Maps in 2D view, click the **Configure** button (No. 7, Figure 8-16) and select **Disable 3D eMap**.

The controls in the Camera Icon

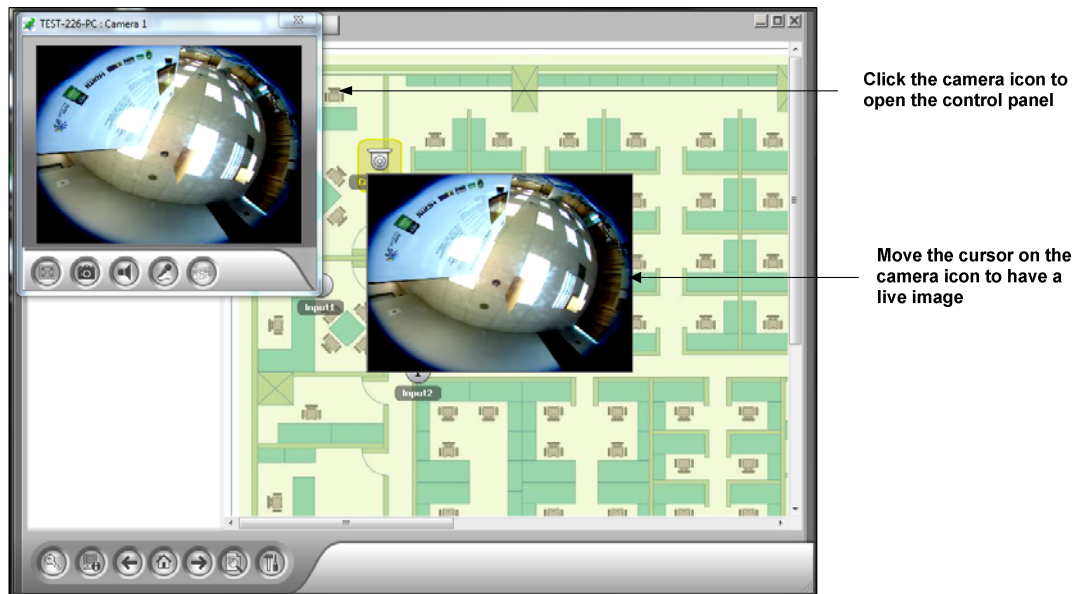



Figure 8-17

8.4.2 Accessing E-Maps of Multiple Hosts

If you have created E-Maps for multiple hosts, you can monitor these E-Maps remotely through a Web browser. Up to 500 hosts can be accessed at a time.

1. To start, click **Login**  on the Remote E-Map window. The Login window appears.

2. Select a host on the right panel and click **Login**. You are prompted for the required login info.

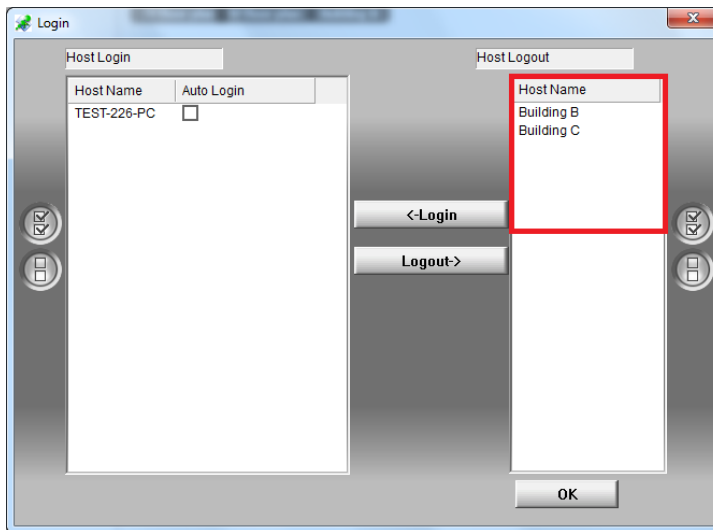



Figure 8-18

3. Click **OK** to return to the Remote E-Map window. Now you can select the corresponding E-Map for the new host for monitoring.

8.4.3 Configuring the Remote E-Map

Click **Configure**  on the Remote E-Map window. The Configure window appears.

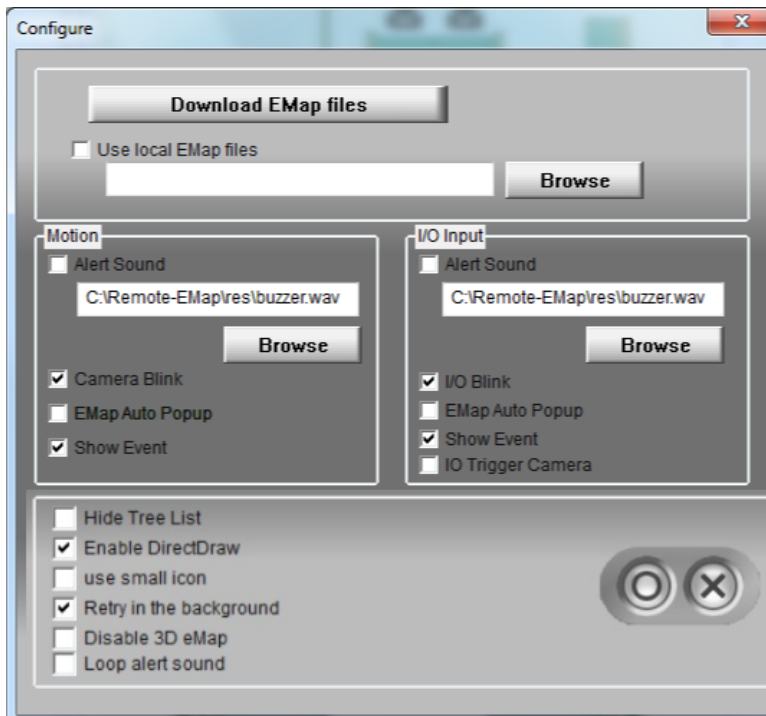

Figure 8-19

[Download E-Map files] Download E-Map files from the local server to the client PC. This option can reduce network loading if you wish to view the E-Maps of multiple hosts.

- **Use local E-Map files:** After downloading E-Map files to the client PC, you can select and use these E-Map files for connection.

[Motion] / [I/O Input]

- **Alert Sound:** Assign a .wav file to alert the operator when cameras or I/O devices are triggered.
- **Camera Blink, I/O Blink:** When cameras or I/O devices are triggered, their icons on the E-Map flash. Deselect this option to stop the icons from blinking.
- **E-Map Auto Popup:** When cameras or I/O devices are triggered, the related map will pop up on the screen instantly when the Remote-E-Map window is minimized.
- **Show Event:** Display motion or I/O triggered events on the Host Information window.
- **I/O Trigger Camera:** When input devices are triggered, the related camera views will pop up. To enable this function, you must map input devices to cameras on the GV-VMS first. See *Setting Live View Pop-up Video* in Chapter 1.
- **Hide Tree List:** Check to hide the tree list.
- **Enable DirectDraw:** By default, DirectDraw is enabled to speed up graphics rendering. Some VGA cards might not support DirectDraw and can produce distorted frames. In this case, disable the option.
- **Use Small Icon:** Enable for devices to be displayed by smaller icons.
- **Retry in the Background:** When the Remote E-Map is disconnected from GV-VMS, a warning message will pop up every 30 seconds. Select to hide the message and retry the connection in the background.
- **Disable 3D eMap:** E-Maps on Remote E-Map are displayed in 3D by default. Select to view the E-Maps in 2D view.
- **Loop alert sound:** When **Alert Sound** is enabled, the assigned .wav file will be played repeatedly until it is turned off by the operator.

8.4.4 Viewing Event List and Playing back Videos

You can see a list of triggered events on the Host Information window and play back the desired video(s).

1. Click **Host Information**  on the Remote E-Map window. The Host Information window appears.

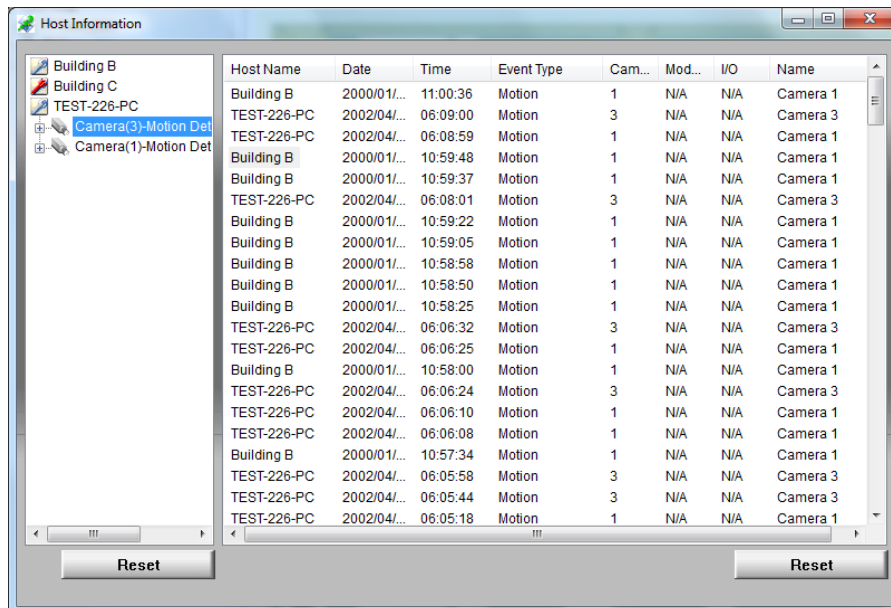

Figure 8-20

2. For event playback, double-click any motion event on the left panel. The player appears.
3. Optionally right-click the image to access the advance functions of the player.

8.5 E-Map Server

The E-Map Server is an independent program designed to create E-Maps for different hosts. With E-Map Server, you can monitor different sites on electronic maps through any computer accessible to the network.

8.5.1 Installing E-Map Server

You can install GV-E-Map Server from the [GeoVision Website](#).

8.5.2 The E-Map Server Window

Go to **Windows Start**, find **Programs**, select **eMapServer** and click **E-Map Server**. This window appears.

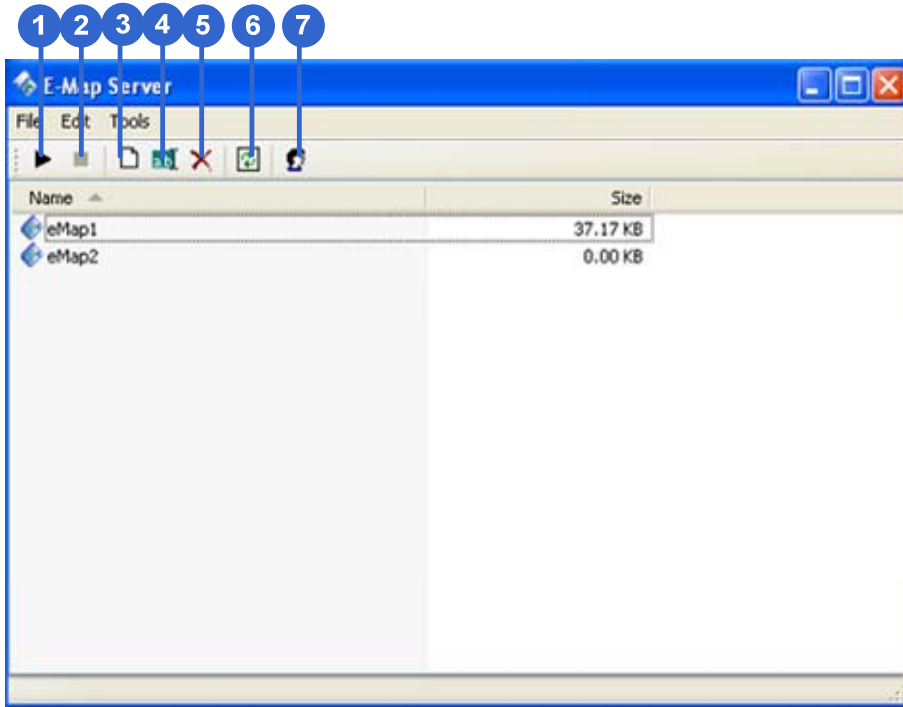

Figure 8-21

No.	Name	Description
1	Start Service	Starts the E-Map Server.
2	Stop Service	Stops the E-Map Server.
3	New	Creates a new E-Map file.
4	Rename	Renames the E-Map file.
5	Delete	Deletes the E-Map file.
6	Refresh	Refreshes the E-Map Server window.
7	Accounts	Creates user accounts of the E-Map Server.

8.5.3 Setting up E-Map Server

Before starting the E-Map server, you must create E-Map files and user accounts.

- To create E-Map(s), click **New** (No. 3, Figure 8-21). See *Creating an E-Map* earlier in this chapter.
- To create a user account for the server, click **Accounts** (No. 7, Figure 8-21).

8.5.4 Connecting to E-Map Server

With E-Map Server, you can monitor different sites on electronic maps through any computer accessible to the network.

1. Open the Web browser and type the IP address of the E-Map server.
2. Type the login info of the E-Map Server. You are prompted to select an E-Map (.emp) file.
3. Click **OK**. The Remote E-Map window appears (Figure 8-16).
4. Click **Login**  to log into the desired host(s). For details, see *Accessing E-Maps of Multiple Hosts* earlier in this chapter.

Note: To log into GV-VMS, make sure WebCam Server is enabled. See *Remotely Accessing E-Map* earlier in this chapter.

Chapter 9

Useful Utilities	280
9.1 Dynamic DNS	280
9.1.1 Running Dynamic DNS.....	281
9.1.2 Registering Domain Name with DDNS.....	281
9.1.3 Starting Dynamic DNS.....	282
9.2 Watermark Viewer	283
9.2.1 Activating Watermark Protection	283
9.2.2 Running the Watermark Proof	283
9.2.3 The Main Window.....	284
9.3 Windows Lockup.....	285
9.3.1 The GV-Desktop Screen.....	285
9.3.2 GV-Desktop Features	286
9.3.3 Token File for Safe Mode.....	288
9.4 Authentication Server.....	289
9.4.1 Installing the Server	289
9.4.2 The Main Window.....	290
9.4.3 Creating Clients.....	291
9.4.4 Creating User Accounts	292
9.4.5 Importing Groups and Users from Active Directory	295
9.4.6 Starting the Server.....	298
9.4.7 Connecting GV-VMS to the Server	300
9.4.8 Remote Access from Control Center and Remote E-Map.....	302
9.5 Fast Backup and Restore.....	305
9.5.1 Running the FBR Program.....	305
9.5.2 Plugin Component.....	306
9.5.3 Customizing the Features	307
9.5.4 Backing up and Restoring Settings	308
9.6 Bandwidth Control Application.....	311
9.6.1 Installing the Bandwidth Control	311
9.6.2 The Main Window.....	312
9.6.3 Allowing Remote Control	313
9.6.4 Connecting to a WebCam Server.....	314
9.6.5 Controlling Specific WebCam Server	315

9.6.6	Setting up the Bandwidth	316
9.6.7	Block List Setup	317
9.6.8	General Setup	318
9.7	Language Setting	319
9.7.1	Installing the MultiLang Tool	319
9.7.2	Revising the Translated Text	320
9.7.3	Setting the UI Language to English.....	323
9.8	GV-SD Card Sync Utility	324
9.8.1	Installing GV-SD Card Sync Utility.....	324
9.8.2	Setting up GV-SD Card Sync Utility	325
9.8.3	The Main Window.....	328
9.9	The Media Man Tools Window.....	329
9.9.1	The Media Man Tools Window	329
9.9.2	Viewing Disk Drive Status	330
9.9.3	Adding a Disk Drive	332
9.9.4	Removing a Disk Drive	333
9.9.5	Logging in Automatically at Startup.....	334
9.9.6	Setting LED Panel	334
9.10	Alert Notifications through SNMP Protocol	337
9.11	Local and Remote Backup	338
9.11.1	Remote Backup	338
9.11.2	Local Backup	338
9.11.3	Advanced Settings	340
9.11.3.1	Advanced Settings for Local Backup.....	340
9.11.3.2	File Transfer Settings for Local Backup	341
9.12	Report Generator	343
9.13	GV-Cloud Center	343

Useful Utilities

GV-VMS supports some advanced utilities to enhance the system performance in a security network.

9.1 Dynamic DNS

GV-Dynamic DNS provides domain name registration, making your dynamic IP address point to your GV-VMS server. The GV-Dynamic DNS will update the server's IP address to DNS Server every 10 minutes. Even if your server's IP address changes, you can still locate it by using the registered domain name.

Note: GV-Dynamic DNS uploads IP addresses over the Internet through ports 80 and 81. If your GV-VMS server is connected behind a router or firewall, make sure ports 80 and 81 are enabled. GV-Dynamic DNS will only upload global IP addresses. If your GV-VMS server is using virtual IP, NAT port mapping should be done first.

IMPORTANT: The DDNS service simplifies the process of trying to connecting an IP video device to the network. However, GeoVision does not and cannot warrant that the DDNS service will be uninterrupted or error free. Please read Terms of Service carefully before using the service. Besides GeoVision, you can also obtain the free DDNS service from these providers: DynDNS.org and No-IP.com.

9.1.1 Running Dynamic DNS

GV-Dynamic DNS Service is included in the installation of GV-VMS. Go to **Windows Start > Programs > GV-VMS > DNS Client V2**. The DNSClient V2 dialog box appears.

9.1.2 Registering Domain Name with DDNS

1. Click **Register** on the DNSClient V2 dialog box. The registration page appears.



Figure 9-1

2. Type a username and password and the Word Verification code. The password must be at least 6 characters.
3. Click the **Send** button. The following message appears.

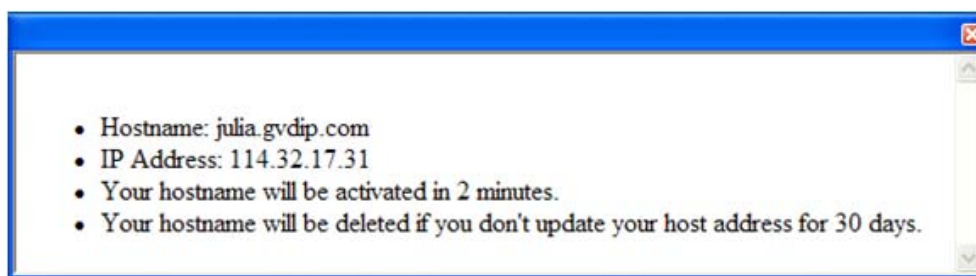

Figure 9-2

- **Hostname:** Made by registered username and “gvdip.com”. In this example, the hostname is “http://julia.gvdip.com”. This will be the domain name used to log into your server.
- **IP Address:** Your server’s current IP address. This IP address is updated every 10 minutes.

Note: The domain name .gvdip(xx).com may vary with xx from 01 to 99.

9.1.3 Starting Dynamic DNS

After registering a domain name with GV-Dynamic DNS, enable the DDNS function on your server. Run **DDNS Client V2** (Figure 9-1) and be sure GeoVision software is also enabled at the background.

After typing the **Hostname** and **Password** used to enable the Dynamic DNS service, complete the following settings:

- **Obtain an IP address automatically:** The DDNS server will use any available IP address from the server or the router.
- **Use the following IP address:** If your server or router has more than one IP address, you can assign one IP address to connect between the DDNS server and GV-VMS. It is highly suggested to assign a fixed IP address instead of a dynamic IP address, which will not be accessible for the DDNS when the IP address is changed.
- **Run at startup:** Select to automatically run the DDNS service at Windows startup.
- **E-mail Setting:**
 - **Scheme:** Select a given situation to receive e-mail notification.
 - **Sender:** Type the name, e-mail address, username and password of the sender.
 - **Receiver:** Type the recipient's e-mail address(es). For multiple recipients, add a semicolon between each e-mail address.
 - **Mail Server:** Type the host name or address of your mail server. Keep the default port 25 or modify if the mail server uses a different port. Select **SSL** if your e-mail server requires the SSL authentication for connection.
 - Click the **Test** button to send a test e-mail to confirm if the settings are correct.

Click **Save**. The connection information will be displayed.

Note: The DNS Client will not upload the IP address unless the compatible GeoVision software is running such as GV-VMS. If the IP address of your server is not updated for more than 30 days, your host name will be deleted automatically.

9.2 Watermark Viewer

The GV-VMS can embed digital watermarks in video streams for authentication purposes. The watermarks are encrypted with digital signatures in video streams during the compression stage, ensuring that images are not edited or damaged after they are recorded. In addition, you can apply the **Watermark Proof**, a watermark-checking program included in the installation of the GV-VMS, to further verify the authenticity of the recording.

Note: To run the **Watermark Proof** application in the backup file on your PC without GV-VMS, you must register the GeoVision Video Codec manually (go to the recorded files' location > GeoCodecReg folder > double-click **GeoCodecReg**).

9.2.1 Activating Watermark Protection



To enable the watermark protection, click **Home**  > **Toolbar**  > **Configure**  > **System Configure** > **Record Setting**. Select **Use Digital Watermark Protection** and click **OK**. The GV-VMS will digitally sign videos during the recording.



Figure 9-3

9.2.2 Running the Watermark Proof

1. Go to the GV-VMS folder and run **WMPProof.exe**. The Watermark Proof window appears.
2. Click **File** from the menu bar, select **Open**, locate the recorded file (.avi) and click **Open**. The selected file is listed on File List (No. 9, Figure 9-4). Alternatively, you can directly drag the file from the storage folder to the window.
 - If the recording is unmodified, a check mark will appear in the **Pass** column.
 - If the recording is modified or does not contain watermark during recording, a check mark will appear in the **Failed** column.
3. To play the recording, double-click the listed file on the window.

9.2.3 The Main Window

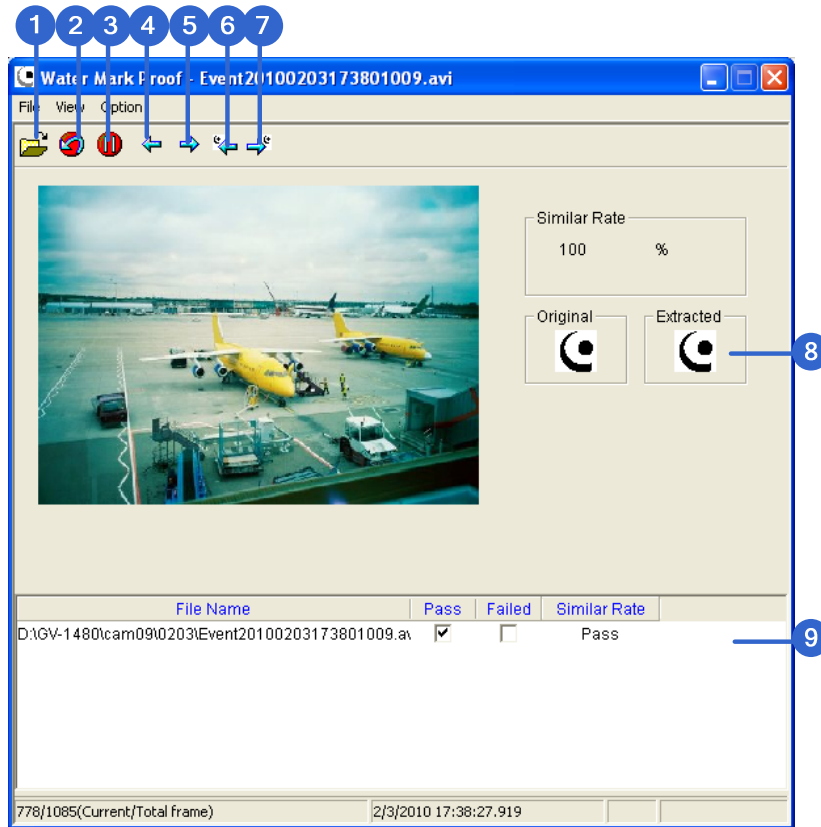

Figure 9-4

No.	Name	Description
1	Open File	Opens the recorded file.
2	First Frame	Goes to the first frame of the file.
3	Play	Plays the file.
4	Previous Frame	Goes to the previous frame of the file.
5	Next Frame	Goes to the next frame of the file.
6	Previous Watermark Frame	Goes to the previous frame that contains watermark.
7	Next Watermark Frame	Goes to the next frame that contains watermark.
8	Original vs. Extracted	The Extracted icon should be identical with the Original icon. If not, it indicates the recording has been tampered.
9	File List	Displays the proof results.

9.3 Windows Lockup

The GV-Desktop helps you secure your computer while away from your workstation. You may lock up the Windows desktop while launching a customized GV-Desktop. In the GV-Desktop, users are limited to run the GV-VMS and selected programs.

9.3.1 The GV-Desktop Screen

The GV-Desktop is included in the installation of GV-VMS. Go to **Windows Start > Programs > GV-VMS > Key Lock Utility**. The GV-Desktop screen appears.

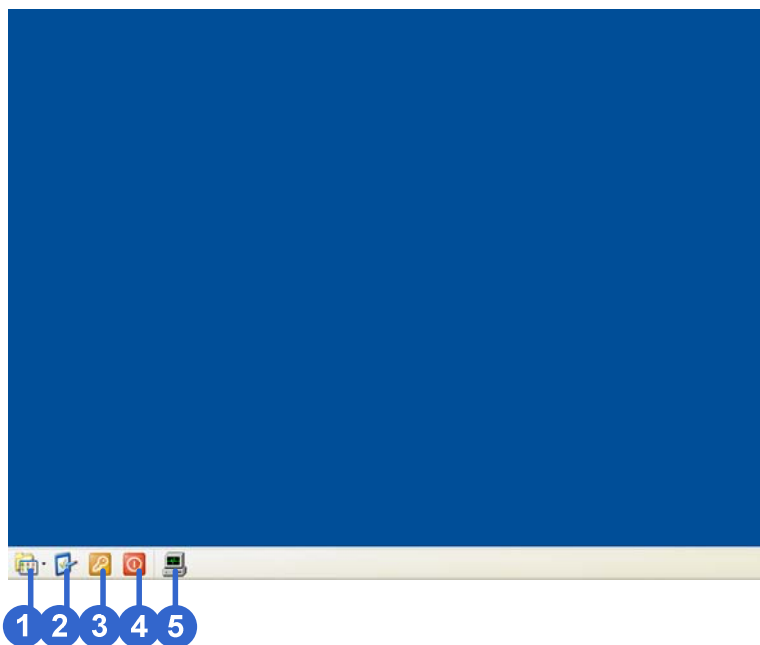

Figure 9-5

No.	Name	Description
1	Programs	Accesses programs.
2	Settings	Adds programs to the programs menu.
3	Log Off	Logs off GV-Desktop.
4	Shut Down	Shuts down the computer.
5	Task Manager	Views the tasks currently running on your computer.

9.3.2 GV-Desktop Features

Programs

Click the **Programs** button (No.1, Figure 9-5) to see the program menu. The default programs are Video Management System (GV-VMS), Repair Database Utility, eMap Editor and Control Center Service. To add or remove new programs to the menu, see the *Settings* section later in this chapter. In the example below, Paint is a new program added to the menu.

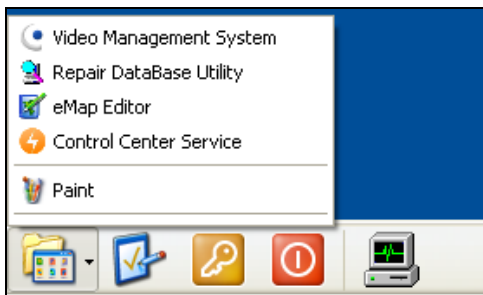

Figure 9-6

Settings

Click the **Settings** button (No.2, Figure 9-5) and type the valid ID and password. This window appears.

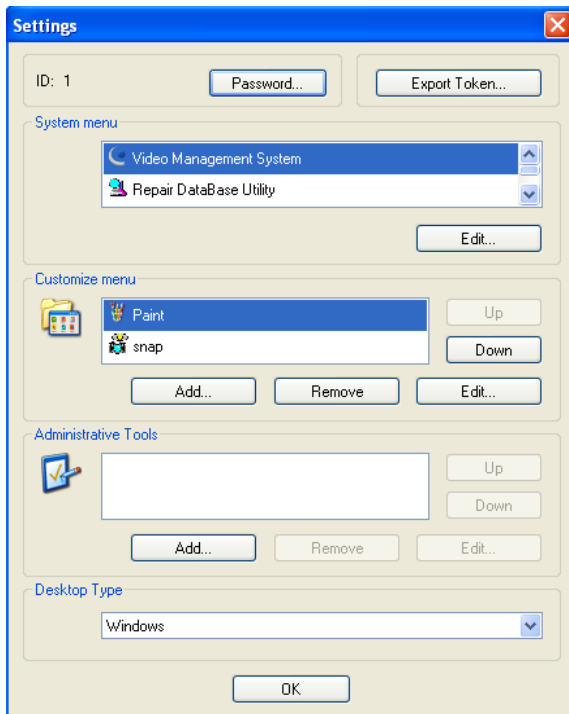

Figure 9-7

[Password] Change the password. For the **Allow Removing Password System** option, see *Account and Password* in Chapter 1.

[Export Token] See *Token File for Save Mode* later in this chapter.

[System Menu] Select a desired program and click the **Edit** button to change its name.

[Customize Menu] Set up the Programs menu as desired. To add a program, click the **Add** button. In the Shortcut dialog box, type the program name, click the button next to the field to assign a path and click **OK**.

[Administrative Tools] Set up the Programs menu as instructed in *Customized Menu* option. To run the added programs configured in the Administrative Tools field, the administrative ID and Password are required.

[Desktop Type] Select Windows or GV-VMS from the drop-down menu. The selected desktop will launch the next time when you log into the computer.

Log Off

Click the **Log off** button (No.3, Figure 9-5) to log off GV-Desktop with a valid ID and password.

Shut Down

Click the **Shut Down** button (No. 4, Figure 9-5) to shut down your computer with a valid ID and password.

Task Manager

Click the **Task Manager** button (No. 5, Figure 9-5) to view the programs which are currently running on your computer. When you minimize a program, it will be hidden and under operation in the background. To bring the program back to desktop, double-click the program listed in Task Manager.

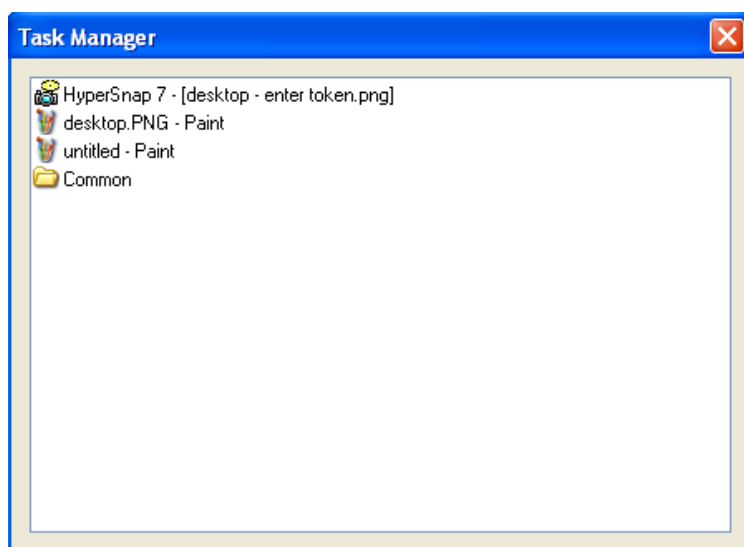

Figure 9-8

9.3.3 Token File for Safe Mode

This option in the Settings section lets you export a token file. In case you enter safe mode and are in the status of the GV-Desktop, this token file allows you to exit from the GV-Desktop and enter the Windows desktop. To export a token file, follow the steps below.

Exporting the Token File

1. Click the **Export Token** button (Figure 9-7). The Enter Token Code appears.
2. Type a code in the Token Code field and click **OK**.
3. In the Save As dialog box, locate a path, type a desired name in the File Name field and click **Save** to save the file.

Switching from GV-Desktop to Windows Desktop

1. Click the **Settings** button on the GV-Desktop. You will be prompted to locate the stored token file and type the configured token code.
2. When the Settings window (Figure 9-7) appears, select **Windows** in the Desktop Type field and exit from the window.
3. Click the **Log Off** button to log off the GV-Desktop and run the Windows desktop. You need to locate the stored token file and type the configured token code again.

9.4 Authentication Server

GV-Authentication Server is a password and account management system for multiple GV-VMS. Through the Authentication Server, the administrator can create the accounts with different access rights to a group of GV-VMS. Once any GV-VMS is connected to the Authentication Server, the previous password settings in local GV-VMS will be invalid. Local GV-VMS will submit to the full control of the Authentication Server.

Note: In addition to the GV-VMS, the Authentication Server also supports GV-System, E-Map Server and GV-Control Center V3.1.2.0 or earlier for central credential management. Up to 20,000 client accounts can be created.

9.4.1 Installing the Server

You can install **GV-Authentication Server** from **Install GeoVision supplemental Utilities** in the Software DVD or [GeoVision Website](#).

9.4.2 The Main Window

Go to **Windows Start > Programs > AuthServer > AuthServer**. This window appears.

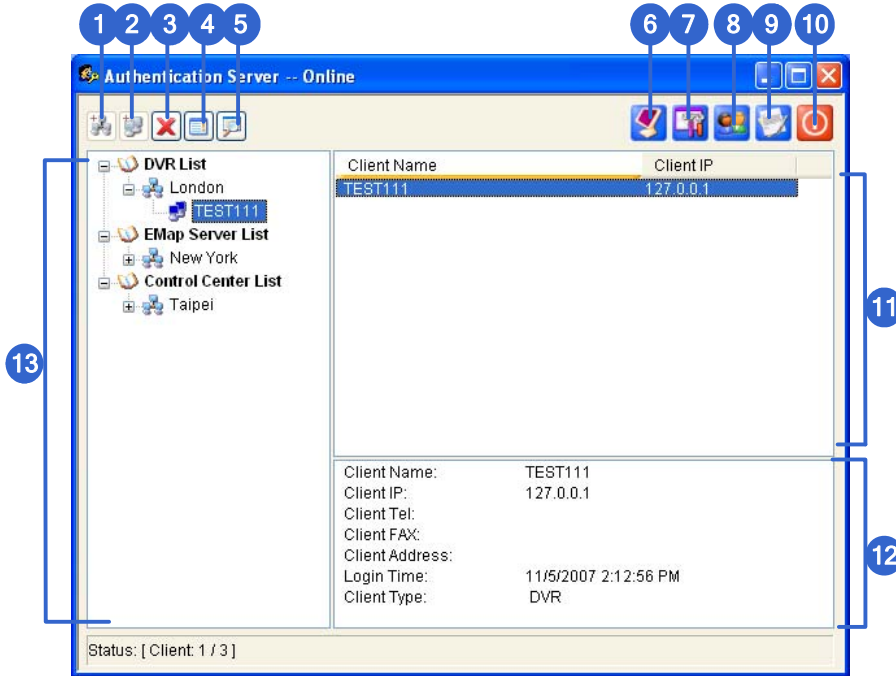



Figure 9-9

No.	Button	Description
1	Add An Area	Creates an Area group.
2	Add A Client	Creates a client account.
3	Delete An Area / Client	Deletes an existing group or client.
4	View/Edit A Client	Select a client from the Client List, and click to view / edit it.
5	Find A Client	Finds an existing client.
6	Start/Stop Service	Starts/Stops the Authentication Server.
7	Server Setup	Configures the Authentication Server.
8	Account Setup	Configures passwords and grants permissions to clients. Imports groups from Active Directory.
9	Log	Sets up the Authentication Server Log and opens the log browser.
10	Exit	Exits this window; Logs out Administrator; Changes Password, imports or exports account information.
11	Connected Client List	Lists the connected GV-VMS, GV-System, E-Map Server or GV-Control Center.
12	Client Information	Lists the information of the selected GV-VMS, GV-System, E-Map Server or Control Center.
13	Client List	Sets up the Authentication Server Log and opens the log browser.

9.4.3 Creating Clients

You must create and arrange the clients first which user credentials will be centrally managed by the Authentication Server. To create a list of GV-VMS clients, follow the steps below.

1. To create a GV-VMS client, highlight the **DVR List** from the left panel and click the **Add A Client** button . The Client Information dialog box appears.

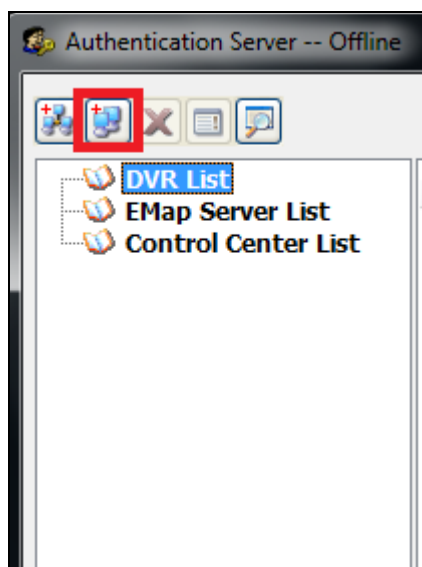



Figure 9-10

2. Type the client's information and click **OK**. The **Name** must match that of local GV-VMS.

Tip: To view the name of your GV-VMS server, select **Toolbar**  > **Configure** > **System Configure** > **General Setting**.

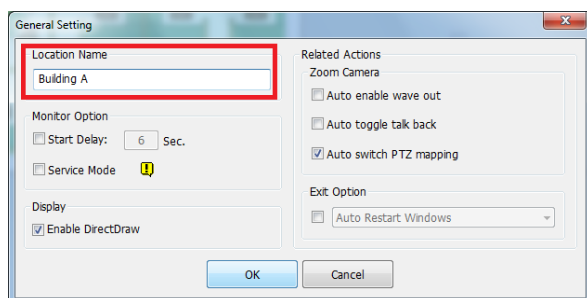

Figure 9-11

3. To create another client, repeat the steps above.
4. You can also arrange multiple clients under a group by highlighting a list and clicking the **Add An Area** button (No. 1, Figure 9-9). The created group appears under the selected List.

9.4.4 Creating User Accounts

To create user accounts with different access rights and assign the user accounts to a group of GV-VMS clients, follow the steps below. Up to 20,000 accounts can be created.

1. Click the **Account Setup** button (No.8, Figure 9-9) and select **Password Setup**. The Password Setup dialog box appears.
2. To create and edit a user account, refer to *Account and Password* in Chapter 1.

Note: The Administrator has the authority of changing the password of any accounts.

3. To assign the created user to a group of GV-VMS clients:
 - A. Click the **Group Setting** button.

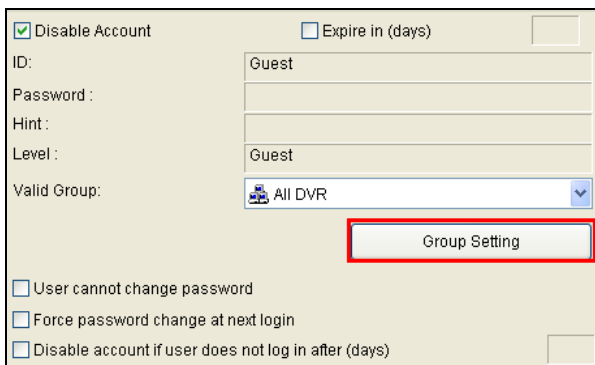

The screenshot shows a dialog box for user account setup. It includes fields for ID (Guest), Password, Hint, and Level (Guest). The 'Valid Group' dropdown is set to 'All DVR'. A 'Group Setting' button is highlighted with a red rectangle. There are also checkboxes for 'Disable Account', 'Expire in (days)', 'User cannot change password', 'Force password change at next login', and 'Disable account if user does not log in after (days)'.

Figure 9-12

- B. In the Valid Group List window, click the **New Group** button.

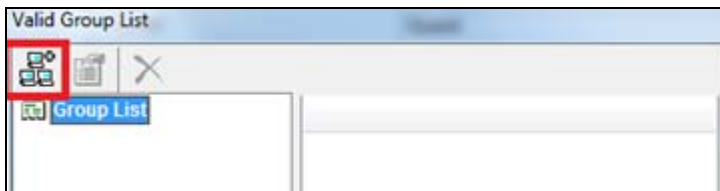

Figure 9-13

- C. In the DVR Group Information window, give a name to the group, select the desired GV-VMS clients to be added to the group. Click **OK**.

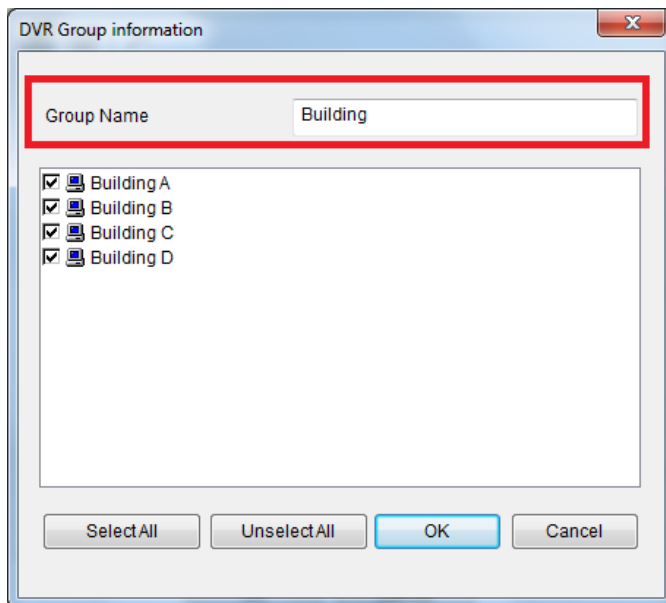

Figure 9-14

- D. Click **OK** again to return to the Password Setup window.
- E. Use the **Valid Group** drop-down list to select the created group. The user will be able to log in the assigned GV-VMS clients.

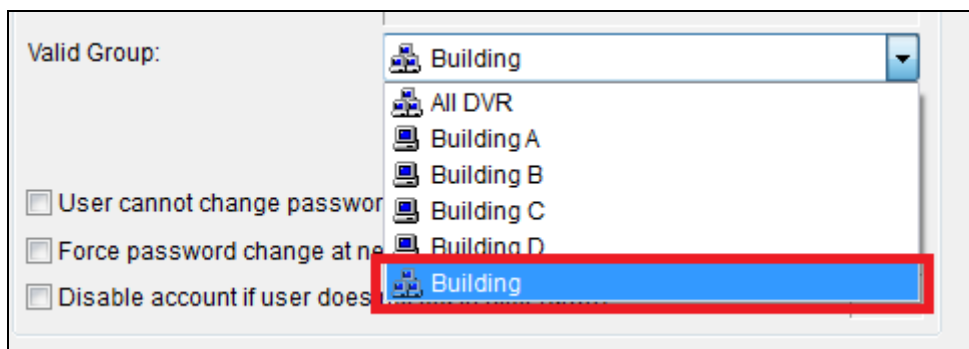

Figure 9-15

4. Optionally use the following functions to arrange the user and client accounts.
 - A. Right-click a user account to have two options. The **Apply setting to** option will apply the same settings to a specific user account. The **Apply setting to group** option will apply the same settings to all user accounts under the same account level.

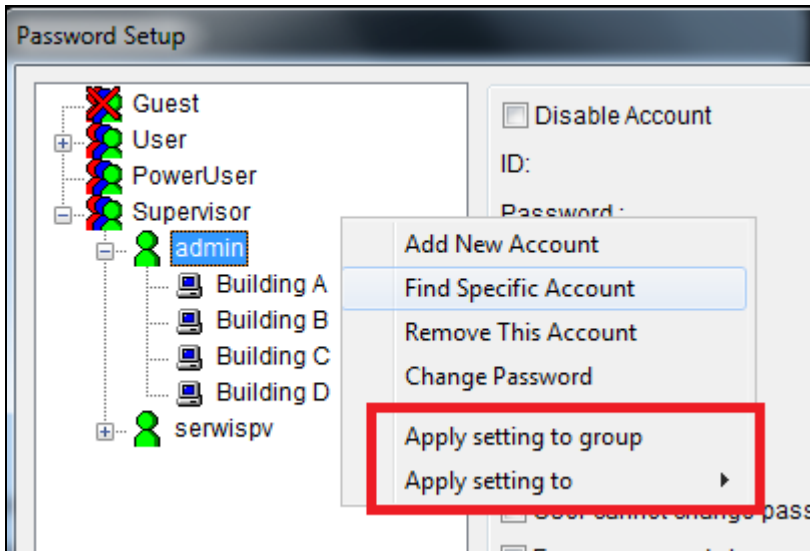

Figure 9-16

- B. Right-click a client account to have two options. The **Apply setting to other DVR(s)** option allows you to apply the same settings to all clients under the same user account. For this example, the settings of Building A client will be applied to all Building B, C and D clients. The **Copy** option allows you to copy and paste one client's settings and any client.

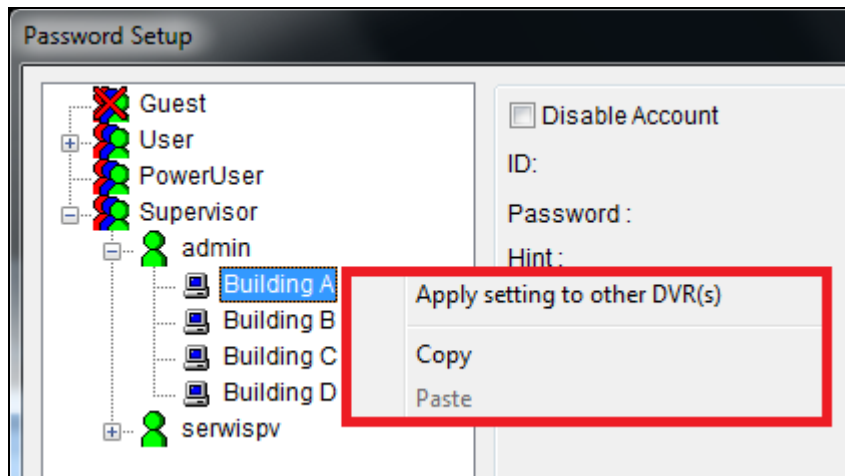

Figure 9-17

9.4.5 Importing Groups and Users from Active Directory

To create user accounts efficiently, you can import groups and users from Microsoft's Active Directory to Authentication Server. You will need to install Active Directory on Windows Server and set up users into groups before following the steps below.

Note: User accounts in Active Directory need to be grouped into Groups settings first as only groups can be imported into Authentication Server.

1. Run **Active Directory Domains and Trusts** in Windows Server by clicking the **Start** menu and opening **Administrative Tools**.
2. Right-click your local Active Directory system and select **Manage**. The Active Directory Users and Computers dialog box appears.

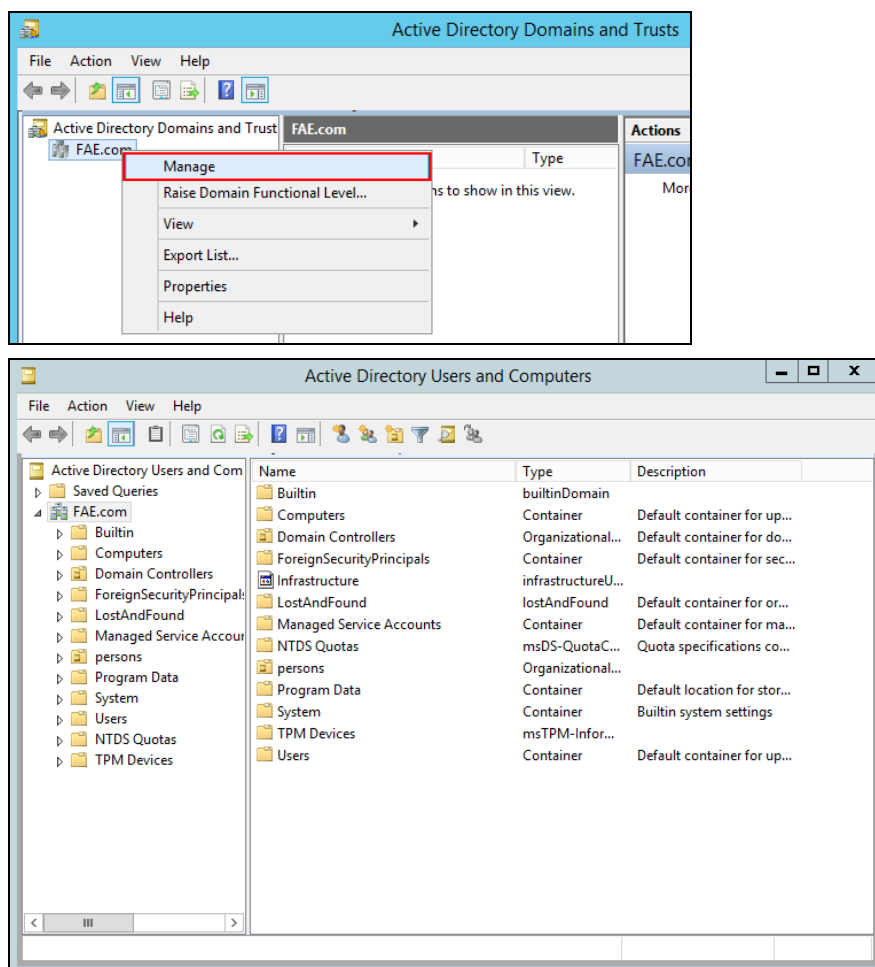

Figure 9-18

3. On the **View** menu, select **Advanced Features**.

Note: If you use Windows Server 2008 instead of Server 2012, skip this step.

4. Right-click the folder saved with the user accounts or groups and select **Properties**.

Tip: You can change the query parameters or show all items for each folder by clicking **View** and selecting **Filter Options**.

5. Select the **Attribute Editor** tab, double-click the attribute **distinguishedName** and copy the value like **OU=persons,DC=FAE,DC=com**. You will need to paste the value at *step 8, C* to assign the folder to import the user accounts or groups.
6. In AuthServer, click the **Account Setup** button (No.8, Figure 9-9) and select **Active Directory Setup**. This page appears.

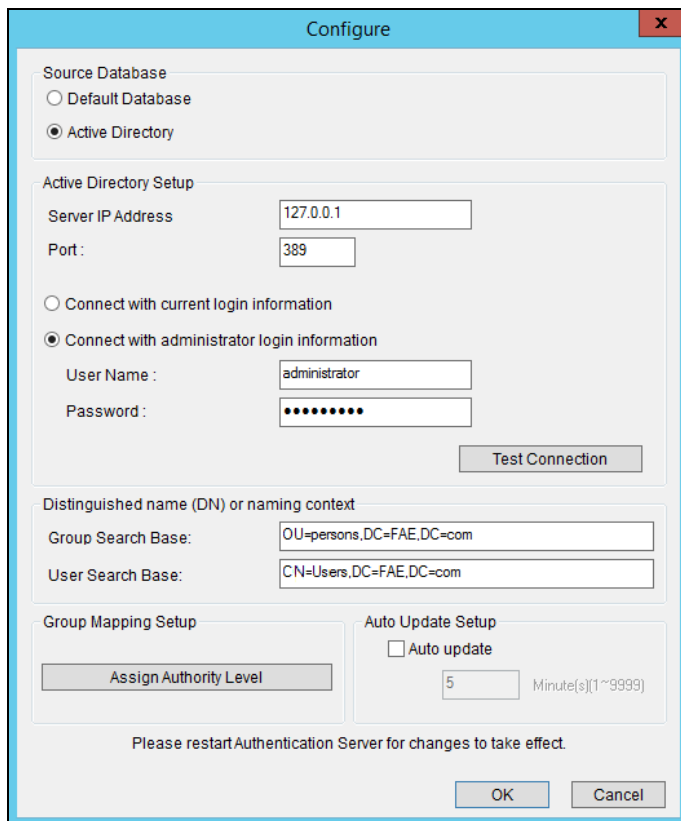

Figure 9-19

7. Under Source Database, select **Active Directory** to enable the function.
8. To connect to the server with Active Directory:
 - A. Type the **Server IP Address** and the **Port** number of the server.

- B. To log into the server using your current login information, select **Connect with the current login information**. To log into the server using the login information of its administrator, select **Connect with administrator login information** and type the user name and password.
 - C. Paste the value of distinguished name you copied at step 5 respectively to **Group / Users Search Base**.
 - D. Click **Test Connection** to see if you can connect to the server with Active Directory.
9. To assign groups in Active Directory to User, Power User or Supervisor authority levels:
 - A. Click the **Assign Authority Level** button. This dialog box appears.

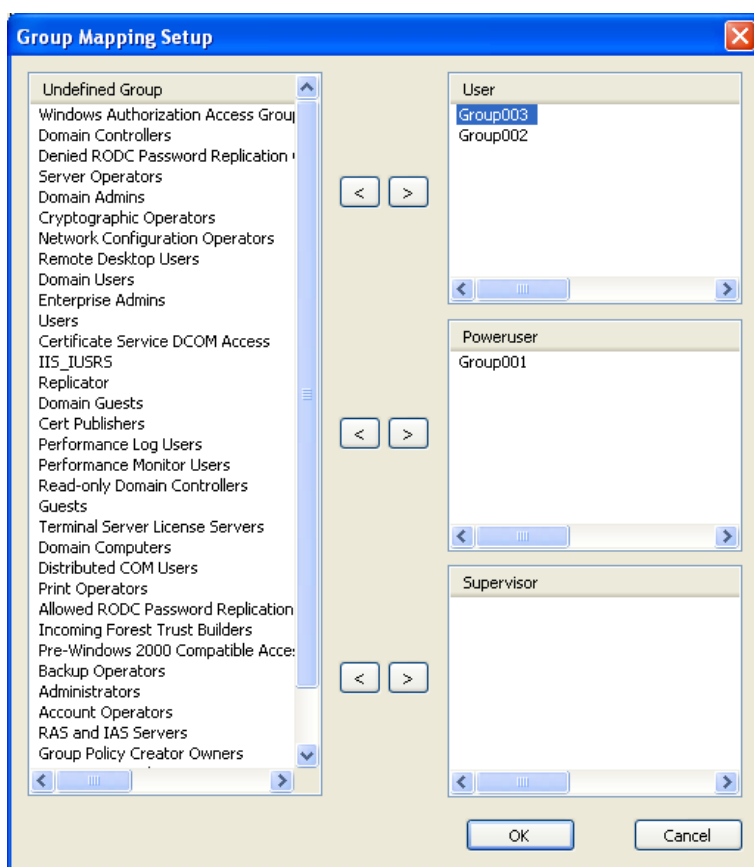

Figure 9-20

- B. Select the groups detected in Active Directory from the Undefined Group list and use the arrow buttons to assign the groups to User, Power User or Supervisor level.
 - C. Click **OK** to import the user data into the Password Setup window.
10. To automatically update changes to user data in Active Directory, click **Auto Update** and specify the update frequency in minutes.
 11. Click **OK** and restart Authentication Server to apply the settings.

9.4.6 Starting the Server

To configure the server and start the service, follow the steps below.

1. Click the **Server Setup** button (No. 7, Figure 9-9). This dialog box appears.

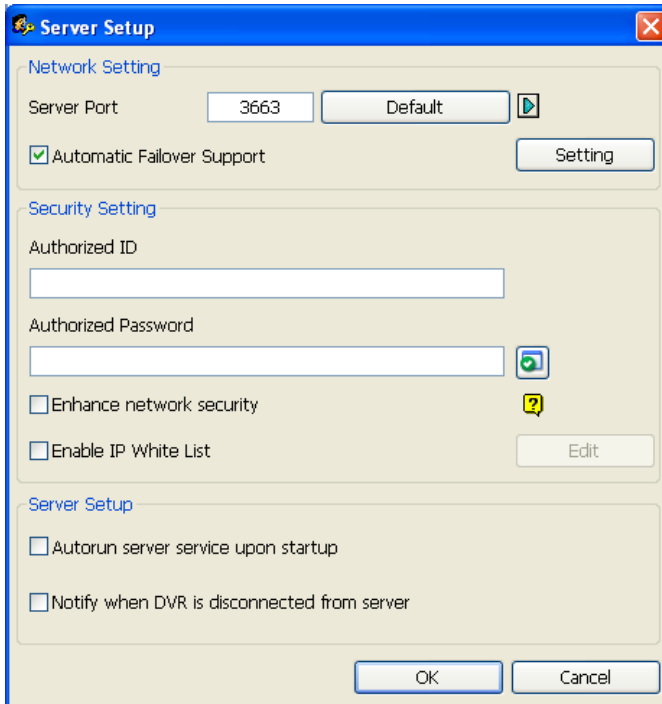

Figure 9-21

2. Under Security Setting, type the **Authorized ID** and **Authorized Password** which will be used for the client GV-VMS to log into the Authentication Server.
3. Click **OK** to apply the settings.
4. Click the **Start/Stop Service** button (No. 6, Figure 9-9) to start the services.

Optionally, you can configure the following settings before starting the Authentication Server:

[Network Setting]

- **Server Port:** The default port number is **3663**. To use UPnP for automatic port configuration to your router, click the **Arrow** button. For details, see *UPnP Settings* in Chapter 7.
- **Automatic Failover Support:** Select and click the **Setting** button to configure up to 2 Authentication Servers in case the primary Authentication Server fails. If fails, the second or the third server will take over the connection from clients and provide uninterrupted services. Note the settings of Authorized ID and Authorized Password on the failover server must match those of the primary server.

Tip: To set up the failover Authentication Server, you can export the current settings by using the **Export Account** and **Import Account** functions in the **Exit** button.

Note: Once the primary Authentication Server is ready to resume the services, close the failover Authentication Server so the connection from clients can move back to the primary.

[Security Setting]

- **Enhance network security:** Strengthen network security on Authentication Server.
- **Enable IP White List:** Click **Edit** to create a list of IP addresses only to establish connection with Authentication Server.

[Server Setting]

- **Auto run server service upon startup:** Starts the service automatically upon the startup of Authentication Server.
- **Notify when DVR is disconnected from server:** Notify the Authentication Server with a pop-up window when the GV-VMS is disconnected with the Authentication Server.

9.4.7 Connecting GV-VMS to the Server

To configure the GV-VMS in order to access the Authentication Server remotely through a network connection, follow the steps below.

1. On the main screen of GV-VMS, click **User** 1 > **Password Setup** > **Remote Authentication Setup**. The Setup Remote Authentication Server dialog box appears.

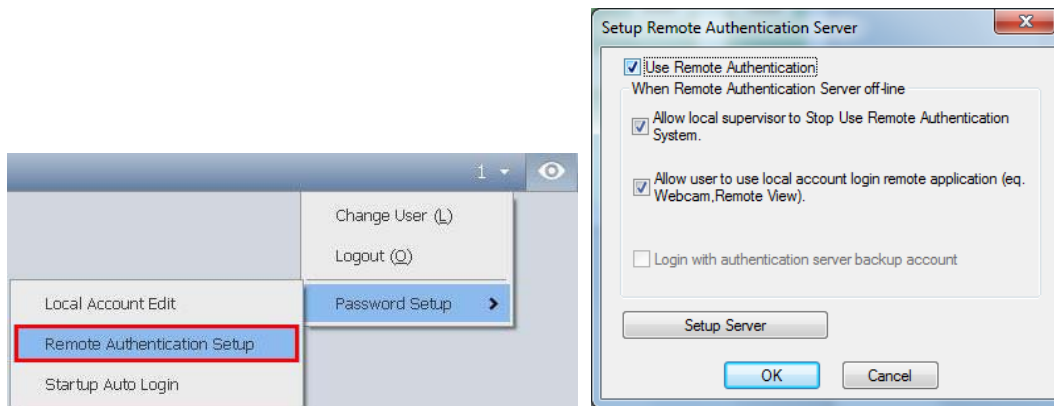

Figure 9-22

2. Select **Use Remote Authentication** and optionally select:

[When Remote Authentication Server Off-line]

- **Allow local supervisor to stop use Remote Authentication System:** Allow the local supervisor to stop the Authentication application when the connection fails with the Authentication Server. Note if the option is disabled and the connection fails with Authentication Server, the local supervisor will not be able to log into the GV-VMS, and the dialog box will not be accessible until the connection resumes.
 - **Allow user to use local account login remote application:** Allow local users to access remote applications with their previous password and ID settings when the connection with the Authentication Server fails.
 - **Login with authentication server backup account:** Keep using password settings created on the Authentication Server even though the connection with the server fails.
3. Click **Setup Server**. The Remote Authentication dialog box appears.
 4. Type the IP address and port of the Authentication Server.
 5. Type the **Authorized ID** and **Authorized Password** of the Authentication Server.
 6. Click **OK** to start the connection. When the connection is established, the previous password settings in the GV-VMS will be invalid.



7. Press **[L]** on the keyboard to call up the Login dialog box. The icon  indicates that the connection is established.



Figure 9-23

As long as the Authentication Server works, the Login dialog box will appear upon the starting of GV-VMS. Type the user account created on the Authentication Server to log into the GV-VMS.

Note: The disconnection icon  will appear on the Login dialog box (Figure 9-23) when one of the following situations occurs:

1. The login ID and Password do not match any of the user IDs and Passwords created on the Authentication Server.
 2. The client name does not match the location name of GV-VMS (Figure 9-11).
 3. The network connection encounters traffic problem.
-

9.4.8 Remote Access from Control Center and Remote E-Map

The Authentication Server allows you to restrict users of E-Map Server and GV-Control Center to access specific GV-VMS hosts and cameras only. Instead of connecting to GV-VMS hosts directly, the user of E-Map Server and Control Center will connect to the Authentication Server using the user account you created on the Authentication Server.

You must first set up remote authentication on E-Map Server and GV-Control Center. After the E-Map Server and GV-Control Center are connected to the Authentication Server, the user will be prompted to log in with the user ID and password you created on the Authentication Server. Once the user logs in, a list of GV-VMS hosts authorized to the user account will be displayed, and the user will be able to view the assigned cameras.

Setting up Authentication Server

You need to create and arrange E-Map Servers and Control Servers under their separate lists on the Authentication Server window (Figure 9-9).

1. In the Client List field, click the E-Map Server List or Control Center List and click the **Add A Client** button (No. 2, Figure 9-9). The Client Information dialog box appears.
2. Type the name and information of the E-Map Server or Control Center. The name does not need to match the location name of the E-Map Server or Control Center.
3. Click **OK** to add the E-Map Server or Control Center.

Accessing from E-Map Server

The E-Map Server can access the user account setting of the Authentication Server.

1. Run the **E-Map Server**. For details, see *E-Map Server* in Chapter 8.

- In the E-Map Server window, click **Tools** on the menu bar, and select **Options**. This dialog box appears.

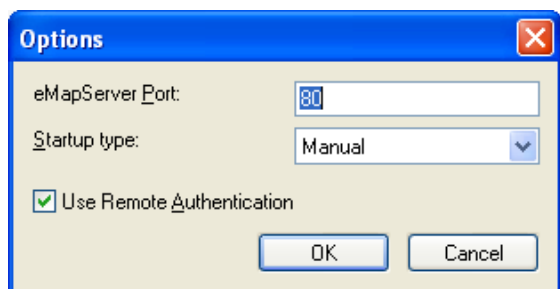

Figure 9-24

- Select **Use Remote Authentication**.
- To enable the Authentication Server service to start automatically at Windows startup, select **Automatic**. Keep the E-Map Server Port **80** as default or modify if necessary.
- Click **OK** to apply the settings.
- In the E-Map Server window, click **Tools** on the menu bar and select **Remote Authentication**. This dialog box appears.

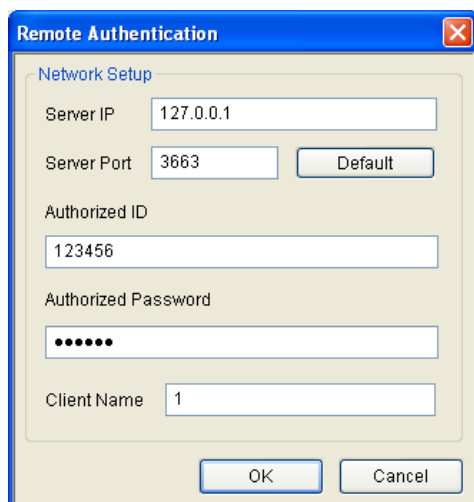

Figure 9-25

- Type the IP address, authorized ID and authorized password of the Authentication Server, as well as the E-Map Server's client name created on the Authentication Server, and then click **OK**.
- In the E-Map Server window, click **Tools** on the menu bar and select **Start Service** to start the E-Map Server.
- When you log into the E-Map Server, type the user ID and password created on the Authentication Server. A list of assigned GV-VMS clients to the user will be displayed.

Accessing from GV-Control Center

The GV-Control Center can access account settings of the Authentication Server.

Note: The Authentication Server only supports GV-Control Center V3.1.2.0 or earlier.

1. Run the **GV-Control Center**. For details, see [GV-Control Center User's Manual](#).
2. On the Host List, right-click **Host List by ID** and select **Remote Authentication Setup**. A dialog box appears.
3. Type the IP address, authorized ID and authorized password of the Authentication Server, as well as Control Center's client name created on the Authentication Server, and then click **OK** to enable connecting to the Authentication Server.
4. To access the Authentication Server account settings, on the Host List, right-click **Host List by ID** and select **Get Host List by ID**. A dialog box prompts you for ID and password.
5. Type a user ID and password created on the Authentication Server, and click **OK**. A list of assigned GV-VMS hosts to the user will be displayed.

9.5 Fast Backup and Restore

With the Fast Backup and Restore (FBR) solution, you can change interface skin and customize features to suit personal preference, as well as backing up and restoring your configurations in GV-VMS.

9.5.1 Running the FBR Program

Go to **Windows Start > Programs > GV-VMS > Fast Backup & Restore Main System**. You will be prompted to enter a valid ID and Password of GV-VMS, and then this window will appear.

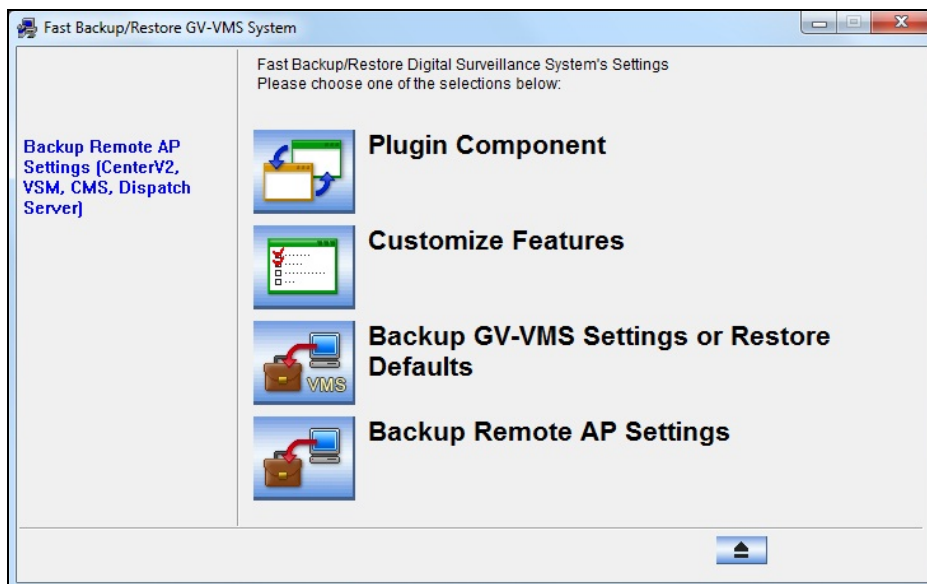

Figure 9-26

9.5.2 Plugin Component

You can add programs to your GV-VMS to expand the applications.

1. In the FBR window (Figure 9-26), click the **Plugin Component** icon. This dialog box appears.

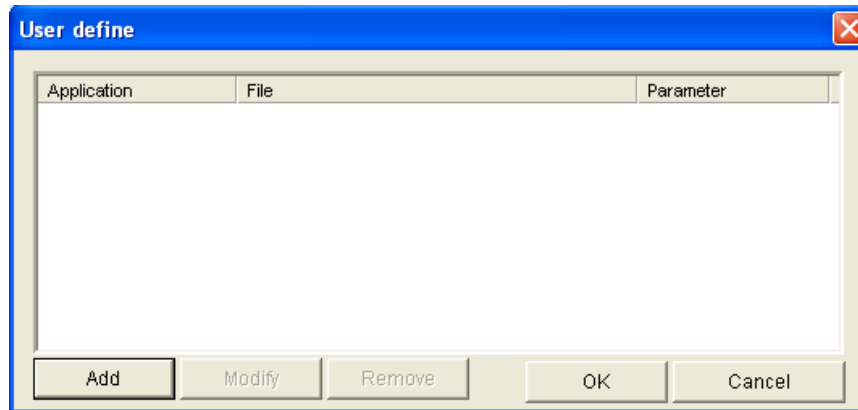





Figure 9-27

2. Click **Add**. The Add New Item dialog box appears.

Note: For some applications, type **/FBR** in the Parameter column if necessary.

3. Type the name of the desired application, locate its path and click **OK**.
4. To add more applications, repeat steps 1 to 3 and click **OK** in the User Define dialog box.
5. To access the added applications, run the GV-VMS, click **Home**  > **Toolbar**  > **Tools** , point to **Plugin** and select a desired application.

9.5.3 Customizing the Features

Not every feature may be of equal interest to you. You can specify which features are to be displayed at system startup.

1. In the FBR Window (Figure 9-26), click **Customize Features**. This dialog box appears.

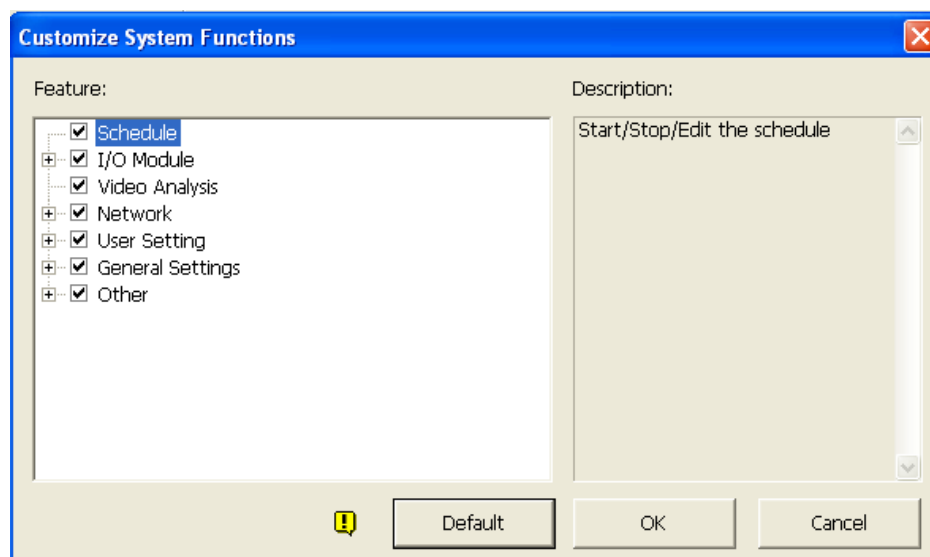



Figure 9-28

2. Expand the folder(s) and click the function(s) you want to disable in the GV-VMS.
3. Click **OK** to save the settings.
4. Restart GV-VMS for the settings to take effect.

9.5.4 Backing up and Restoring Settings

You can back up the configurations you made in the GV-VMS, and restore the backup data to the current system or import it to another GV-VMS.

Backing up the settings

1. In the FBR window (Figure 9-26), click the **Backup GV-VMS Settings or Restore Defaults** icon, and select **Backup Current System**.
2. Select which settings you want to back up and click the **Next Step** button .
3. In the Save As dialog box, select the destination to store the backup file. When the backup is complete, the “Successfully Backup GV-VMS System Settings” message will appear:

Restoring the System

You can restore the current system with the backup of configuration file. Also, you can copy this backup file to configure another system with the same settings as the current system.

1. Open the backup file (*.exe) you previously stored. A valid ID and password are required to display this window.

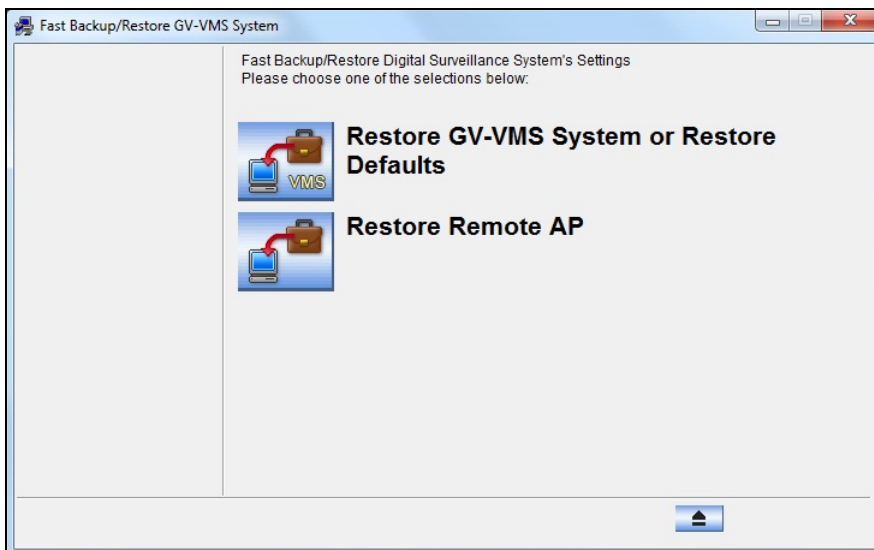



Figure 9-29

2. Click the **Restore GV-VMS System** icon and then select which backup settings you want to restore.

3. Click the **Next Step** button  to start restoring.
4. When the restoration is complete, the “Successfully Restore GV-VMS System Settings” message will appear.

Scheduling Configuration Backup

You can now set up a regular schedule with password protection to back up the GV-VMS configurations you made.

1. Go to **Windows Start > Programs > GV-VMS > Fast Backup & Restore Main System**. Type a valid ID and Password of GV-VMS as prompted.
2. Click **Backup GV-VMS Settings or Restore Defaults > Schedule Setup**.
3. Select **Active Schedule**.

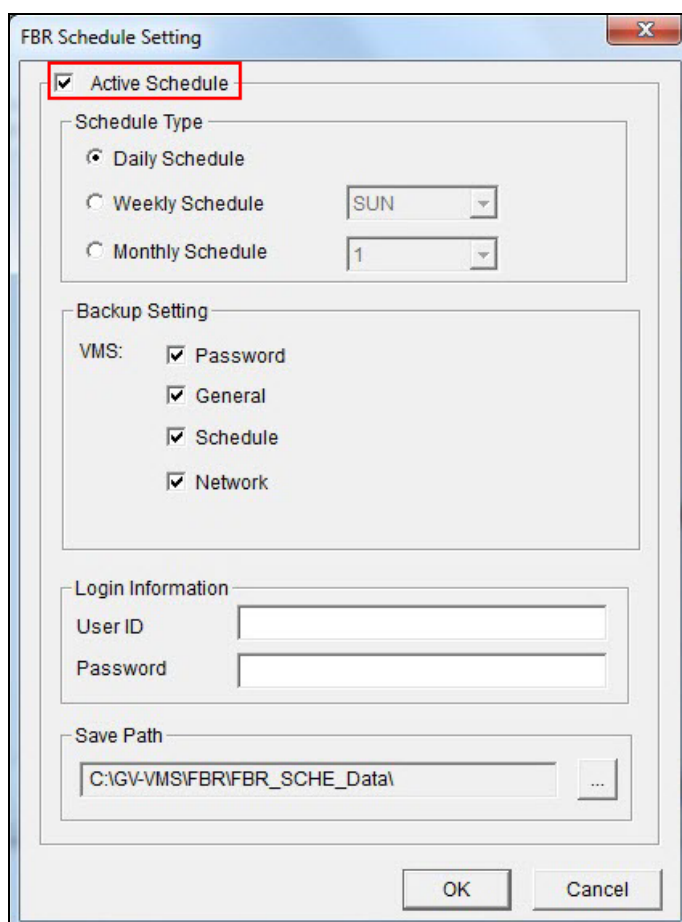

Figure 9-30

4. Select a desired schedule type.

5. Select desired options for backup.
 - **Password:** Back up all the user accounts and password settings of GV-VMS.
 - **General:** Back up all the settings of video analysis, IP devices, system configurations, Content List, E-Map, GV-Keyboard / GV-Joystick, and System Log.
 - **Schedule:** Back up the recording schedule configuration.
 - **Network:** Back up the network configuration of connection to VSM (Vital Sign Monitor) and to Center V2.
6. Type a user ID and password in the Login Information section. The ID and password must be identical with that of a user account created in GV-VMS. You will need to use this ID and password to restore the backup file.
7. Locate a path to save the backup contents.

Restoring Defaults

To restore the system default, click the **Backup GV-VMS Settings or Restore Defaults** icon (Figure 9-29), select **Restore Defaults** and follow the on-screen instructions to complete the process.

9.6 Bandwidth Control Application

The Bandwidth Control is an independent application that controls and monitors the network traffic of the WebCam servers. Its features include:

- Manage up to 5 GV-VMS systems
- Get bandwidth usages of every Webcam server and every user
- Set bandwidth thresholds for specific users and IP addresses
- IP black and white list
- Kick unwanted users

9.6.1 Installing the Bandwidth Control

You can install **GV-Bandwidth Control Client Site** from **Install GeoVision Supplemental Utilities** in the Software DVD or [GeoVision Website](#).

9.6.2 The Main Window

After the installation is complete, double-click the **Bandwidth Remote Control** icon created on the desktop. The Bandwidth Control window appears.

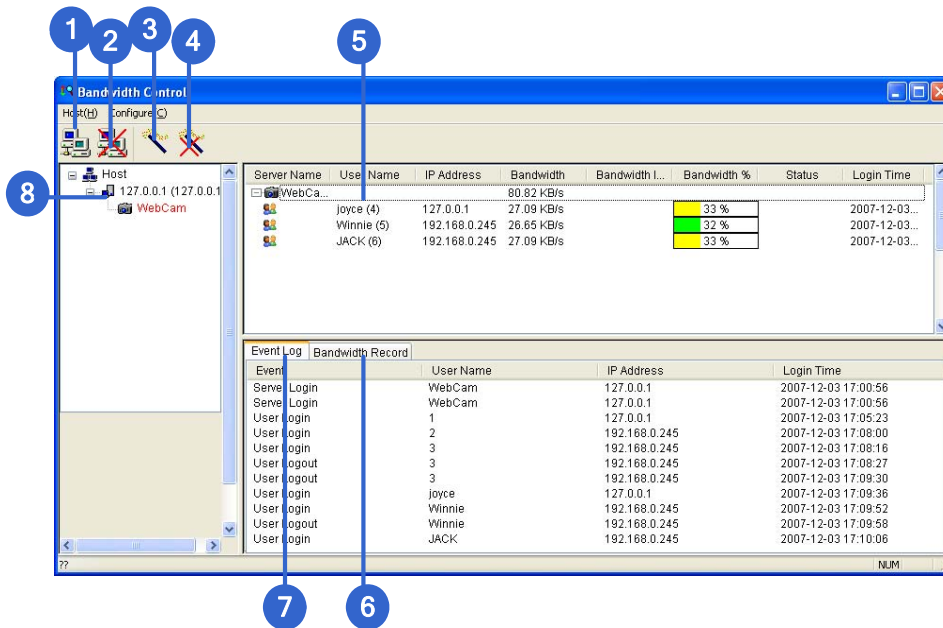





Figure 9-31

No.	Name	Description
1	Connection	Builds the connection to a WebCam server.
2	Disconnect	Stops the connection to a WebCam server.
3	Get Control	Obtains the right to remotely control the WebCam servers.
4	Give Up Control	Ceases controlling the WebCam servers and users.
5	User List	Displays the connected users and their status
6	Bandwidth Record	Displays the network traffic in graph display.
7	Event Log	Records activities of WebCam servers and users.
8	Host List	Displays all WebCam servers to be connected.

9.6.3 Allowing Remote Control

The network traffic of WebCam server can be controlled when the GV-VMS permits the remote control from the Bandwidth Control program by the following steps:

1. On the main screen of GV-VMS, click **Home**  > **Toolbar**  > **Configure**  > **Network**  > **WebCam Server**. This dialog box appears.

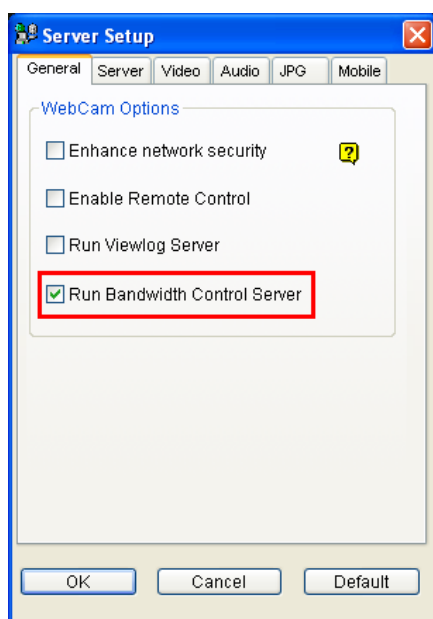

Figure 9-32

2. Under the **General** tab, select **Run Bandwidth Control server**. After this option is enabled, on the Control Center Server option list, the **Bandwidth Control Service** is marked with a check.

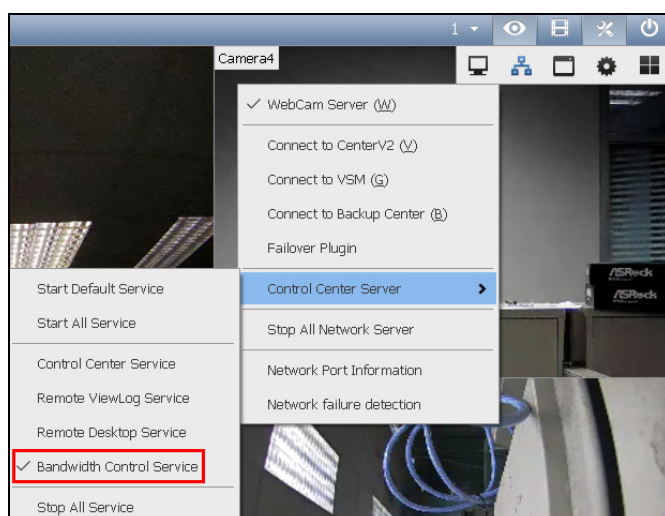

Figure 9-33

9.6.4 Connecting to a WebCam Server

1. Click the **Connection** button (No. 1, Figure 9-31) on the toolbar. This dialog box appears.

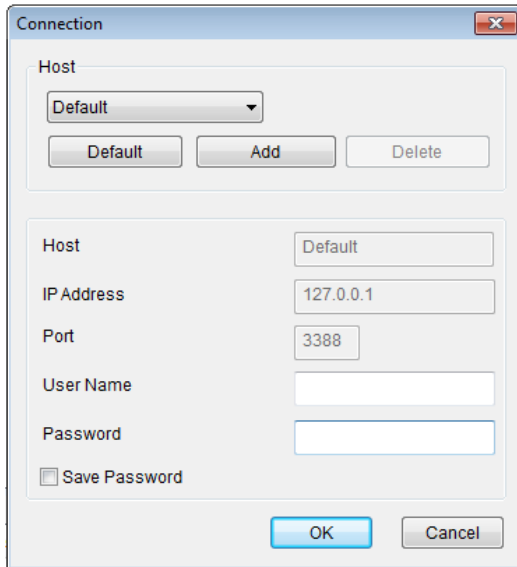

Figure 9-34

2. To add a WebCam server to be connected to, click **Add**.
3. Type the host name, IP address, user name and password of the WebCam server. Modify the port if necessary.
4. Click **OK**. After the connection is established, the WebCam server shows up in the Host List.
5. You can add up to 10 WebCam servers by repeating above steps.
6. To stop the connection, select the host and click the **Disconnect** button (No. 2, Figure 9-31). The host will be deleted from the host list.
7. Up to 5 users of the Bandwidth Control programs can connect to a single WebCam server for network traffic monitoring. However, only one user has the access to bandwidth settings. When this user clicks the **Give Up Control** button (No. 4, Figure 9-31), the user no longer controls the WebCam server. Whoever clicks the **Get Control** button (No. 3, Figure 9-31) first has access to bandwidth settings. For bandwidth settings, see *Controlling a WebCam Server* later in this chapter.

9.6.5 Controlling Specific WebCam Server

To disconnect a login user or set the bandwidth limit for a specific user, right-click the user to have the options below:

Server Na...	User Name	IP Address	Bandwidth	Bandwidt...	Bandwidt...	Status	Login Time
WebC...			736.00 B/s				
	Joyce (4)	192.1...		50 %			2021-04-1...
	Peter (5)	192.1...		50 %			2021-04-1...

Figure 9-35

- **Kick:** Disconnect the user from the WebCam server.
- **Block IP:** Prohibit the user from connecting to the WebCam server. To use the function, the **Enable IP Black List** option (Figure 9-38) must be selected first.
- **Bandwidth Setup:** Select **By Username** to specify a bandwidth limit for the user, or select **By IP** to limit the bandwidth used by the IP address. This setup dialog box will appear. In this example, an IP address is selected for bandwidth limit setup. Select **Bandwidth Setup**, specify a bandwidth limit and click **OK**.

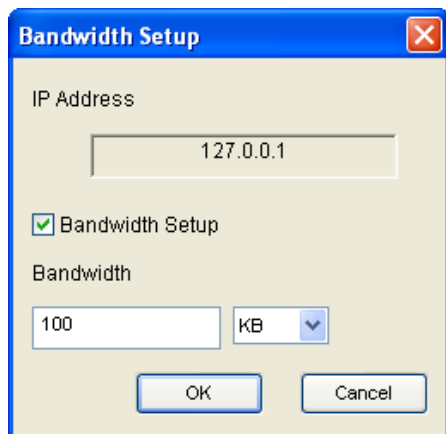

Figure 9-36

9.6.6 Setting up the Bandwidth

You can manage the bandwidth of multiple hosts allocated to a WebCam server by specifying certain users and IP addresses when your network is busy or heavily loaded.

1. Click **Configure** on the menu bar and select **Bandwidth Setup**.
2. In the Bandwidth Setup dialog box, select the desired WebCam server and click **OK**. This dialog box appears.

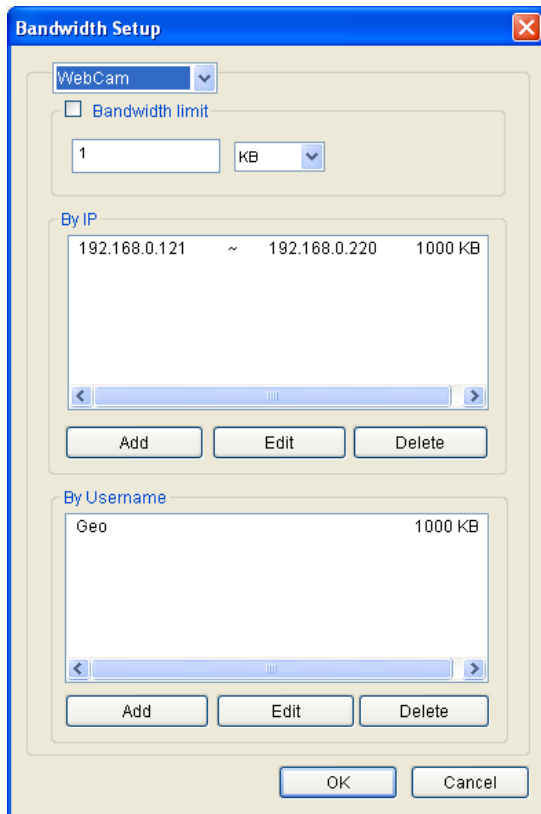

Figure 9-37

- **Bandwidth limit:** Select to define the total bandwidth that the WebCam server will be allowed to use on your network.
- **By IP:** Click **Add** and specify a IP address or a range of IP addresses and its bandwidth limit.
- **By Username:** Click **Add** and specify the user name and its bandwidth limit.

Note: If you have already specified the total bandwidth to a WebCam server, it is prioritized before the bandwidth limits set to user names and IP addresses.

9.6.7 Block List Setup

Two types of block lists are provided to restrict the access to a WebCam server: permitting and denying a specified range of IP address to establish the connection. Note that only one type of block list can be used at a time.

1. Click **Configure** on the menu bar and select **IP White / Black List Setup**. A dialog box prompts for you to select a host.
2. In the IP White / Black List Setup dialog box, select the desired WebCam server and click **OK**. This dialog box appears.

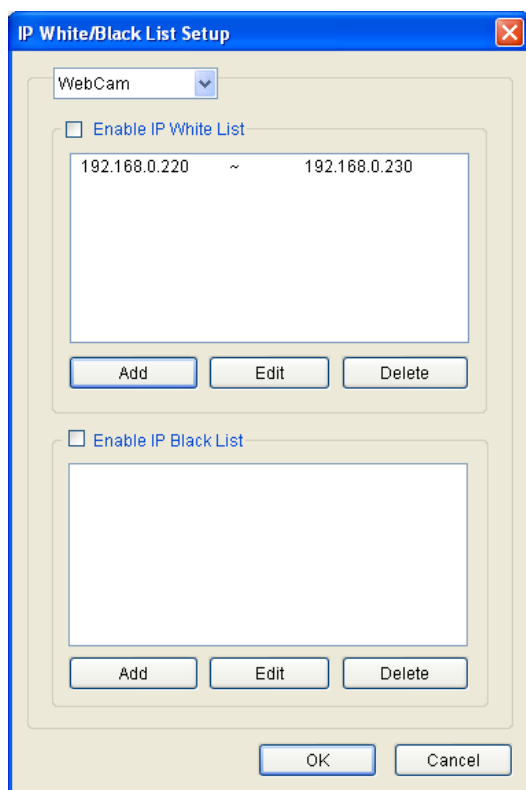

Figure 9-38

3. Select a desired type of block list and click **Add** to define the IP addresses.
 - **Enable IP White list:** Allow the defined range of IP addresses to establish the connection to the WebCam Server.
 - **Enable IP Black list:** Prohibit the defined range of IP addresses from establishing the connection to the WebCam Server.
4. Click **OK** to apply the settings.

9.6.8 General Setup

You can set up sound alarm for user log-in, or change the real-time graph display of network traffic. Click **Configure** on the menu bar and select **General Setup**. This dialog box appears.

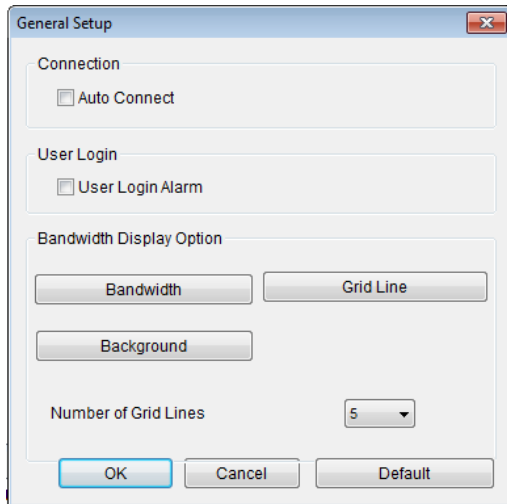

Figure 9-39

- **Auto Connect:** Enable the application to connect to previously connected hosts automatically next time the application restarts,
- **User Login Alarm:** Enable the computer alarm on when a user logs in.
- **Bandwidth Display Option:** Set the color of bandwidth save, grid lines of the graph and the background color of the graph.
- **Number of Grid Line:** Set the number of grid lines to be displayed on the graph.

You can click the Bandwidth Record tab in the Bandwidth Control window to view the network traffic in graph.

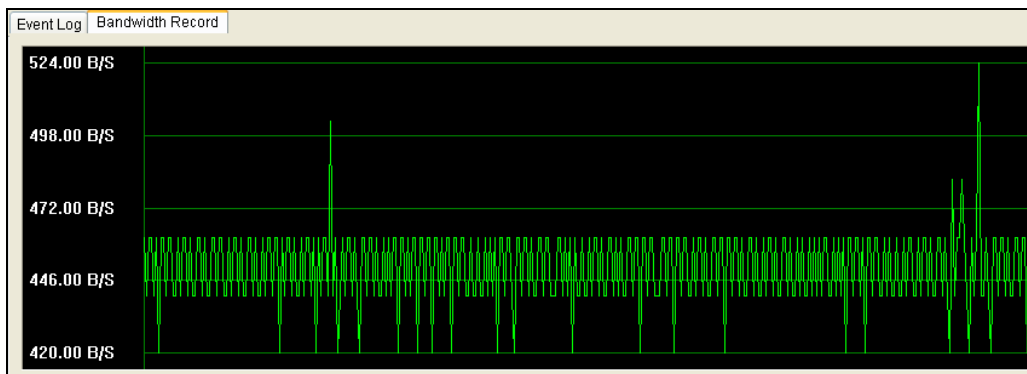

Figure 9-40

9.7 Language Setting

The user interface has been translated from English into 30 other languages. If you find the translation to be unsuitable and would like to correct it, use the **MultiLang Tool** to revise the translation. Next, you can apply the revised text to the applications and export a **MRevise.exe** file to make the same revision on another computer. You can also send the revision back to GeoVision to have the revision included in future software release.

9.7.1 Installing the MultiLang Tool

You can install GV-MultiLang Tool from **Install GeoVision Supplemental Utilities** in the Software DVD or [GeoVision Website](#).

9.7.2 Revising the Translated Text

Revising the Translated Text

1. After completing the installation, close all GeoVision applications, go to **Windows Start > programs > MultilingualConfig**. This dialog box appears.

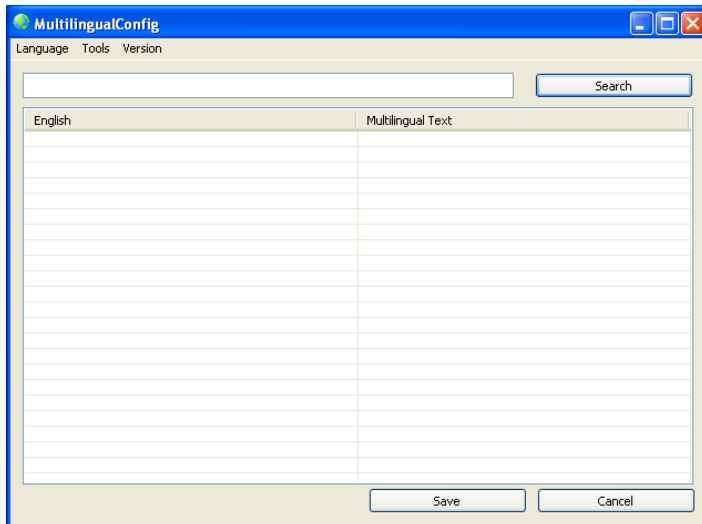

Figure 9-41

2. Click **Language** and select the language of the text you want to revise.
3. Click **Version** to select the version of the GV-VMS that you want to revise.
4. In the **Search** field, type all or part of the text in English or the target language and click **Search**. The results are displayed.

Note: The search is case sensitive.

5. Double-click the text you want to revise. This dialog box appears.

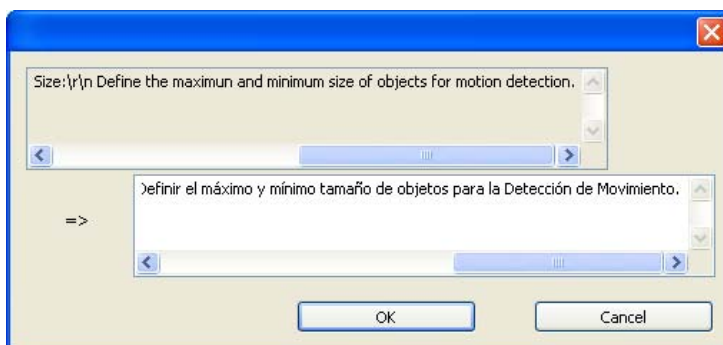

Figure 9-42

6. Revise the translated text and click **OK**.

Note:

1. It is recommended to revise an entire sentence at a time instead of simply searching a single word and replacing the word in all other strings.
 2. The text may contain symbols such as **%d** or **\n** that instruct the application to perform certain functions. Be careful not to change the symbols in the translated text.
 3. Before making any revision, click **Tools** and select **Revision Note** to read the revision instructions.
-

Applying the Revised Text

1. To apply the revised translation to the applications, click **Save**. This dialog box appears.

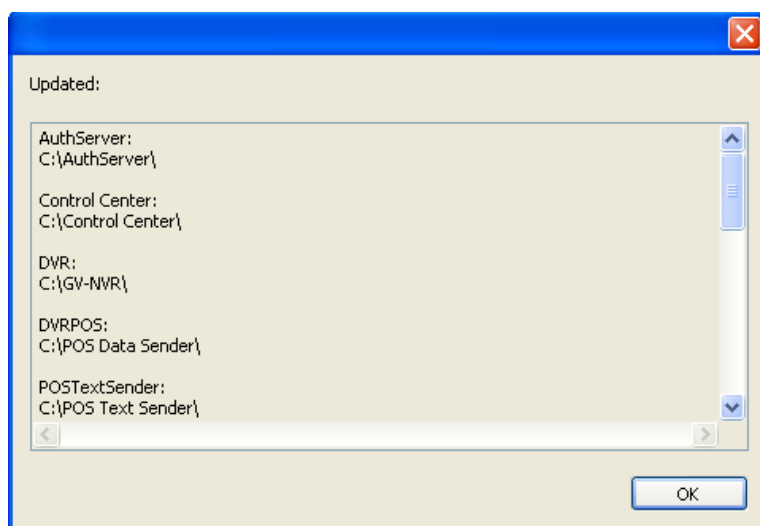

Figure 9-43

Note: The system will automatically locate the corresponding files on your computer and replace with the revised translation for the following applications: GV-VMS, Authentication Server, Bandwidth Control Client Site, Center V2, Dispatch Server, Fast Backup and Restore (FBR), GV-IP Device Utility, MCamCtrl Utility, Remote E-Map and Remote ViewLog.

2. Click **OK**. The message *“Do you want to apply the revised multilingual texts to another folder?”* appears. If the storage path for the application has been changed or if the associated application is not listed in the dialog box, click **Yes** and select the folder of the application.

Exporting the Revised Text

1. To export the revision as an executable file, click **Tools > Export > Export executable file**. You can copy the .exe file to another computer and apply the same translation revision by running the .exe file.
2. To report the translation revision back to GeoVision:
 - If your default mail client is Outlook, Outlook Express or Mozilla Thunderbird, click **Tools, Export** and **Send Report** to send the revision.
 - If your default mail client is not set up or supported, click **Tools, Export** and **Export text file**, and email the exported text file to gvlocalize@geovision.com.tw.
3. For the distributors to duplicate Software DVD with the translation revision,
 - Copy and paste all the contents of Software DVD to your computer.
 - Export the revised translation file and rename the file as **MRevise.exe**.
 - Move **MRevise.exe** to the location you saved the contents of Software DVD :**\Software\Translation Revision**.
 - Duplicate the Software DVD with the **MRevise.exe** file.
 - Test the Software DVD by clicking **10. Import Translation Revision** from the Install Program window to apply the translation revision.

9.7.3 Setting the UI Language to English

The default user interface (UI) language of the following GeoVision software and applications is set according to the region detected. You can install the **Set Language** tool to set the UI language to English.

- GV-VMS
- GV-Fast Backup and Restore Multicam System
- ViewLog
- GV-Remote ViewLog
- GV-IP Device Utility
- GV-Center V2
- GV-Dispatch Server
- GV-Control Center
- GV-Remote E-Map

You can install **GV-Set Language** tool from **Install GeoVision Supplemental Utilities** in the Software DVD or [GeoVision Website](#).

- 1.
1. In the Configure window, select **English** from the Language drop-down list.

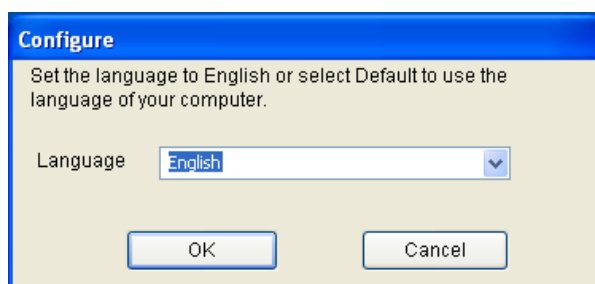

Figure 9-44

2. Click **OK** and restart your GeoVision software or application to enable the English UI.

9.8 GV-SD Card Sync Utility

The GV-SD Card Sync Utility allows you to download videos from the Micro SD card inserted in the GV-IP Camera. When the connection between the GV-IP Camera and the GV-VMS is lost, recordings are automatically saved to the memory cards inserted in the GV-IP Cameras. To automatically synchronize and download recordings from the micro SD cards to a local folder, install and execute the program on the GV-VMS.

Note:

1. GV-SD Sync Card Utility is only supported by GV-IPCam H.264 V1.11 or later, GV-IPCam H.265 V1.00 or later, GV-BX2600 V1.00 or later, GV-PPTZ7300 V1.01 or later, and GV-SD2411 / BX12201 / FER12203 V1.01 or later.
 2. It is recommended to keep the GV-SD Card Sync Utility running in the background to automatically synchronize and download videos.
-

9.8.1 Installing GV-SD Card Sync Utility

You can install **GV-SD Card Sync Utility** from **Install GeoVision Supplemental Utilities** in the Software DVD or [GeoVision Website](#).

9.8.2 Setting up GV-SD Card Sync Utility

1. Run the **GV-SD Card Sync Utility**. The main window and the Setting window appear. The Setting window pops up automatically upon first execution. Otherwise, click the **Setting** button  on the main window.

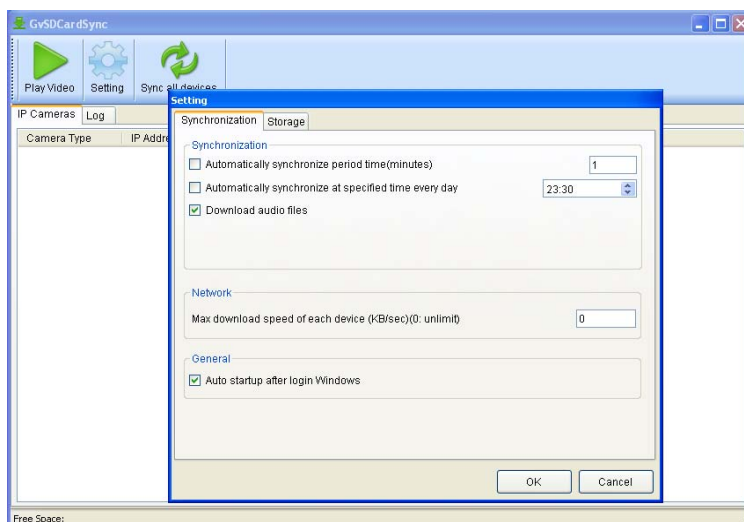

Figure 9-45

2. To configure synchronization, network and startup settings, select the **Synchronization** tab on the Setting window. This page appears.

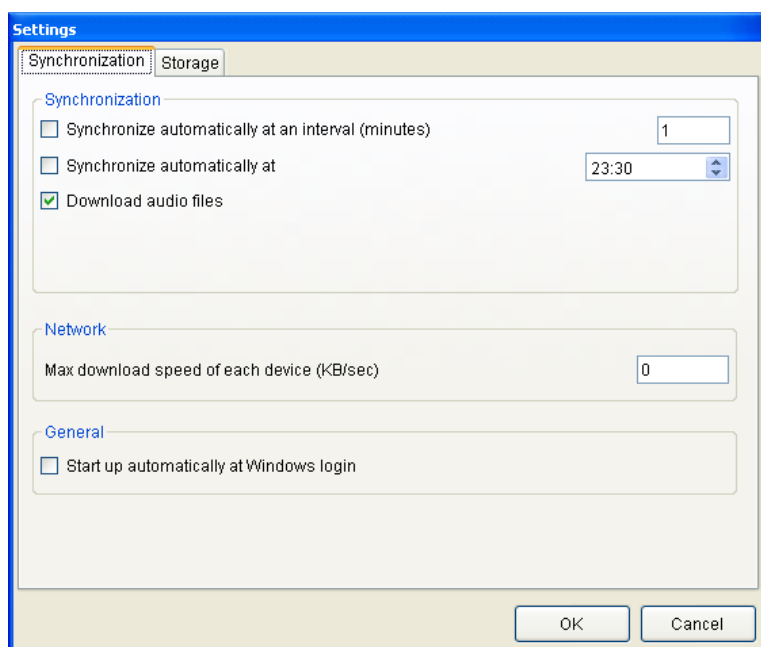

Figure 9-46

[Synchronization]

- **Synchronize automatically at an interval:** Automatically synchronize videos from micro SD cards to a local folder at the specified interval.
- **Synchronize automatically at:** Automatically synchronize videos from micro SD cards to a local folder at the specified time.
- **Download Audio Files:** Download audio files along with the video files. This option is enabled by default.

[Network]

- **Max. download speed of each device (Kb/sec):** To make sure the bandwidth is not completely taken up while downloading files from the memory card, specify a maximum download speed. If you do not want to set a bandwidth limit, type **0**.

[General]

- **Start up automatically at Windows login:** Automatically launch GV-SD Card Sync Utility when Windows starts up.

3. To configure the storage and recycling settings, select the **Storage** tab on the Setting window. This page appears.

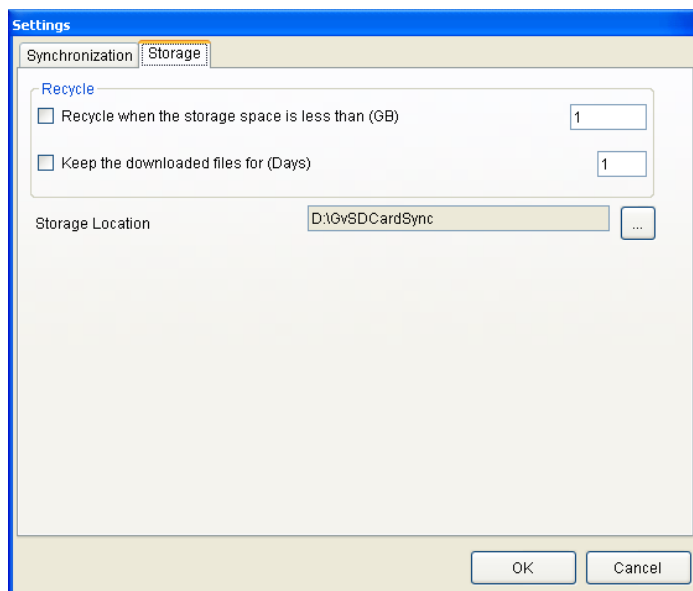

Figure 9-47

Note: By default, downloads are saved to **:\GvSDCardSync** and are not recycled automatically.

[Recycle]

- **Recycle when the storage space is less than (GB):** Specify a minimum free space of your local storage for file recycling.
- **Keep the downloaded files for (Days):** Specify the number of days to keep the download files at the local hard drive.
-

[Storage Location]

To configure the storage path, click the button next to the location field and specify a storage location.

4. Click **OK** to save the configuration and exit the Setting window.

9.8.3 The Main Window

After installing GV-SD Card Sync Utility, point to **Start > Programs > GV-SDCardSync > click**

 to launch the program. This window appears.

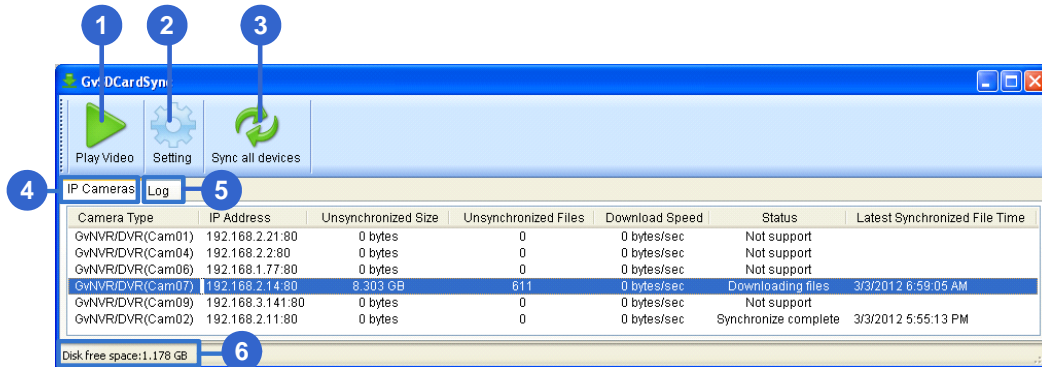

Figure 9-48

No.	Name	Description
1	Play Video	Plays downloaded recordings of the selected GV-IP Cameras using the ViewLog player. For details, see <i>Chapter 4 Video Playback</i> .
2	Setting	Configures settings of synchronization, network, storage location and recycling criteria. See <i>Running the GV-SD Card Sync Utility</i> earlier in this chapter.
3	Sync all devices	Manually synchronizes and downloads the recording files saved in GV-IP Camera.
4	IP Camera Tab	Shows information of GV-IP Camera connected to the GV-VMS,.
5	Log Tab	Displays up to 100 event entries of the GV-SD Card Sync Utility. Once the entries are full, recycling will start from the oldest file.
6	Storage Space	Shows the storage space of the designated hard drive.

Note:

1. The synchronization time is recorded according to the system time of the GV-IP Camera.
2. The logs are deleted once the GV-SD Card Sync Utility is re-activated.

9.9 The Media Man Tools Window

The program Media Man Tools provides a hot-swap feature, allowing a non-stop recording. You can add and remove a hot-swap or portable hard drive to the GV-VMS without interrupting the monitoring. When the new drive is added, it will be configured to the recording path automatically.

Additionally, you can back up ViewLog player and database files to play back at any computer.

Note: The minimum disk capacity for hot-swap feature is 32 GB.

9.9.1 The Media Man Tools Window

This program comes with the installation of GV-VMS. Click **Drive C** in My Computer, select the GV-VMS folder, and then select the **Media Man Tools**. This window will appear.

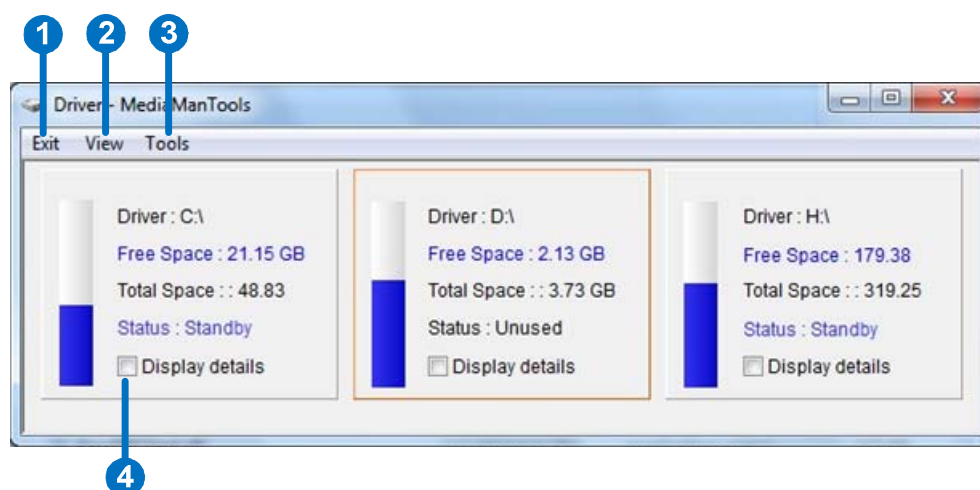

Figure 9-49

No.	Name	Description
1	Exit	Closes or minimizes the Media Man Tools window.
2	View	Refreshes the disk drive status shown in this window.
3	Tools	Sets up the LED panel and automatically logs in the Media Man Tools window.
4	Display Details	Select the option to view the status and information of the disk drives. For details, see <i>Viewing Disk Drive Status</i> later in this section.

9.9.2 Viewing Disk Drive Status

To view the detailed information of a drive, check **Display Details** (No. 4, Figure 9-49) in the desired drive section. The status window will appear.

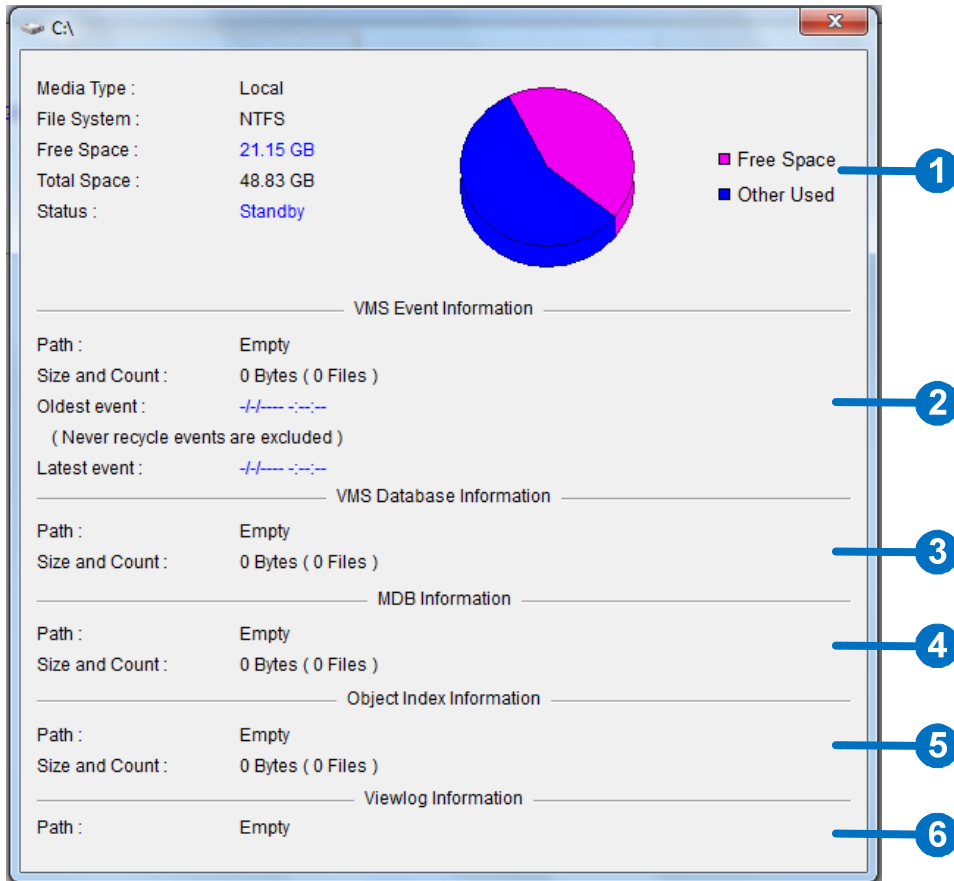

Figure 9-50

No.	Name	Description
1	Disk Properties	<p>Indicates disk information.</p> <p>In "Media Type," two messages may appear:</p> <ul style="list-style-type: none"> ● LAN: indicates a network hard drive is connected. ● Local: indicates a local hard drive is connected. <p>In "Status", three messages may appear:</p> <ul style="list-style-type: none"> ● Standby: indicates the hard drive already specified as the recording path. ● Unused: indicates the hard drive not specified as the recording path. ● Recording: indicates the files are being recorded to the disk.

No.	Name	Description
2	VMS Event Info	Indicates the path, size and number of recorded events; the dates of the oldest and latest events.
3	VMS Database Info	Indicates the path, size and number of the ViewLog Event List log files.
4	MDB Info	Indicates the path, size and number of System Log files.
5	Object Index Info	Indicates the path, size and number of Object Index files.
6	ViewLog Info	Indicates the location you have backed up the EZ ViewLog player.

Note: The VMS Event Info updates every minute. The MDB Info, VMS Database Info, Object Index Info and ViewLog Info update as data changes.

9.9.3 Adding a Disk Drive

1. Click **Drive C** in My Computer, select the GV-VMS folder, and select the **Media Man Tools**.
2. Insert a hot-swap hard drive or plug a portable hard drive to your computer. This dialog box appears.

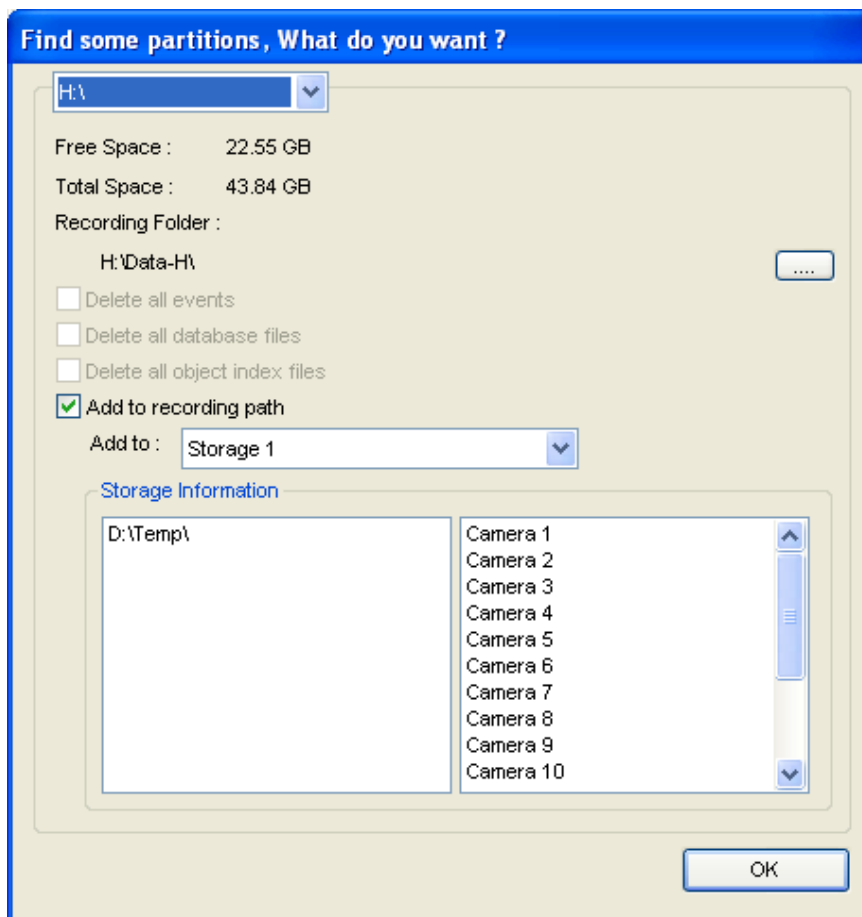

Figure 9-51

3. Select **Add to recording path** and select the storage group from the drop-down list.
4. If there are recording files saved on the hard drive, you may select the options of **Delete all events**, **Delete all database files** or **Delete all object index files**.
5. Click **OK** to automatically configure the hard drive to the recording path.

To verify the hard drive is added successfully, check if the “Status” of the drive displays *Standby* (see Figure 9-49).

Tip: To add a local drive to the recording path, right-click the desired drive on the Media Man Tools window (Figure 9-49) and select **Add for recording**.

9.9.4 Removing a Disk Drive

To remove a disk drive from the recording path, right-click the desired drive on the Media Man Tools window (Figure 9-49), and select **Remove from recording path**. This dialog box will appear. You can export related database files with the recordings on the hard drive. You can also export the ViewLog player which allows you to play back the recordings on any computer.

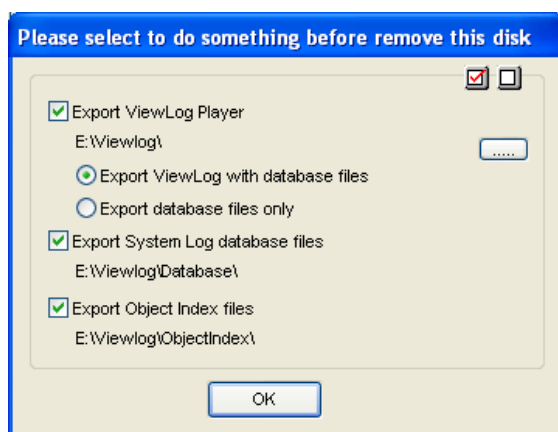

Figure 9-52

- **Export ViewLog Player:**
 - ⊙ **Export ViewLog with database files:** Exports the ViewLog player together with ViewLog Event List log files (.db files), related to the recordings on the hard drive.
 - ⊙ **Export database files only:** Exports ViewLog Event List log files (.db files) only if the ViewLog program already exists on the hard drive.
- **Export System Log database files:** Exports the system log files (.mdb files), related to the recordings on the hard drive.
- **Export Object Index files:** Exports the Object Index files, related to the recordings on the hard drive.
- **[...] button:** If you want to change the default folder “Viewlog” created on the hard drive, click the button.

Note: Removing the hard drive will affect ViewLog database. To restore these events, add the hard drive back to the system and run **Repair Database Utility**.

9.9.5 Logging in Automatically at Startup

To automatically log in and minimize the Media Man Tools window at Windows startup, follow these steps:

1. Click **Tools** on the menu bar, and select **Auto login at Windows startup**. A dialog box appears.
2. Type the ID and password of the GV-VMS for automatic login in the future.
3. If you want to minimize the Media Man Tools window to the system tray at startup, select **Auto minimize at startup**.
4. Click **OK**.

9.9.6 Setting LED Panel

A LED panel on the screen provides a quick indication of the activity status of hard disk drives.



Figure 9-53

LED Color	Description
Gray	No HDD is assigned to this LED.
Green	A HDD is assigned to this LED.
Red	The HDD is full.
Flashing Green	GV-VMS is recording or the video / audio files are played back in ViewLog.
Flashing Red	The HDD is recycling.

1. Click **Tools** on the menu bar on the Media Man Tools window, and select **Setup LED Panel**. This dialog box appears.

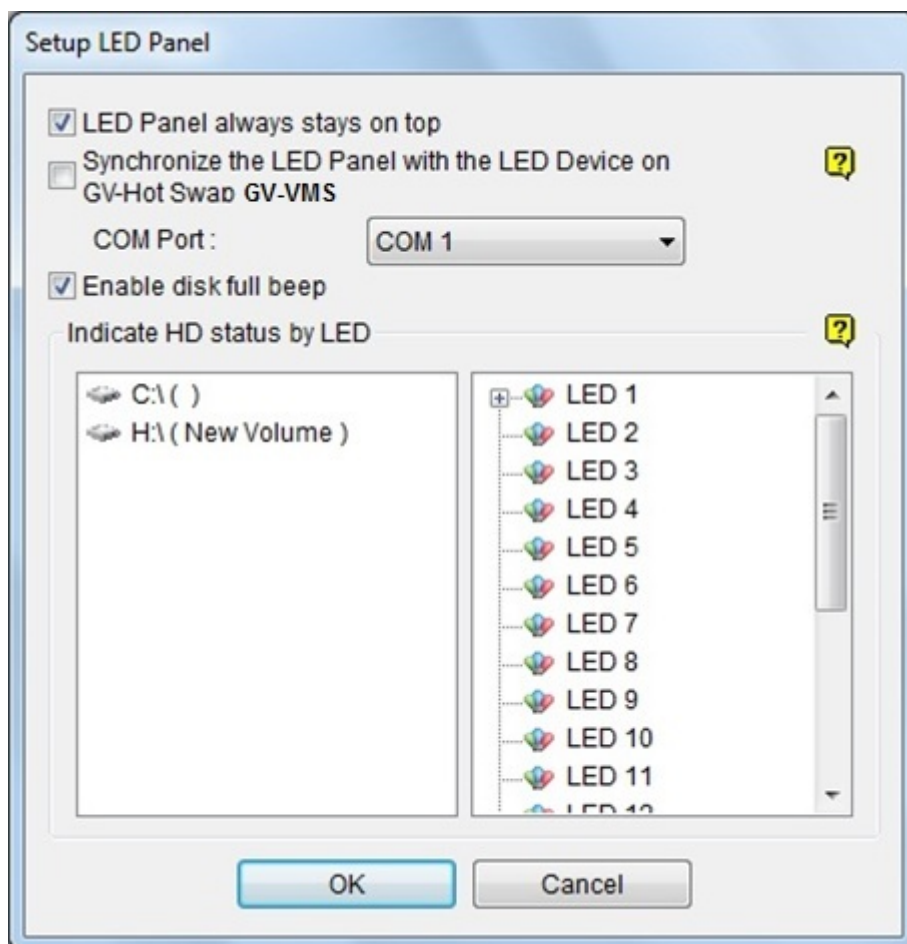

Figure 9-54

- **LED Panel always stays on top:** Makes the LED panel stay on top of other windows when the Media Man Tools window is minimized.
 - **Synchronize the LED Panel with the LED Device on GV-Hot Swap VMS:** For GV-Hot Swap VMS System only. If enabled, the LED device installed on the front panel of the GV-Hot Swap VMS System will synchronize with the LED panel on the screen.
 - **Enable disk full beep:** When the hard disk drive is full, the system makes the beeping sound. Note this function only works when the motherboard is equipped or installed with a PC speaker.
2. By default, only the hard disk drive that stores video and audio files will be assigned to LED. If you want to re-assign the hard disk drive or assign other drives to LEDs, freely move the hard disk drive to the desired LED on the tree.
 3. Click **OK** to apply the settings, and minimize the Media Man Tools window to display the LED panel on the screen.

4. If you want to return to the Media Man Tools window, right-click the LED panel and select **Switch to the setup window**.

Note:

1. Because the LEDs are designed to indicate the video and audio files are being written or read, it is not recommended to assign the HDDs that store log files to the LEDs.
 2. If the HDD that stores log files is assigned to a LED and its LED turns red, make sure the log files are not being written before you remove it. Otherwise, the log files might be lost during the removal. The default location for data storage is D:\Record\
-

9.10 Alert Notifications through SNMP Protocol

You can send alert notifications to SNMP-compatible software by using the SNMP Trap Notification utility.

1. Click Windows' **Start** > **All Programs** > the **GV-VMS** folder > **SNMPTrapNotification.exe**. This dialog box appears.

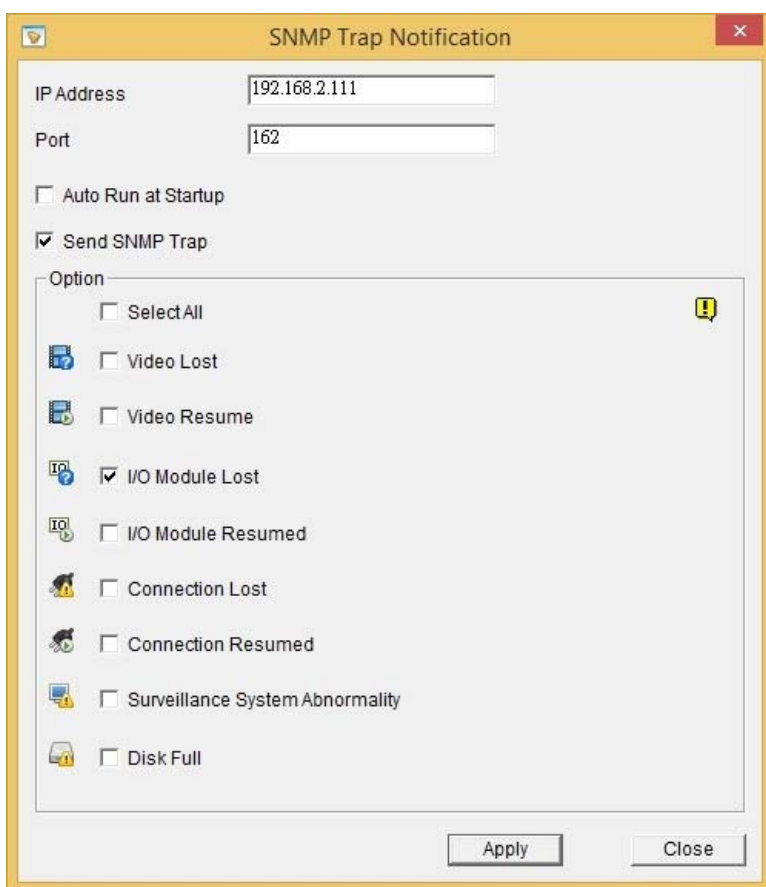

Figure 9-55

2. Type the **IP address** of the software that will be receiving the alert notification, and modify the **Port** if needed.
3. To run SNMP Trap Notification upon system startup, select **Auto Run at Startup**.
4. Select **Send SNMP Trap** to enable the function.
5. Under Option, select the types of notifications you want to send to the software.
6. Click **Apply**.

9.11 Local and Remote Backup

GV-VMS can back up recorded files to any connected hard disk drives or GV-Backup Center over the Internet. A copy of recorded files will automatically be backed up to the assigned path or GV-Backup Center.

Note: You can only choose either **Local Backup** or **Remote Backup** (with GV-Backup Center). The two backup methods can not be applied at the same time.

9.11.1 Remote Backup

To back up with GV-Backup Center, see 3.4 *Connecting GV-VMS* in [GV-Backup Center User's Manual](#).

9.11.2 Local Backup

To connect to a hard disk drive, follow the steps below:

1. Click **Home**  > **Toolbar**  > **Network**  < **Backup Center**. The Backup Server dialog box appears.

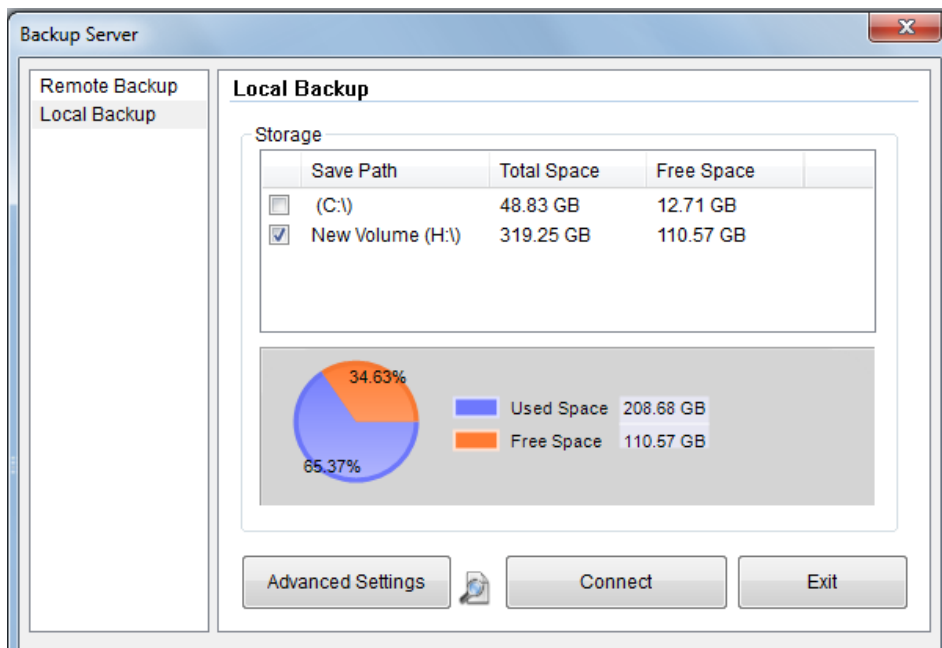

Figure 9-56

2. Select **Local Backup** in the left panel.
3. Specify in which hard drive you want to back up your files. If you assign multiple hard drives, when the first hard drive is full, the files will be backed up to the second hard drive.
4. For **Advanced Settings**, see the later section for details.
5. To configure file backup schedule and transfer time, see *9.11.3.2 File Transfer Setting for Local Backup*.
6. Select your desired storage path and select **Connect** to back up files.
7. On the Windows taskbar, right-click on the **Geo Backup Client** icon. Three options are available:



Figure 9-57

- **Status:** “Connected” indicates that Local Backup is successfully activated.
- **Backup Status:** indicates the status of file backup.
- **Playback:** open ViewLog player for playback.

File Name	Camera Name	Progress	Status	Speed
Event20170208163116003.Avi	Camera3	<div style="width: 100%; height: 10px; background-color: green;"></div>	File Transfer OK	73208.11 KB/...

Figure 9-58

Note:

1. You can also click on the first setting page of Local Backup to open ViewLog player.
2. Be sure to assign different Local Backup storage paths from those of GV-VMS.

9.11.3 Advanced Settings

9.11.3.1 Advanced Settings for Local Backup

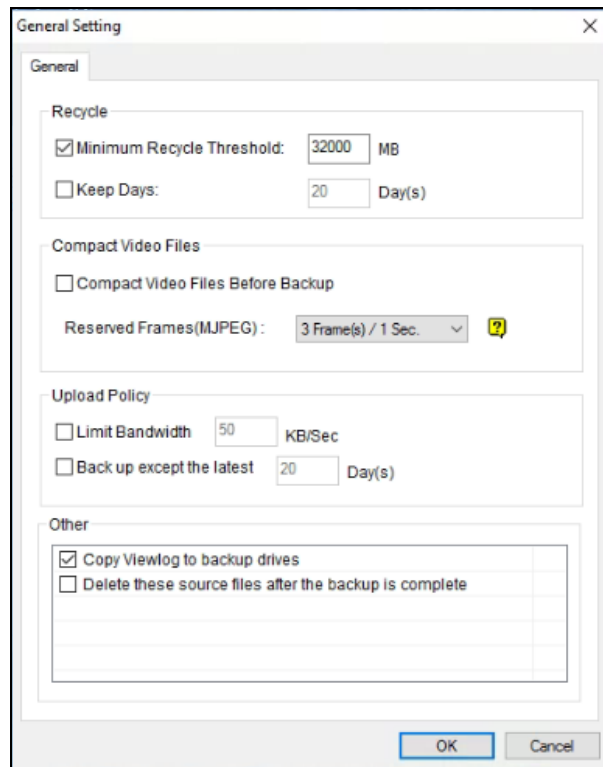

Figure 9-59

- **Minimum Recycle Threshold:** Specify a minimum free space of your local storage for file recycling.
- **Keep Days:** Specify the number of days to keep the download files at the local hard drive.
- **Compact Video Files Before Backup:** Compact the recorded video files before backing up.
 - If the recorded video is compressed with H.265 or H.264 codec, it will be compacted into key frames only.
 - If the recorded video is compressed with MJPEG codec, you can use the **Reserved Frames (MJPEG)** option to specify the number of frames.
- **Limit Bandwidth xx KB/Sec:** Specify a bandwidth limit when uploading files.
- **Back up except the latest xx Day(s):** Specify to exclude the latest number of days during backup.
- **Copy Viewlog to backup drives:** Copy ViewLog player to the assigned backup drives.
- **Delete these source files after the backup is complete:** Delete the recorded files in GV-VMS after the files are successfully backed up.

9.11.3.2 File Transfer Settings for Local Backup

The File Transfer Setting allows you to specify the recordings to back up and transfer time.

In this setting dialog box, you can define the following backup rules:

- The day of recordings to be transferred.
- The time period of recordings to be transferred.
- The type of recordings to be transferred, including motion detection, I/O trigger or all types of events.
- The time to back up the files.

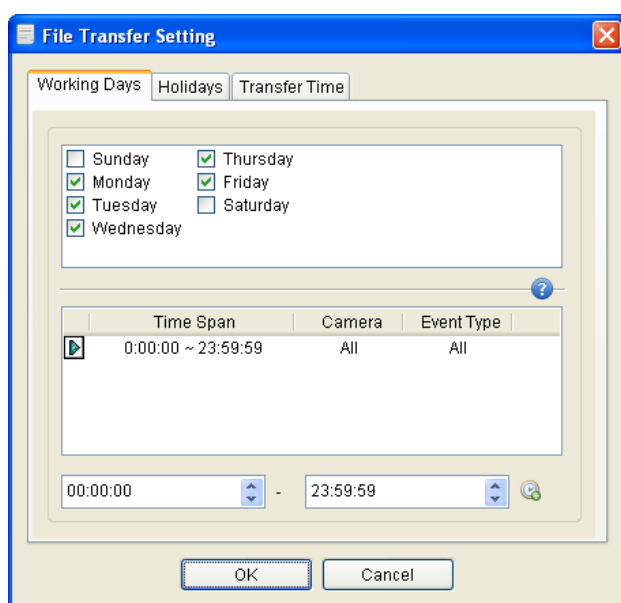

Figure 9-60

[Working Days] Define up to 10 backup rules to specify which recordings, including which type, which time period and on which working days they were recorded to be transferred to the assigned hard disk drive.

1. Select the day, including Monday to Sunday.
2. Click the arrow button before Time Span and select **Modify**.

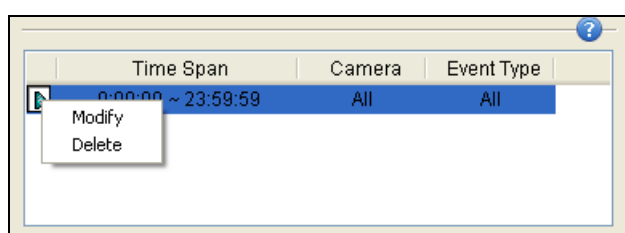

Figure 9-61

- In this dialog box, select the **Camera** that you want to back up its recordings, specify **Time Span** in which time period of recordings to be transferred, and select **Events** that you want to back up all event files, Motion or I/O trigger events only.

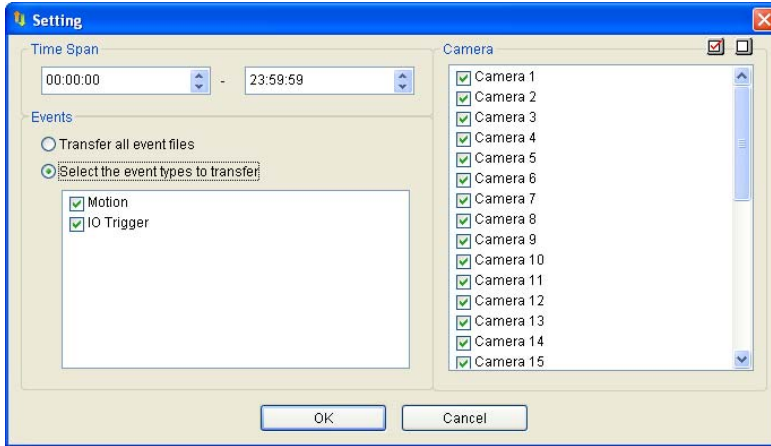



Figure 9-62

- Click **OK**. The backup settings are created.
- To define another backup rule, click the  button. A new Time Span is created.

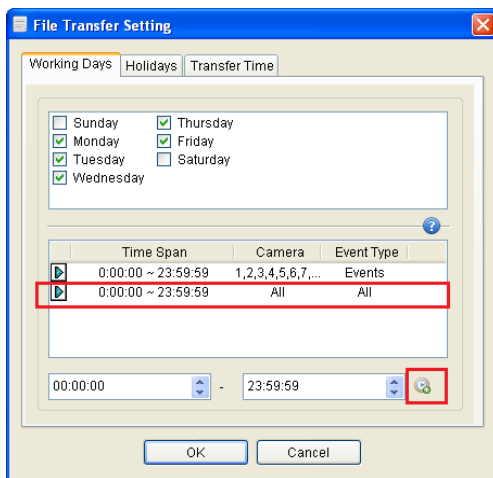

Figure 9-63

- Click the arrow button, select **Modify** and follow the step 3 to define the backup rule.

[Holidays] Define up to 10 backup rules for non-working days, which include which non-working day, which camera and which type of recording to be transferred to the assigned hard disk drive. For how to set up a rule, see the instructions in the above **[Working Days]**.

[Transfer Time] Define the daily time, from 00:00 to 23:59:59, to back up the files from the hosts to the assigned hard disk drive.

9.12 Report Generator

Only available on GV-VMS V18.1 or later, Report Generator is a useful utility that allows users to generate daily and/or weekly reports, in MDB or HTML format, for the recording data of GV-VMS without requiring additional installation.

For details, see [Report Generator User's Guide](#).

9.13 GV-Cloud Center

You can search events of GV-VMS with the cloud-based service, GV-Cloud Center. Using **myGVcloud NotifyApp**, you can receive notifications, look up events, access live view and play back recordings from any iOS or Android mobile devices. Without installing any software, you can also log onto **GV-Cloud Center Portal** from a Web browser on any PC to access GV-Cloud Center for event search and playback. Refer to [GV-Cloud Center User's Manual](#) for details on GV-Cloud Center.

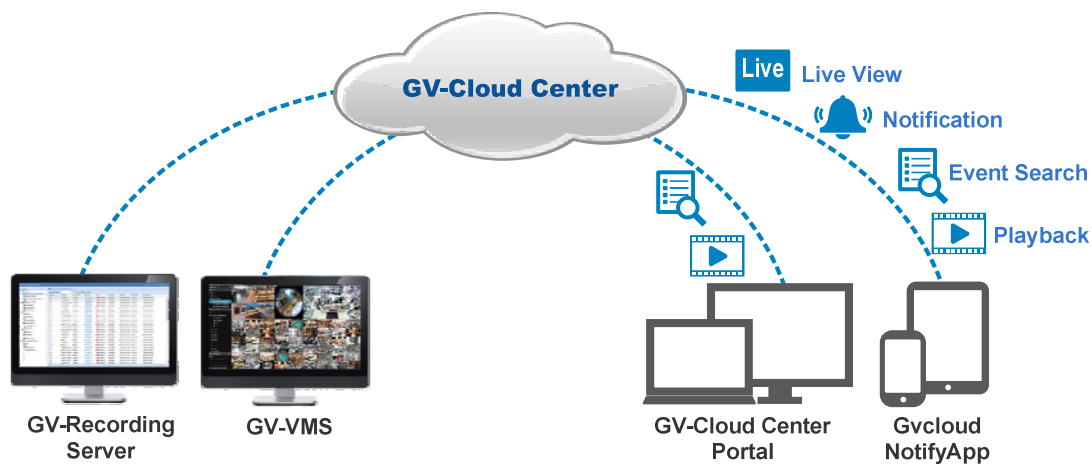

Figure 9-64

Chapter 10

Point-Of-Sale (POS) Application	345
10.1 Setting up Text Overlay	346
10.2 Filtering Transactions for a Particular item.....	347
10.3 Triggering Transaction Alarms.....	349
10.4 Mapping Codepage.....	351
10.5 Coloring Transactions of a Particular Item.....	352
10.6 Seeing the Receipt Details of a Particular Transaction ...	355
10.7 Filtering Transactions by a Keyword	361
10.8 Searching for and Playing back POS Events.....	364

Point-Of-Sale (POS) Application

A POS device can be integrated to the GV-VMS with transaction data overlaid on video channels. Transaction alerts can be triggered to notify you of transaction events. Video searches can be performed based on a specific transaction item or a specified time period.

GeoVision provides three POS integration solutions to meet a variety of needs.

1. Direct POS Integration
2. GV-Data Capture Box Integration
3. Graphic Mode POS Integration

Please check the [flowchart](#) to find out which solution is suitable for you.

10.1 Setting up Text Overlay

To change the text font and position of the transaction data on the live view and recorded files, click the **Text Setup** button on the POS Server Setup dialog box (**Home > Toolbar > Configure > System Configure > Accessories > POS Device Setup > select one POS device on the list > click the Modify button**).

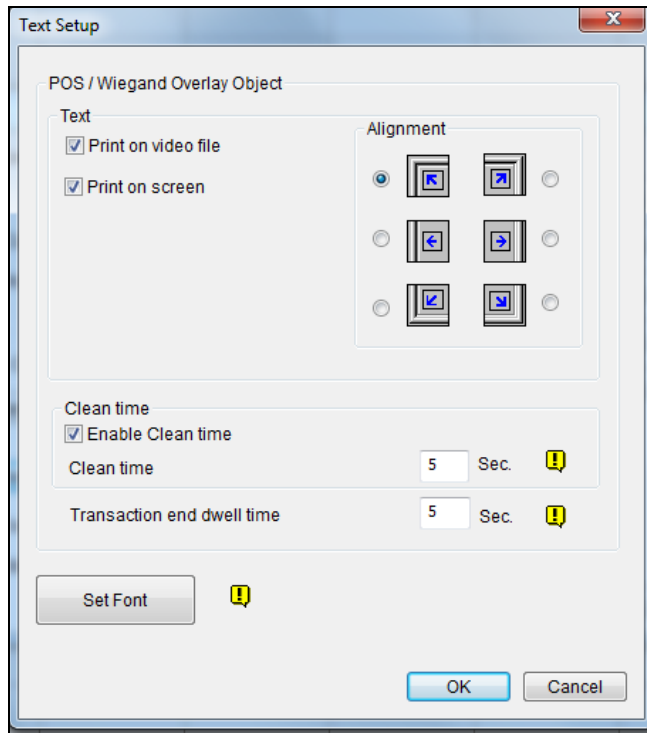

Figure 10-1

[Text]

- **Print on video file:** Displays POS data on the recorded video file.
- **Print on screen:** Displays POS data on the transaction scene.
- **Alignment:** Select the position of text overlay on the screen.

[Clean Time]

- **Clean time:** Specify the amount of time in seconds after which GV-VMS has not received the transaction data from the POS device, i.e. the cashier stops entering the transaction data. The already-displayed POS data will be hidden from the live view.
- **Transaction end dwell time:** Specify the amount of time in seconds that POS data stays on the live view before the next transaction.

[Set Font] Click the **Set Font** button to set up the font for POS data.

10.2 Filtering Transactions for a Particular item

POS Field Filter allows you to create an independent column for a transaction item in System Log. The feature filters the transactions, and highlight the price of the item under the created column.

For this example, the transaction item is “Golden Pineapple” which transaction data stands out in the System Log to gain your attention.

Time	Event	Content	Camera	coke	Total	Golden Pineapple	Note
2/15/2017 17:54:48		* Apple Juice \$0.99	Camera...				
2/15/2017 17:54:52		* Papaya \$1.00	Camera...				
2/15/2017 17:54:56		* Strawberry \$5.99	Camera...				
2/15/2017 17:55:00		* Peach \$3.99	Camera...				
2/15/2017 17:55:04		Reg 4889 5 Item	Camera...				
2/15/2017 17:55:08		Total \$12.96	Camera...		12.96		
2/15/2017 17:55:12		Cash \$20.00	Camera...				
2/15/2017 17:55:16	Cash Drawer open	Change\$17.04	Camera...				
2/15/2017 17:55:21		* All Natural Creamline milk \$1.78	Camera...				
2/15/2017 17:55:25		* Golden Pineapple \$3.99	Camera...			3.99	
2/15/2017 17:55:29		* Ben Jerry Ice Cream \$3.00	Camera...				
2/15/2017 17:55:33		* Doritos Chips \$1.78	Camera...				
2/15/2017 17:55:37		Reg 4888 4 Item	Camera...				
2/15/2017 17:55:41		Total \$12.35	Camera...		12.35		

Figure 10-2

To set up the function, follow the steps below:

1. On the POS Server Setup dialog box, select a desired POS device, and select **Capture Data Setting**. The POS Capture Data Setting dialog box appears.

Device	Mapping Camera	Parameter 1	Parameter 2	POS Module
POS 2	Camera 2	127.0.0.1	TCP/IP Port=4000	POSTextSender
POS 23	Camera 1	127.0.0.1	TCP/IP Port=4001	POSTextSender

Name	Type	Key Word

Figure 10-3

2. Select a desired POS device from the drop-down list for setup.
3. Click the **New** button and select **Caption Data**. This dialog box appears.

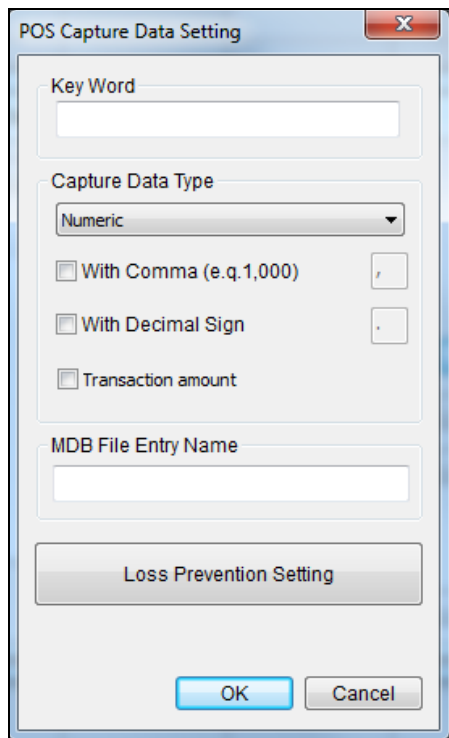

Figure 10-4

[Key Word] Type a keyword matching exactly a transaction item in the receipt. The field is case sensitive.

[Capture Data Type] Select the type of data followed by the specific transaction item: **Numeric**, **Currency** or **Text**. If the transaction item is followed by a price amount, select **Numeric** or **Currency**. If it is followed by alphabets, select **Text**. Any defined amount or text after the keyword will be brought out.

- **With Comma:** If there are commas in a price amount, e.g. \$1,000, select the option.
- **With Decimal Sign:** If there are decimal signs in a price amount, e.g. \$10.5, select the option.
- **With Space:** The option is only available when you select **Text**. If there is space among letters, select the option.

[MDB File Entry Name] Name the file to store the data.

4. Click **OK**.
5. Open the POS Table (**ViewLog > Toolbar > Tools > System Log**) to see the filtering results.

10.3 Triggering Transaction Alarms

When an abnormal transaction amount of a particular item occurs, this function can automatically activate the output device and send out E-Mail alerts. To set up this function, follow these steps:

1. Follow the steps in *Filtering Transactions for a Particular item* earlier in this chapter to define a transaction item first. Note that for this alarm function, a space between letters for the Keyword is not allowed.
2. Click the **Loss Prevention Setting** button. This dialog box appears.

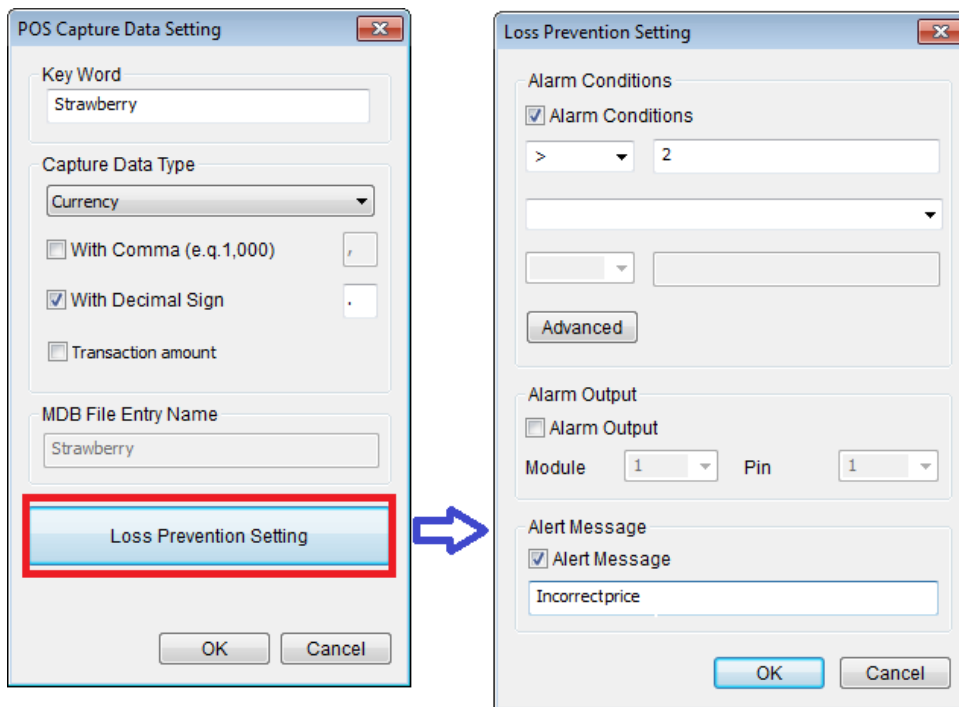

Figure 10-5

[Alarm Conditions] Define the price range for an alarm condition. For this example, when the price amount in a transaction is *great than* (>) than 2 dollars, the assigned alarm output and e-mail alert will be activated.

[Advanced button] See Step 3 below to define the alarm frequency.

[Alarm Output] Assign an installed output module. When the defined alarm condition is met, the output alarm will be triggered.

[Alert Message] Type an alert message (the space between letters is not allowed). When the defined alarm condition is met, the e-mail alert will be sent. To enable e-mail notification, see *Setting up Email Notification* in Chapter 1. And the alert message will also be noted in the System Log.

- To eliminate false alarms, configure alarm frequency.

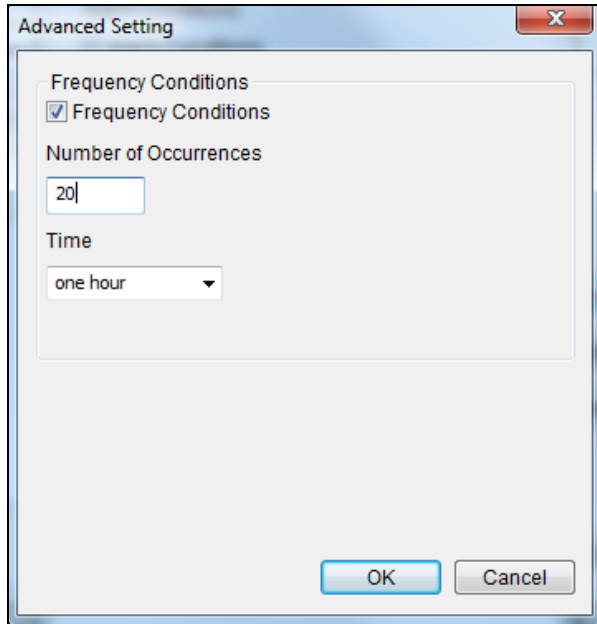
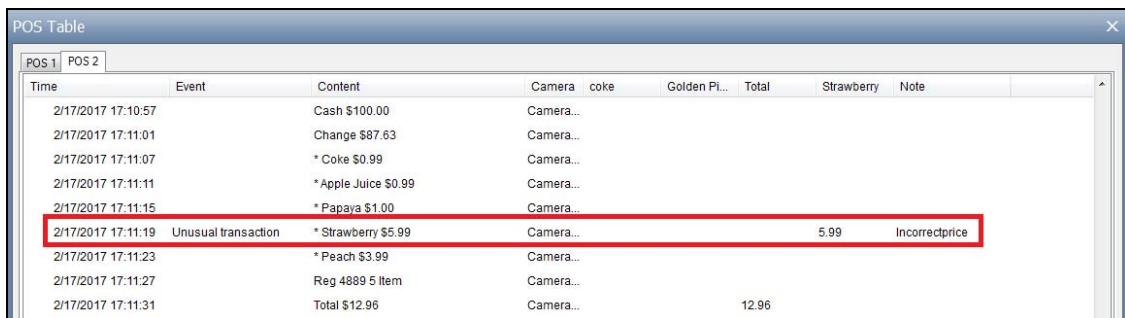

Figure 10-6

- **Frequency Condition:** Enable to set up the number of event occurrences within a time period to trigger the alarm.
 - ⊙ **Number of Occurrences:** Specify the number of event occurrences.
 - ⊙ **Time Frame:** Select one of the time periods: **one hour**, **12 hours**, **one day**, **one week** or **one month**.

- Open the POS Table (**ViewLog > Toolbar > Tools > System Log**). The transactions met the defined alarm conditions will be marked with “unusual transaction” event in the System Log.



Time	Event	Content	Camera	coke	Golden Pl...	Total	Strawberry	Note
2/17/2017 17:10:57		Cash \$100.00	Camera...					
2/17/2017 17:11:01		Change \$87.63	Camera...					
2/17/2017 17:11:07		* Coke \$0.99	Camera...					
2/17/2017 17:11:11		* Apple Juice \$0.99	Camera...					
2/17/2017 17:11:15		* Papaya \$1.00	Camera...					
2/17/2017 17:11:19	Unusual transaction	* Strawberry \$5.99	Camera...				5.99	Incorrectprice
2/17/2017 17:11:23		* Peach \$3.99	Camera...					
2/17/2017 17:11:27		Reg 4889 5 Item	Camera...					
2/17/2017 17:11:31		Total \$12.96	Camera...			12.96		

Figure 10-7

10.4 Mapping Codepage

This feature is to support the display of special characters and symbols. When transaction text incorrectly appears on the screen, a wrong character code may be used. To change a character code, follow the steps below.

Note: When you cannot find a proper “Script” in the **Set Font** option (Figure 10-1), you may use the Codepage feature to fix the display issue of transaction text.

1. In the Device dialog box, select **Use Codepage Mapping** and select a character code from the drop-down list.

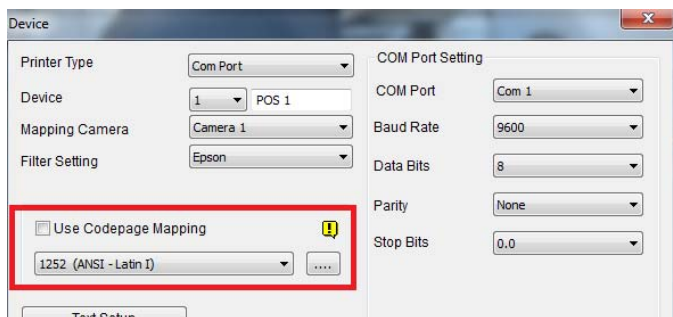

Figure 10-8

2. To verify the character code you selected, click the [...] button to preview its codepage.

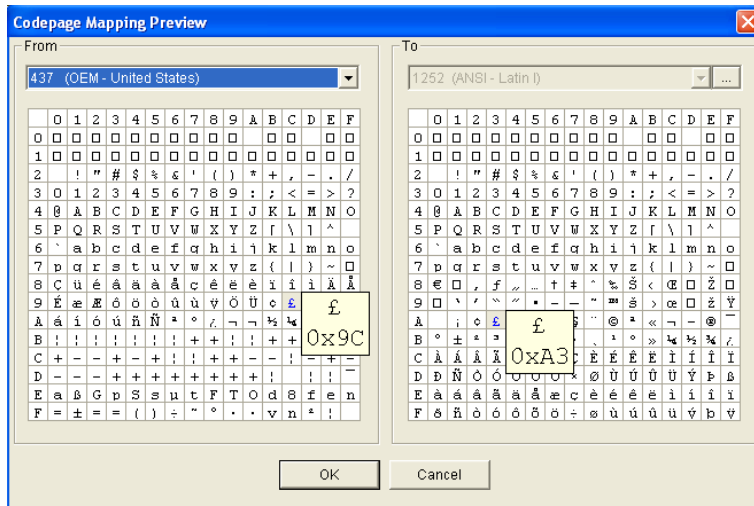

Figure 10-9

3. In the From field, select one symbol or character that are not displayed correctly. In this example, you can see its previous character code (From side: 0x9C) has been transferred to the default equivalent (To side: 0xA3).

10.5 Coloring Transactions of a Particular Item

You can highlight a desired transaction item in any color. When the transaction item is identified, its text will have an outstanding color than others on the live view, and the alarm and e-mail alerts can be triggered at the same time. For example, if the liquor is prohibited for sale in the midnight, a seller can use this feature to prevent from any unintentional sale.

The identification will be recorded in the System Log for later retrieval as well. In this example, the transaction item “Strawberry” is colored red, “Golden Pineapple” is orange, and “Ice Cream” is pink whenever these transaction items appear.

POS Table								
Time	Event	Content	Camera	coke	Golden Pi...	Total	Note	
2/16/2017 9:58:46		* Apple Juice \$0.99	Camera...					
2/16/2017 9:58:50		* Papaya \$1.00	Camera...					
2/16/2017 9:58:54		* Strawberry \$5.99	Camera...					
2/16/2017 9:58:58		* Peach \$3.99	Camera...					
2/16/2017 9:59:02		Reg 4889 5 Item	Camera...					
2/16/2017 9:59:06		Total \$12.96	Camera...			12.96		
2/16/2017 9:59:10		Cash \$20.00	Camera...					
2/16/2017 9:59:14	Cash Drawer o...	Change\$17.04	Camera...					
2/16/2017 9:59:19		* All Natural Creamline milk \$1.78	Camera...					
2/16/2017 9:59:23		* Golden Pineapple \$3.99	Camera...		3.99			
2/16/2017 9:59:27		* Ben Jerry Ice Cream \$3.00	Camera...					
2/16/2017 9:59:32		* Doritos Chips \$1.78	Camera...					
2/16/2017 9:59:36		Reg 4888 4 Item	Camera...					
2/16/2017 9:59:40		Total \$12.35	Camera...			12.35		
2/16/2017 9:59:44		Cash \$100.00	Camera...					

Figure 10-10

To configure the coloring feature, follow the steps below:

1. On the POS Server Setup dialog box, select **Capture Data Setting**. The POS Capture Data Setting dialog box appears.

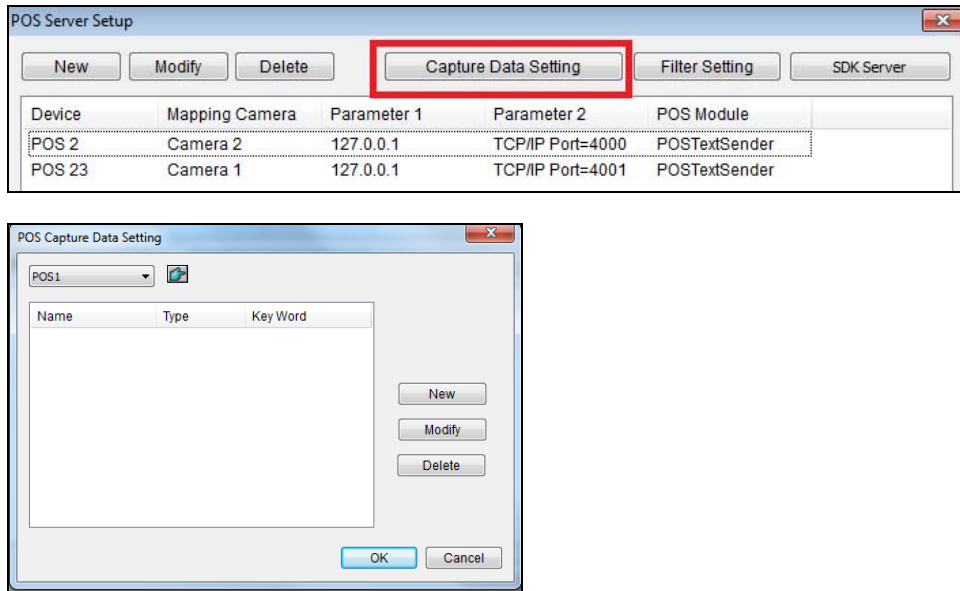

Figure 10-11

2. Click **New** and select **Color Keyword**. This dialog box appears.

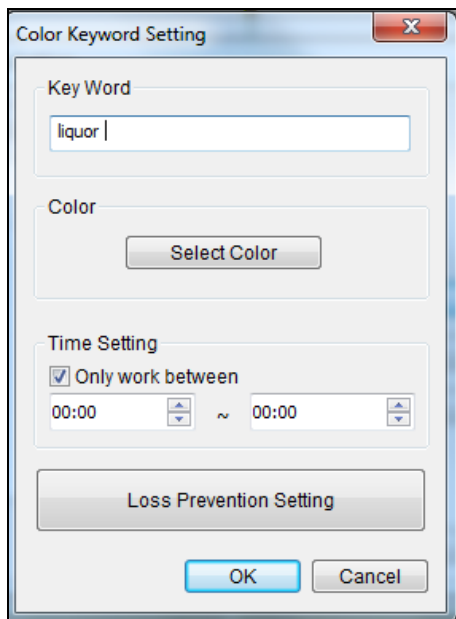

Figure 10-12

[Key Word] Type the keyword to be identified in the transactions. The field is case sensitive.

[Color] Select a color to show on the keyword.

[Only work between] Specify the time period of transactions to identify the keyword.

Note: You can set up to 32 keywords for identification.

3. To trigger an alarm when the keyword is detected during the transactions, click the **Loss Prevention Setting** button. This dialog box appears.

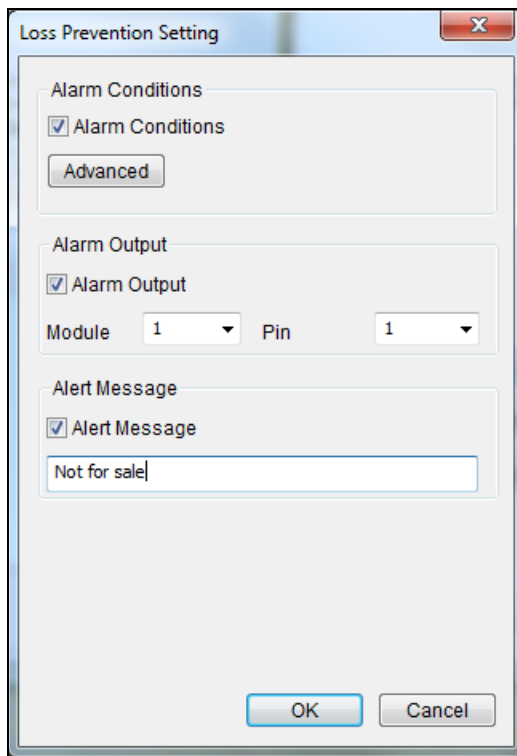

Figure 10-13

- **Alarm Conditions:** Enable the alarm when the defined text is detected. To configure alarm frequency, click the **Advanced** button. For details, see Step 3, *Triggering Transaction Alarms* earlier in this chapter.
 - **Alarm Output:** Assign an installed output module. When the defined alarm condition is met, the output alarm will be triggered.
 - **Alert Message:** Type an alert message. When the defined alarm condition is met, the e-mail alert will be sent. To enable e-mail notification, see *Setting up Email Notification* in Chapter 1.
4. Click **OK**.

When the keyword is identified in the transactions, the identification appears not only on the live view, but also are recorded in the System Log (**ViewLog > Toolbar > Tools > System Log > POS Table**).

10.6 Seeing the Receipt Details of a Particular Transaction

You can find out the receipt details of a single transaction. You will know the amount of the transaction, as well as the total number and total amount of all transactions during a defined period of time.

The screenshot displays the 'Advanced Log Browser' window for 'POS - 01'. The main window shows a table of transactions with columns for ID, Time, Event, Device, Content, Camera, Total, Note, and DST Rollback. A red box highlights the entire table with the text 'All the transaction contents related to the single transaction'. An inset window titled 'Transaction List' shows a detailed view of a single transaction at 2017/02/07 00:00:52, with a red arrow pointing to it and the text 'A single transaction'. Below the list, summary statistics are shown:

Transaction Count	Single Transaction Amount	Total Transaction Amount
1486	12.35	18805.25

Blue arrows point to these statistics with the following labels: 'Number of transactions during the defined period of time' (pointing to 1486), 'Amount of the single transaction' (pointing to 12.35), and 'Total amount of transactions during the defined period of time' (pointing to 18805.25).

Figure 10-14

To have the feature, you need to define the format of how the amount of a transaction is shown and how a transaction ends on the receipt. Follow the 3 steps below to complete the settings:

- Step 1: Defining the Amount of a Transaction Shown on the Receipt
- Step 2: Define How a Transaction Ends on the Receipt
- Step 3: Seeing the Receipt Details of a Transaction

Step1: Defining the Amount of a Transaction Shown on the Receipt

1. On the POS Server Setup dialog box, select a desired POS device, and select **Capture Data Setting**. The POS Capture Data Setting dialog box appears.
2. Click the **New** button. This dialog box appears.

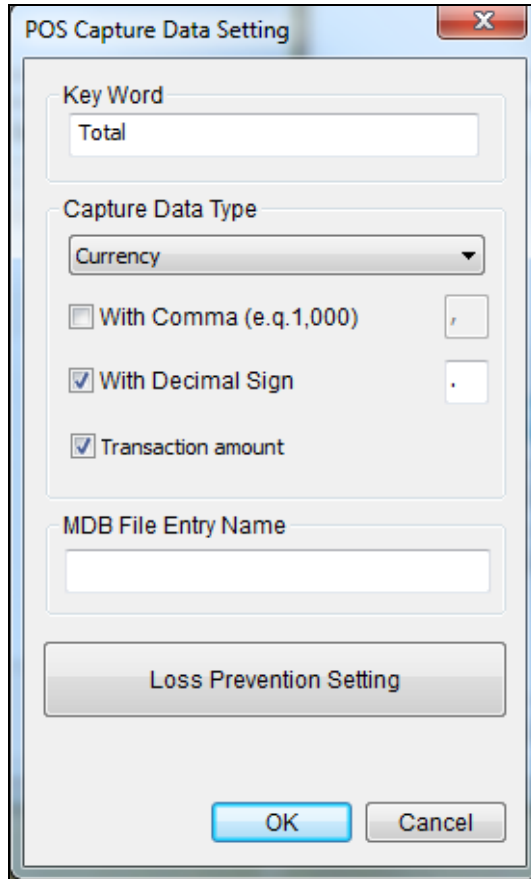

Figure 10-15

3. Take the following receipt as an example.

<p>* All Natural Creamline milk \$1.78 * Golden Pineapple \$3.99 * Ben Jerry Ice Cream \$3.00 * Doritos Chips \$1.78 Reg 4888 4 Item <u>Total \$12.35</u> Cash \$100.00 Change\$87.63</p>
--

Figure 10-16

- a. Type the **keyword** related to the amount of a transaction. In this example, the keyword is “**Total**” which is a prefix in the amount and appears in every receipt. Note the field is case sensitive.
 - b. Under Capture Data Type, define if the total amount is attached with a currency symbol. In this example, select **Currency** because the currency symbol \$ is used.
 - c. Select **With Comma** if there are commas in the total amount. Select **With Decimal Sign** if there are decimal signs in the total amount. In this example of “Total \$12.35”, select **With Decimal Sign**.
4. Select **Transaction Amount**, and click **OK**.

Step 2: Defining How a Transaction Ends on the Receipt

5. On the POS Server Setup dialog box, select the specific POS device, and select **Filter Setting**. The Filter Setting dialog box appears.

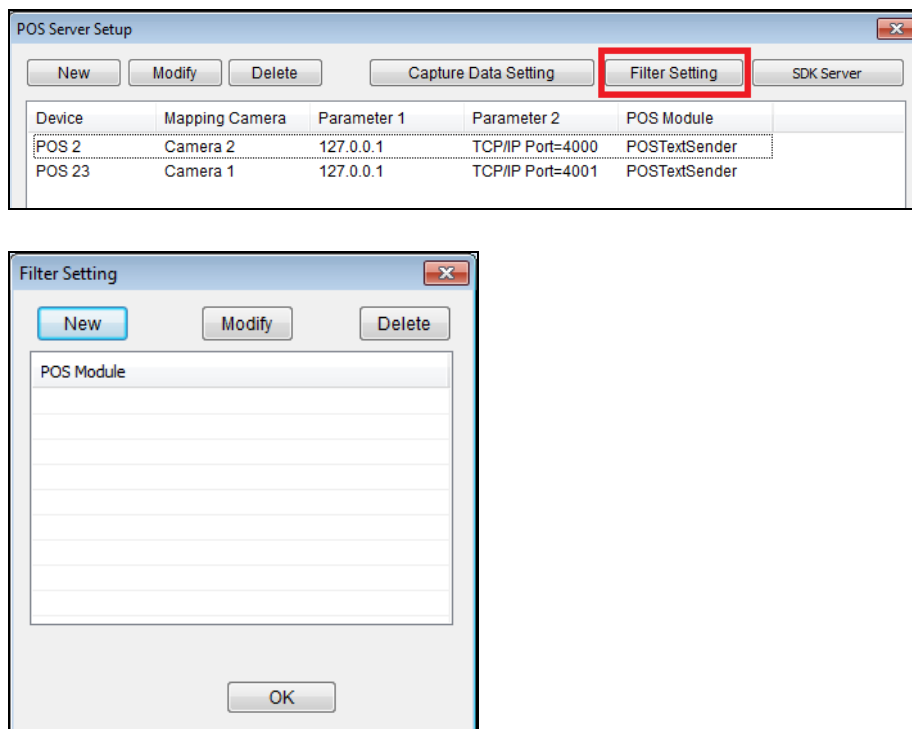

Figure 10-17

6. Click the **New** button. This dialog box appears.

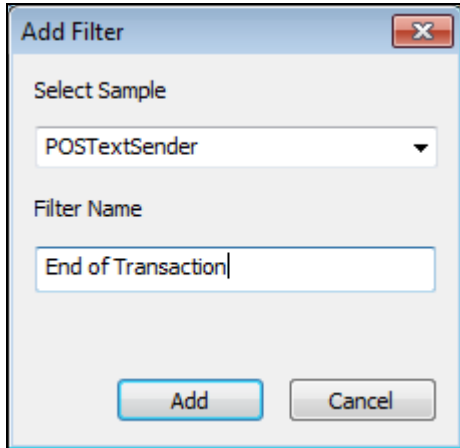

Figure 10-18

- a. Under Select Sample, select the type of printer attached to the POS device, or the GeoVision program installed in the POS device.
 - b. Under Filter Name, name the filtering criteria. In this example, we will define how a transaction ends on a receipt, so naming it as “End of Transaction”.
7. Click the **Add** button. The Filter Name appears in the list.
 8. Select the created filter name and click the **Modify** button. This dialog box appears.

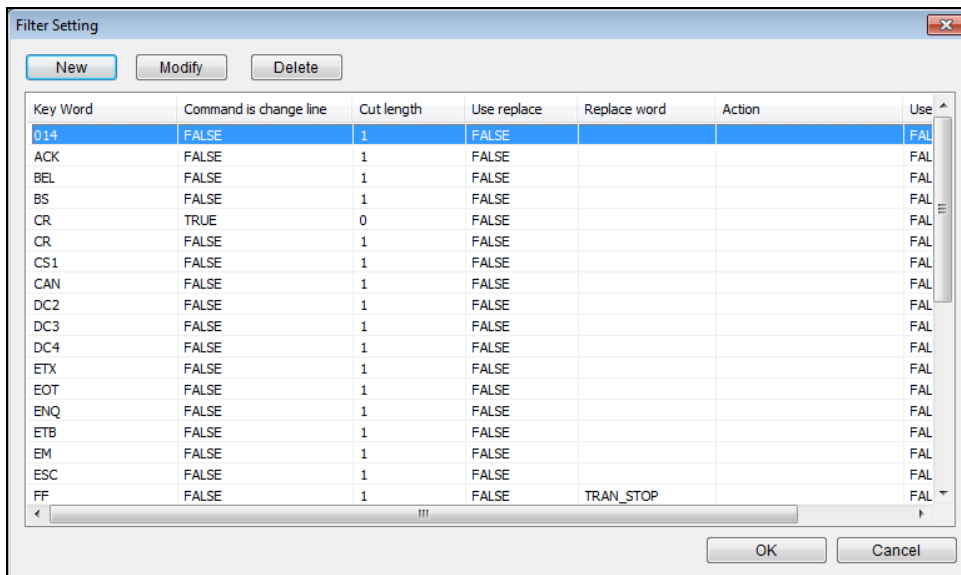

Figure 10-19

9. Click the **New** button. This dialog box appears.

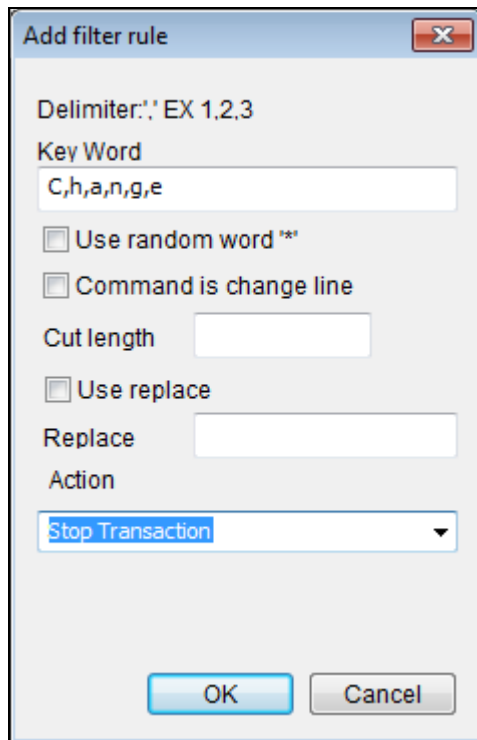

Figure 10-20

10. Type the **keyword** indicating the end of a transaction, and add comma (,) between every letter. In this example, the keyword is “Change” which appears at the end of every transaction, so type C,h,a,n,g,e.

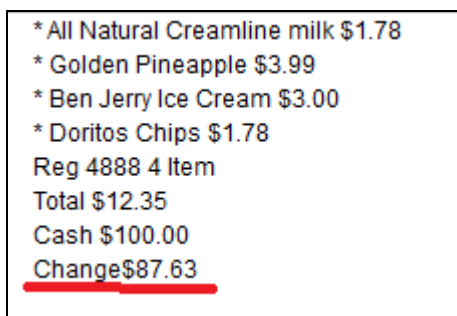

Figure 10-21

11. Under Action, select **Stop Transaction**.
12. Click **OK** several times to return to the POS Server Setup dialog box.

13. Select the POS device in the list applied for the filter setting, and click the **Modify** button. The Device dialog box appears.
14. Under Filter Setting, select the filter setting you set up for the end of a transaction. In this example, its "End of Transaction".

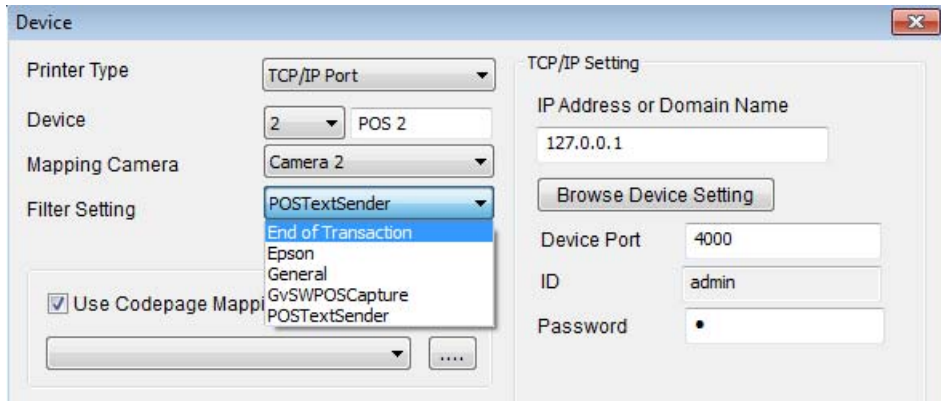

Figure 10-22

15. Click **OK**.

Step 3: Seeing the Receipt Details of a Transaction

16. Select **ViewLog** > **Toolbar** > **Tools** > **System Log** > **Advanced**. The Open Database dialog box appears.
17. Define a period of time to retrieve the POS data.
18. From the left side of toolbar, select **POS** data, select which **POS** device, and click to have a list of transactions during the defined period of time.

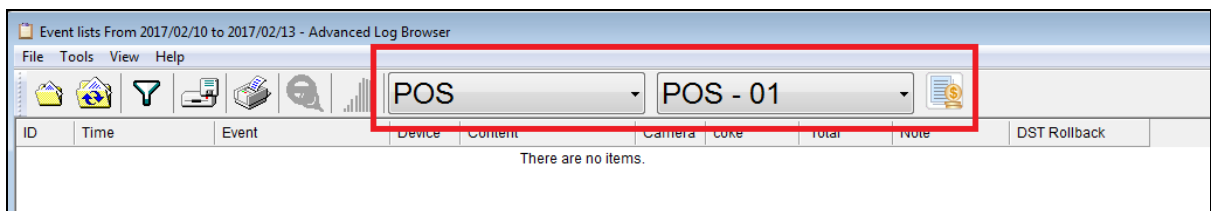

Figure 10-23

19. When you click a transaction on the List, its related receipt content will be displayed.

10.7 Filtering Transactions by a Keyword

You can filter transactions by a keyword to have the following functions: to start a new line after the keyword, to remove unwanted text before the keyword, to replace a keyword with another, and/or to be noted as Event, such as Cash Drawer Open, in the System Log when the keyword appears.

For example, we define “Change” as the keyword, and specify it as “Cash Drawer Open” event. Whenever “Change” appears on the receipt, in the System Log, you will see not only the details of the transaction, but also an event “Cash Drawer Open” recorded.

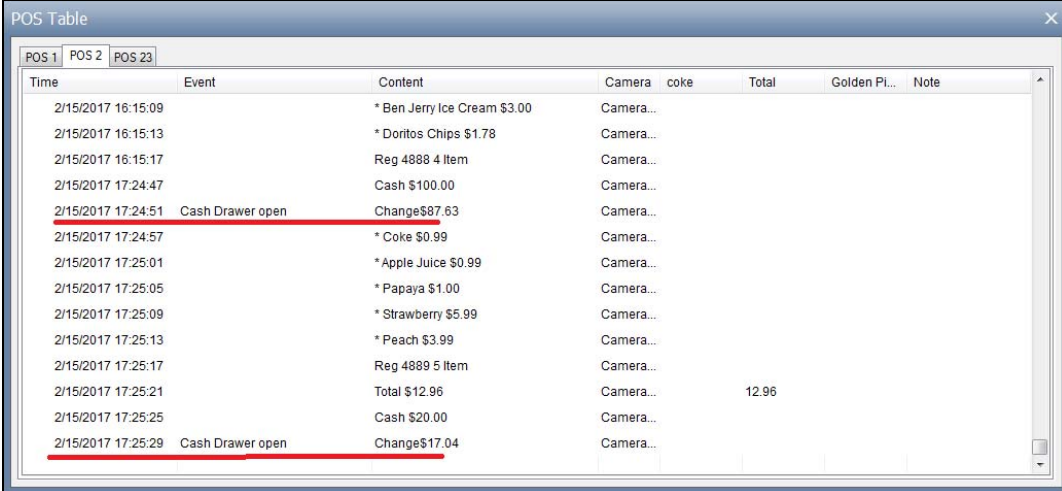

Time	Event	Content	Camera	coke	Total	Golden Pl...	Note
2/15/2017 16:15:09		* Ben Jerry Ice Cream \$3.00	Camera...				
2/15/2017 16:15:13		* Doritos Chips \$1.78	Camera...				
2/15/2017 16:15:17		Reg 4888 4 Item	Camera...				
2/15/2017 17:24:47		Cash \$100.00	Camera...				
2/15/2017 17:24:51	Cash Drawer open	Change\$87.63	Camera...				
2/15/2017 17:24:57		* Coke \$0.99	Camera...				
2/15/2017 17:25:01		* Apple Juice \$0.99	Camera...				
2/15/2017 17:25:05		* Papaya \$1.00	Camera...				
2/15/2017 17:25:09		* Strawberry \$5.99	Camera...				
2/15/2017 17:25:13		* Peach \$3.99	Camera...				
2/15/2017 17:25:17		Reg 4889 5 Item	Camera...				
2/15/2017 17:25:21		Total \$12.96	Camera...		12.96		
2/15/2017 17:25:25		Cash \$20.00	Camera...				
2/15/2017 17:25:29	Cash Drawer open	Change\$17.04	Camera...				

Figure 10-24

To configure the function, follow the steps below:

1. To open the following dialog box, follow Step 5 to 8 in *Step 2: Defining How a Transaction Ends on the Receipt*, 10.6 *Seeing the Receipt Details of a Particular Transaction*.

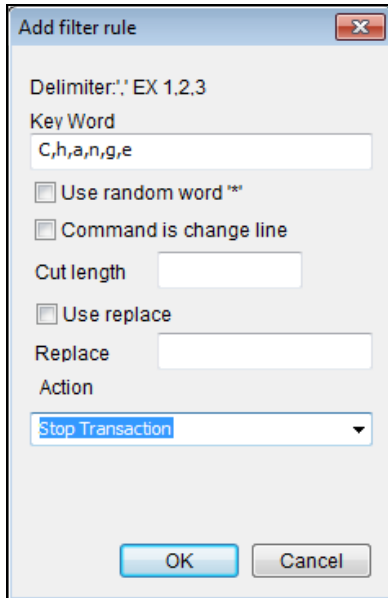

Figure 10-25

2. Type the **keyword** and add comma (,) between every letter. In this example, the keyword is “Change”, so type C,h,a,n,g,e.
3. If the keyword has a random prefix, select **Use Random Word**, and type the symbol (*) before the keyword, e.g. *,C,h,a,n,g,e.
4. If you want the text to start a new line whenever the keyword appears, select **Command is change line**.
5. If you want to remove garbled text before the keyword, type the number of characters you want to remove in **Cut Length**.
6. If you want to replace the keyword with another, select **Use Replace** and type a desired word.
7. You can define an event to show on the System Log: Alert, Cash Drawer Open, Cash Drawer Close, Start Transaction, Stop Transaction, or Valid Transaction.
8. Click **OK** several times to return to the POS Server Setup dialog box.

9. Select the POS device in the list applied for the filter setting, and click the **Modify** button. The Device dialog box appears.
10. Under Filter Setting, select the filter setting you set up before. In this example, it is Cash Drawer Open.

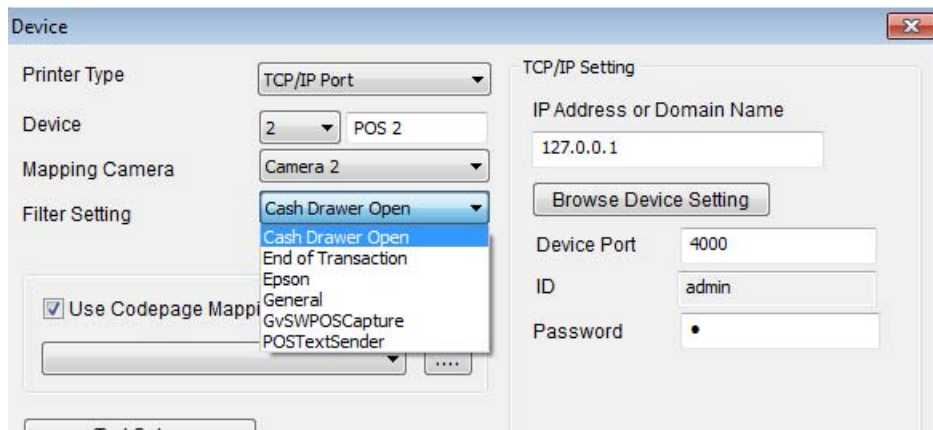

Figure 10-26

11. Click **OK**.
12. Open the System Log (**ViewLog > Toolbar > Tools > System Log > POS Table**) to view the filtering results.

10.8 Searching for and Playing back POS Events

Only available on GV-VMS V18.1 or later, with the POS Search function, users can instantly search for and play back the recordings of POS events from the ViewLog. To access this function, click **ViewLog** > **Toolbar** > **Tools** > **POS Search**. This window appears.

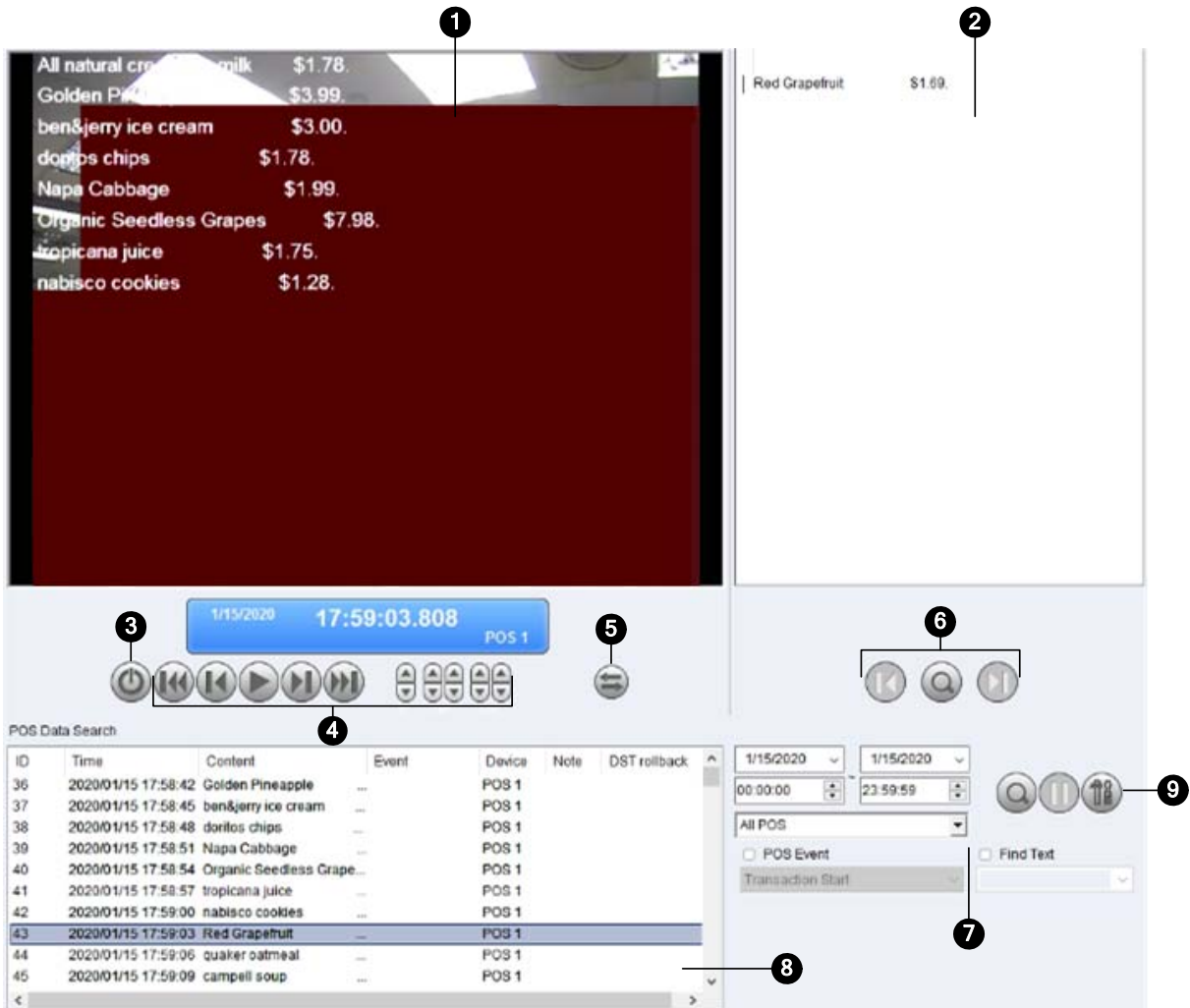







Figure 10-27

No.	Name	Description
1	Playback Window	Displays the recording of the POS event or content selected. Right-click on the window to have the options of Play Mode , Render and Tools
2	Transaction Window	Displays all POS transactions viewed while playing back on the Playback Window.
3	Exit	Click to close Quick Search screen
4	Playback Panel	Includes Play, Pause, Previous 10 frames, Next 10 frames and End buttons, as well as Time Period buttons to jump to 1 second, 10 seconds, 1 minute, 10 minutes and/or 1 hour later or earlier.

5	Expand / Shrink Dialog	Select Expand/Shrink Dialog to display the Transaction window or select Advanced Search to display the Advanced Search panel.
6	Find Condition	Click Find Condition  to search for specific keywords and/or a type of POS transaction event forward or backward, starting from a date and time set. Use the Find Previous  and Find Next  buttons to jump from one search result to another.
7	Advanced Search Panel	See <i>6.1.1 Advanced Search Settings</i> later.
8	Search Results	Displays the search results by Advanced Search.
9	320<->640	Click to switch between 640 x 480 and 320 x 240 display.

Advanced Search Panel

To search for POS events with detailed criteria, click **Expand / Shrink Dialog**  on the POS Search window and select **Advanced Search**. The Advanced Search Panel appears.

1. Select the **Start / End Dates** and **Start / End Times** from the respective drop-down lists to specify the desired time period of your POS search.
2. Select the POS devices you want to search for in the **POS Device** drop-down list.
3. Optionally select **POS Event** to search for a type POS transaction event.
4. Optionally select **Find Text** to type a keyword you want to search for.
5. After the desired conditions are set, click **Search** . The search results will be displayed at the left of the panel.